

01/2024

VM VERLAG  
Cologne /Germany

# EXTRUSION INTERNATIONAL



# Guill

WORLD LEADER IN EXTRUSION TOOLING

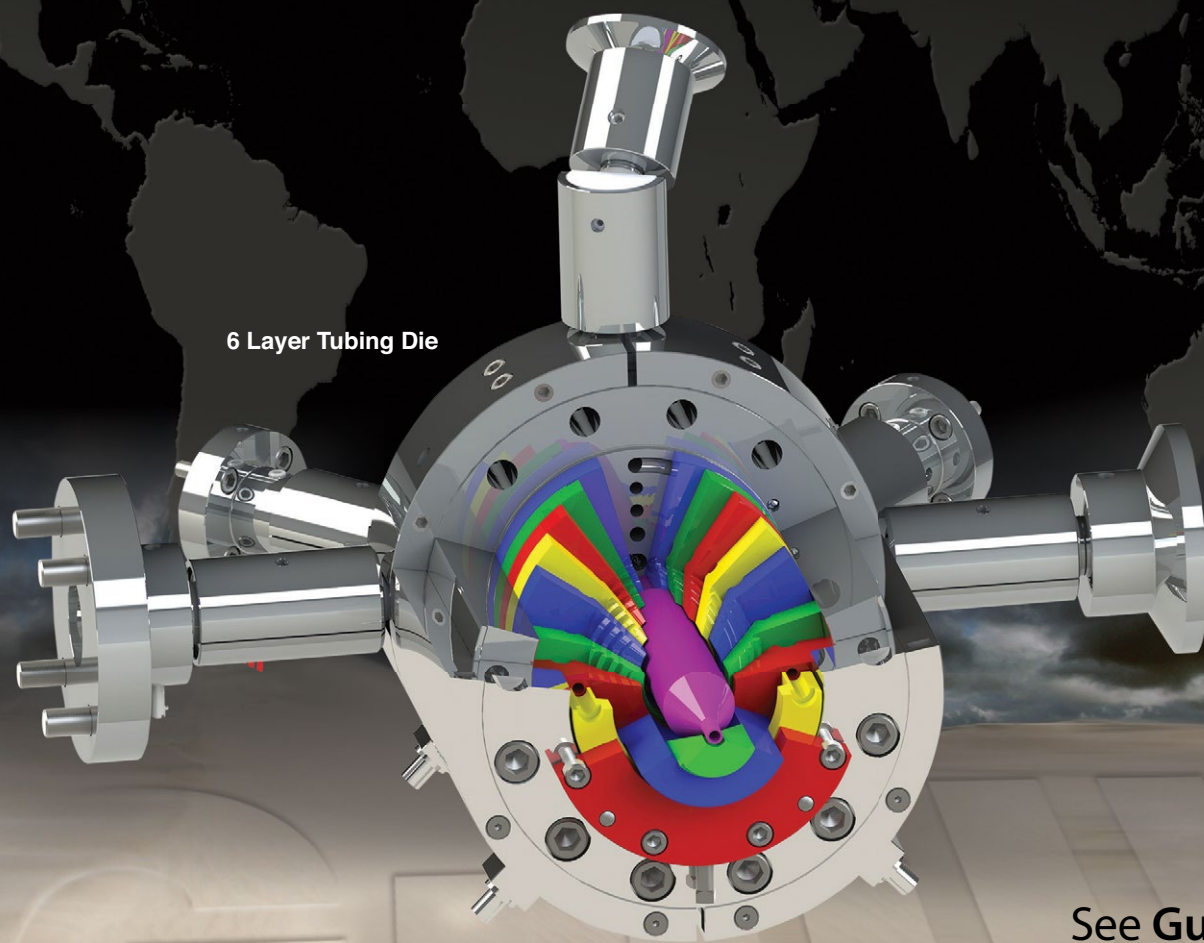

6 Layer Tubing Die

[www.guill.com](http://www.guill.com)

See Guill at  
**NPE 2024**  
The Plastics Show  
Booth W7051

## Stein Profile Stacker

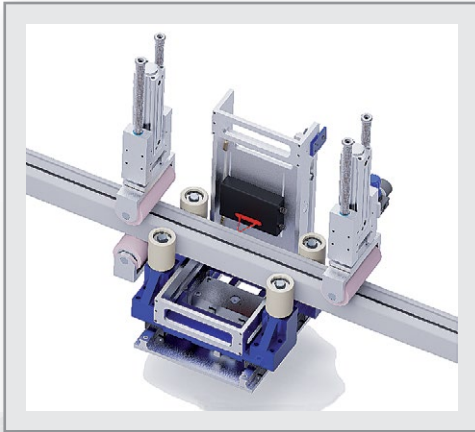

### Profile length measurement during extrusion

Measuring sensors are used to determine the length of individual profiles before a profile layer is formed.

The measured length can be used to check and correct the cutting device of the extrusion line or for documentation (quality assurance) of the produced profile lengths.

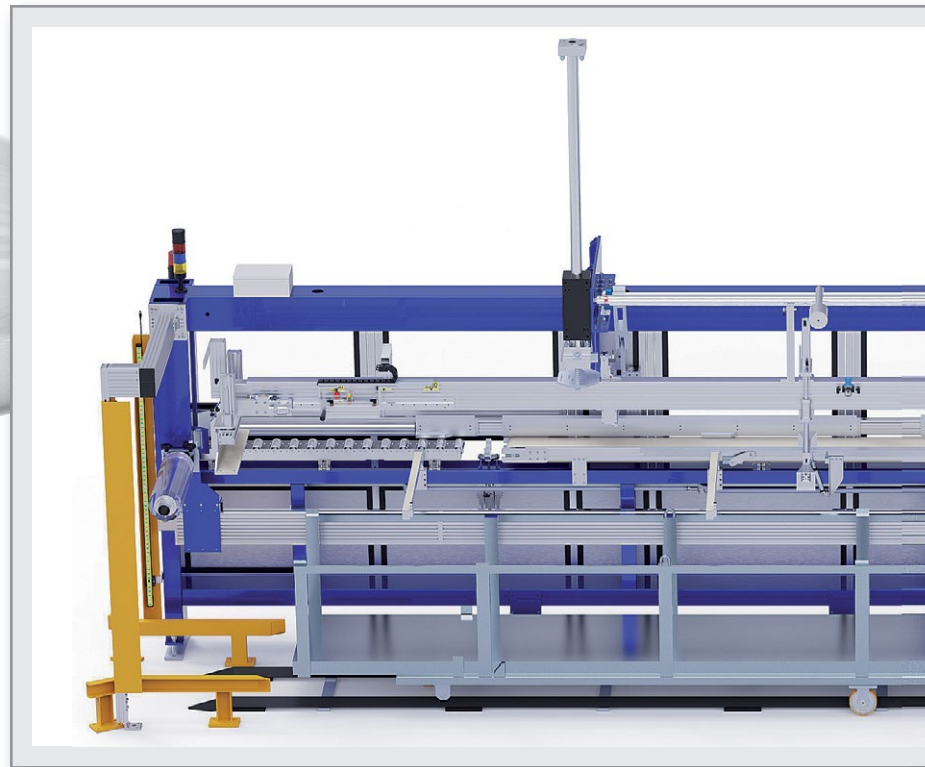
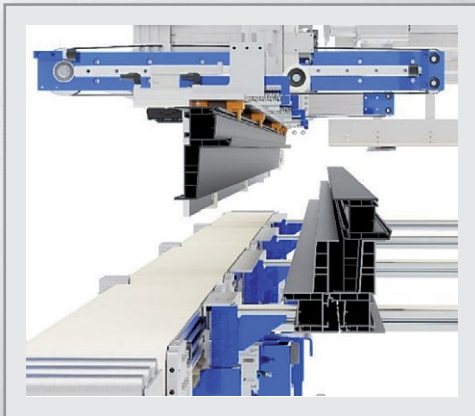

### Stacking of special profiles

Stein Maschinenbau offers technical solutions for stacking of heavy and large monoblock profiles.

Based on decades of experience, we can unusual profile geometries or special layer can be evaluated for their automated stacking.

### Cassette spreader

With the help of a cassette spreader it is possible to realise the same packing density of the manual packaging.



## Stein Profile Stacker



### Weight determination during extrusion

With the help of special weighing units, individual profiles can be weighed before a profile layer is formed. The determined weight can be used to optimise the extrusion.

As a specialist in the field of special machine construction, we always find a solution!

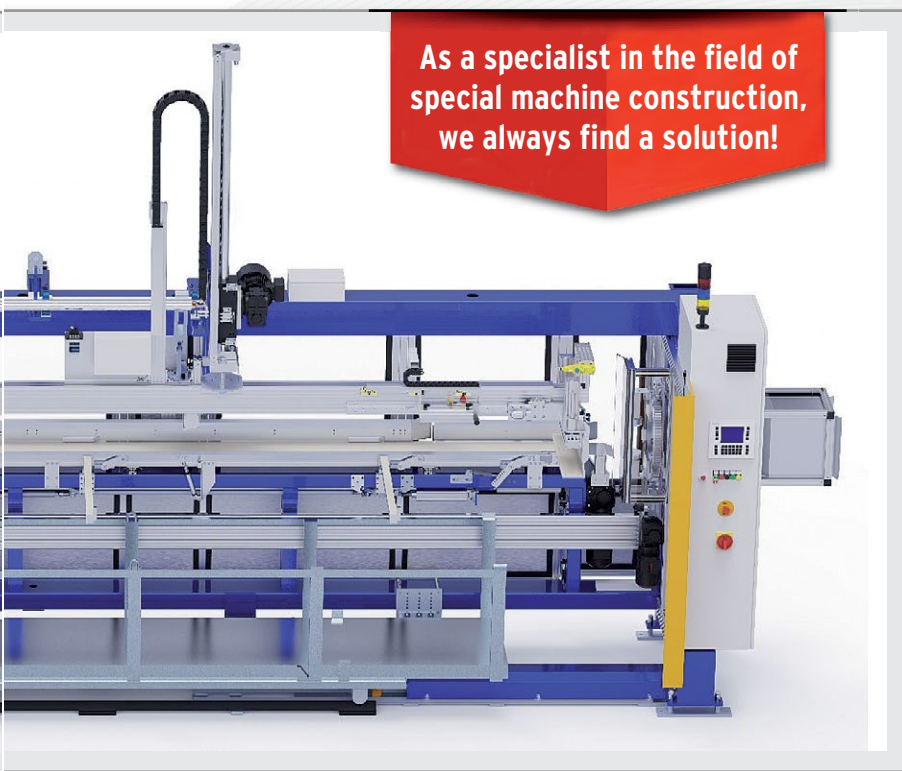

### Cassette handling

The handling system allows empty cassettes to be fed into the automatic stacker and the filled cassettes to be pushed out.

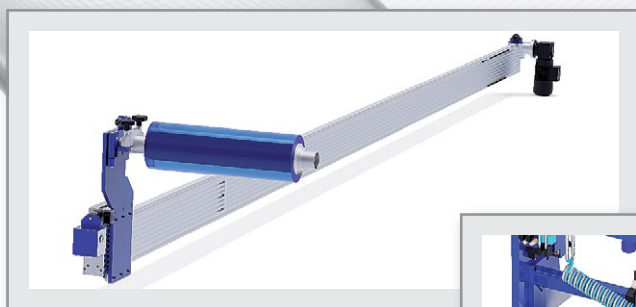

### Profile interlayer

Endlessly laid as a foil between the profile layers or with individual strips laid on the layer.

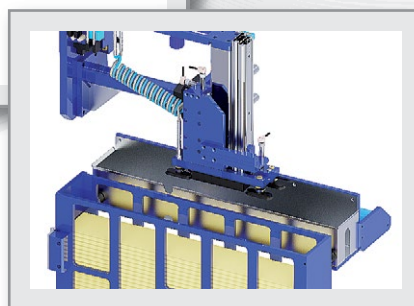

**STEIN Maschinenbau  
GmbH & Co. KG**

Wartbachstrasse 9  
66999 Hinterweidenthal/Germany  
Tel. (+49) (0)63 96-9215-0  
Fax (+49) (0)63 96-9215-25  
stein@stein-maschinenbau.de  
www.stein-maschinenbau.de

## CONTENTS

Firms in this issue	6	Acquisition	22
Imprint	7	Focus on Recycling	23
<b>Industry News</b>	8	<b>CHINAPLAS 2024</b>	
Calendar	8	Plastics Industry Players to Boost Intelligentization, Lightweighting, and Decarbonization of New Energy Vehicle	24
Plastpol 2024 – New Technologies, New Contacts, New Supply Chains	8		
K 2025 – Messe Düsseldorf Invites Exhibitors	9	<b>Extrusion Tooling</b>	
Future Dates for NPE:		Extrusion Takes Some New Turns	27
The Plastics Show Announced	9	<b>Recycling</b>	
Acquisition	10	New Filtration Compounder for Higher Product Quality and Reduced Energy Consumption in PCR and Polymer Recycling	29
New Investor	10		
Swop 2023 Successfully Concludes and Paves the Way for Annual Edition	12	<b>Recycling – Case Study</b>	
Success Stories from Cairo – Food Africa and pacrprocess MEA 2023 End with a New Record	13	100 Metric Tons of PET Recyclate Per Day – Fifth PET Washing Line to Türkiye	30
Encouraging Preliminary Results	13	<b>Film Extrusion</b>	
Circular Economy in India on Track for Growth	14	Latest Version of Multi-Purpose Cast Film Line with New MDO Unit	31
Top Employer in the Medium-Sized Business Sector	15	<b>Blow Molding</b>	
Four Carbon Black Plants Awarded ISCC Plus Expansion with Additional Services in Malaysia	16	PET Bottle Design for Highly Carbonated Drinks	32
Setting the Course for the Future	16	<b>Recycling</b>	
Management Change	17	New INNOSORT™ FLAKE for Unrivaled Flame Sorting Performance	34
Personalia	17	<b>Processing – Interview</b>	
Team with Design Engineers Expanded	18	Pellet Vision – Constant Pellet Quality – Forever!	36
Increased Presence in Eastern Europe	18	<b>Measurement and Inspection</b>	
Personalia	19	<b>Technology for Profiles</b>	
Personalia	19	Going with the Trend – Shiny Detection Module Excels in Inspecting Vehicle Trims in Chrome and Trendy Black	38
Support from Europe for Trade Fair	20	<b>Measurement Technology</b>	
Plástico Brasil	20	Inline Thickness Measurement as a Success Factor in Plastic Film and Sheet Extrusion	40
„Premium Partner Research“ Award Received	20		
Investment in Global Service Capabilities to Bolster Customer Service and Support	21		
Distribution Partnership in Italy Signed	21		
Pure Material, Best Quality – 10 Years PURITY SCANNER	22		
ADVANCED	22		

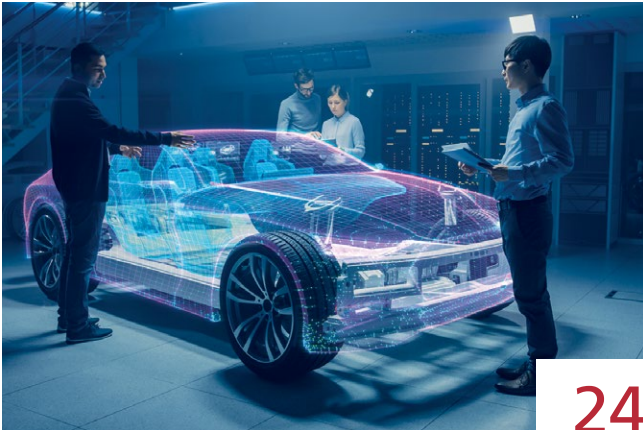

24

CHINAPLAS 2024 is set to make a strong comeback to Shanghai on April 23 to 26, 2024, and will bring together the latest solutions in intelligent transportation, energy efficiency, environmental health, and other technological and process applications in the fairground



30

The first truck has left the yard. Another 20 will follow. They will deliver the newest washing line from Herbold Meckesheim to Kırklareli, Türkiye. There, in the European part of Türkiye, the latest recycling plant of the Meckesheim-based special machinery manufacturer is being built for the company Doğa



31

SML has set up the newest version of its multi-purpose cast film line in its Technology Centre. The line is universally applicable and features a number of technical innovations: Above all, a further-developed MDO unit



32

Cherkasy Brewery Company (Ukraine), a producer of beer and soft drinks, has modernized its fleet of equipment to produce PET bottles and purchased a blow molding machine manufactured by PET Technologies. It is integrated into a complete filling line

The new Shiny Detection inline module from PIXARGUS is a perfect solution to detecting scratches and bubbles on the challenging high-gloss surfaces of vehicle trims. A Canadian automotive supplier has been using the PIXARGUS technology for many years



38



40

SBI Mechatronik and its global distribution network, covers various areas with its comprehensive range of measurement technologies, including sheet for thermoforming applications, conductive and foamed films and sheets, cast and stretch films, as well as EVA films for solar panels and coating applications

## Index of Advertisers, companies and fairs referred in this issue

Adsale	Outside Back Cover, 24	MAAG	16
ALPLA	23	Messe Düsseldorf	9
AMAPLAST	13	motan	7
ARJ Auxiliary Equipment	40	NGR	17
Borealis	19, 22	NPE2024	9
CHINAPLAS	Outside Back Cover, 24	Orion	16
CITEX	10	pacprocess MEA	13
ColVisTec	20	PET Technologies	32
Coperion	29	Pixargus	9, 10, 38
Davis-Standard	21	Plastpol	8
ECON	36	SBI Mechatronik	40
Erge	19	Sikora	14, 22
EUROMAP	20	Smart-Extusion	Inside Back Cover
European Bioplastics	19	SKZ	16, 20, 21
Food Africa	13	SML	23, 31
Guill Tool & Engineering	Outside Cover, 18, 27	Stein Maschinenbau	Inside Front Cover+3
Hellweg Maschinenbau	18	Swop	12
Herbold Meckesheim	30	Targi Kielce	8
iNOEX	10	TOMRA	34
Jwell	10	VM Verlag	Inside Back Cover
K 2025	9	Zumbach	15
Kautex	10		
Koch Technik	11		
KraussMaffei	17		



## Follow the news in the world of extrusion!

Subscribe to digital magazines  
and Smart Extrusion weekly newsletter

- **Just** submit your **e-mail address**.
- Digital magazines and news updates **free of charge**
- No spam. Your data is safe



[www.extrusion-info.com/subscription](http://www.extrusion-info.com/subscription)

01/2024

VM VERLAG  
Cologne / Germany

# EXTRUSION INTERNATIONAL



The Extrusion International Magazine is published bimonthly by VM Verlag GmbH. P.O.Box 501812, D- 50879 Cologne, Germany

#### EDITOR

Bettina Jopp-Witt (Editor-in-chief)  
Tel. +49 221 546 1539  
redaktion@vm-verlag.com

#### ADVERTISING SALES

Martina Lerner  
Tel.+49 6226 971515  
lerner-media@t-online.de

Bella Eidlin  
Tel. +49 152 29907895  
b.eidlin@vm-verlag.com

Tanja Bolta  
t.bolta@vm-verlag.com  
+49 15205626122

#### ADMINISTRATION

Alla Kravets  
Tel. +49 2233 949 8793  
a.kravets@vm-verlag.com

#### PRINTING

maincontor GmbH  
Dr.-Gammert-Str. 13a,  
63906 Erlenbach, Germany  
T.: +49 937294810811  
www.maincontor.de,  
info@frankhohmann.com

#### SALES REPRESENTATIVES

China & Asia  
octavia@ringier.com.hk,  
Tel. +852-9648-2561  
maggieliu@ringiertrade.com,  
Tel. +86-13602785446

Tokyo PR Inc. (Japan)  
Tel. +81 (3) 3273-2731  
extrusion@tokyopr.co.jp

#### Reprints, Translation etc

No part of this publication may be reproduced, stored in a retrieval system, or transmitted, in any form or by any means, electronic, mechanical, photographic, recording or otherwise, without prior permission of the publisher.

[www.smart-extrusion.com](http://www.smart-extrusion.com)



motan

## MOISTURE MINDER™

### Online & Inline moisture sensor

Efficient, accurate material drying is a crucial element in the processing of engineering plastics to ensure impeccable product quality. Up to now, there has been no reliable way to continuously monitor and control that material coming out of a drying bin is dry.

The MOISTURE MINDER™ system can continuously, efficiently and accurately measure the residual moisture content of plastic granules with material throughputs from 10 to 2500 kg/h. The sensor can be mounted directly under the drying bin and accurately displays the actual moisture content of plastic granules, in % or ppm (parts per million).



ZERO LOSS

[www.motan.com](http://www.motan.com)



**13th European Thermoforming Conference**  
11 - 12 April 2024  
Amsterdam / The Netherlands  
[www.thermoforming-europe.org](http://www.thermoforming-europe.org)

**wire and Tube**  
15 - 19 April 2024  
Düsseldorf / Germany  
[www.wire.de](http://www.wire.de), [www.tube.de](http://www.tube.de)

**Chinaplas 2024**  
23 - 26 April 2024  
Shanghai / PR China  
[www.ChinaplasOnline.com](http://www.ChinaplasOnline.com)

**NPE2024**  
06 - 10 May 2024  
Orlando, Florida / U.S.A.  
<https://npe.org/>

**KUTENO**  
14 - 16 May 2024  
Rheda-Wiedenbrück / Germany  
[www.kuteno.de](http://www.kuteno.de)

**Plastpol**  
21 - 23 May 2024  
Kielce / Poland  
[www.targikielce.pl/en/plastpol](http://www.targikielce.pl/en/plastpol)

**Fachpack**  
24 - 26 September 2024  
Nuremberg / Germany  
[www.fachpack.de](http://www.fachpack.de)

**Solids Dortmund**  
09 - 10 October 2024  
Dortmund / Germany  
[www.solids-dortmund.de](http://www.solids-dortmund.de)

**Fakuma 2024**  
15 - 19 October 2024  
Friedrichshafen / Germany  
[www.fakuma-messe.de](http://www.fakuma-messe.de)

**ICE Europe 2025**  
11 - 13 March 2025  
Munich / Germany  
[www.ice-x.com](http://www.ice-x.com)



## Plastpol 2024 – New Technologies, New Contacts, New Supply Chains

■ The world of advanced plastics processing technologies, innovative injection moulding and extrusion machines, and modern polymer materials; this and much more will be at Targi Kielce's (Poland) for a four-day show in May 2024. Plastpol welcomes the most important industry companies from Europe and Asia; they all come to Kielce to present their latest offers. The organisers say that the expo space availability is now limited.

“According to all indicators, the International Fair of Plastics and Rubber Processing PLASTPOL will again reassure its position of Central and Eastern Europe's largest event for plastics processing industry. For the 28th time, Targi Kielce brings together key companies. The majority of our exhibitors with whom we have been cooperating for years have confirmed their presence. There are also many first-time exhibitors; they appreciate the power of the Plastpol in Poland. Companies from many European and Asian countries, including those from India, China, the Republic of Korea, and Turkey join the expo. National expo stands are held by Germany, the Czech Republic and Portugal,” says Kamil Perz, director of the Plastpol project at Targi Kielce. “We already know that exhibitors will occupy the entire space of our exhibition and congress centre; we are open for the last registrations. There are not many spots available to choose from.”

Remember that the last Kielce plastics processing expo in May 2023

hosted 600 companies from 29 countries and their extensive offer. About half of the exhibitors are foreign companies representing Austria, Belgium, the Czech Republic, Denmark, Egypt, France, Spain, the Netherlands, India, Ireland, Israel, Japan, South Korea, Turkey, Italy, Germany, Portugal, Romania, Switzerland, Sweden, Slovakia, Taiwan, Ukraine, UK, Hungary, Latvia and China.

### Industry conferences and the Omniplast competition

The new technologies exhibition is accompanied by conferences. “Meetings with experts and lectures offered by industry specialists are appreciated by our exhibitors and visitors. Such sessions serve their purpose - discussion, setting course of actions and new goals,” emphasises Agnieszka Dąbrowska, deputy director of the Plastpol project at Targi Kielce.

Omniplast competition for experts in the plastics and rubber processing industry is an essential element of the show – OMNIPLAST aims to disseminate and popularise knowledge of plastic processing and the related processing technologies. Representatives of companies exhibiting at the Plastpol can take part in the contest; the winners are in for really attractive prizes.

This year's expo is held from 21 to 24 May 2024.

➔ <https://www.targikielce.pl/plastpol>



## K 2025 – Messe Düsseldorf Invites Exhibitors

■ “It’s K time again” – for all the companies intending to participate in K 2025 in Düsseldorf. From 8 to 15 October 2025 the international plastics and rubber industry will again meet at its most important international trade fair. Registration documents are now available. For all companies wishing to take part in K 2025, the deadline for registrations is 31 May 2024.



The ranges on display at this the leading trade fair comprise the segments machinery and equipment, raw materials and auxiliaries as well as semi-finished products, technical parts and reinforced plastic products. What’s more: K 2025 is not only the industry’s performance barometer and its global marketplace for innovations but also provides orientation, sets sustainable economic impulses and present forward-looking trends.

K 2025 in Düsseldorf addresses the mega themes climate protection, digitalisation and circular economy. K 2022 already succeeded in making a powerful statement in these fields presenting sustainable solutions that will be taken to the next level in 2025. Exhibitors at the forthcoming K will showcase further innovations for the responsible and value-driven handling of plastics and rubber as well as flag up new avenues that allow plastics to be managed in closed-loop systems.

## Future Dates for NPE: The Plastics Show Announced

■ The Plastics Industry Association (PLASTICS) gears up to host its triennial show on May 6-10, 2024, encourages attendees to start planning for 2027 and beyond. NPE2027, NPE2030 and NPE2033 will all be held in May of their respective years at the Orange County Convention Center (OCCC) in Orlando, Florida.

PLASTICS invites NPE2024 attendees and those who plan to attend in the future to save the following dates for upcoming shows:

- NPE2027: May 3 – 7, 2027
- NPE2030: May 6 – 10, 2030
- NPE2033: May 2 – 6, 2033

“As we look forward and prepare for NPE2024, we want our members, exhibitors, attendees and stakeholders to know that we’re committed to planning for the future of this show and an exceptional quality experience,” said PLASTICS’ Senior Director of Trade Show Operations, Maureen Cudahy Cameron. “The industry’s future is bright, and we’re looking forward to hosting more bold leaders, creative thinkers, and visionaries from every industry in the world at future NPE shows for years to come.”

NPE2024, the most anticipated plastics exposition in the Americas, will open on Wednesday, May 6, 2024, at the Orange County Convention Center with 2,000+ exhibiting companies and more than 55,000 expected attendees from all sectors of the global supply chain. For more information:

► [NPE.org](http://NPE.org)

The USPs of K in Düsseldorf include not only its extensive line-up of ranges exhibited by companies from all over the world but also the quality and variety of its side events including – in addition to the official Special organised by Plastics Europe and Messe Düsseldorf – the Specials Rubber Street, Science Campus and the Start-up Zone.

Registration documents for K 2025 can be downloaded at: [www.k-online.com/2330](http://www.k-online.com/2330).

Companies that already exhibited in 2022 can log in and register using their previous access data. First-time exhibitors are guided through the registration process step by step.

Messe Düsseldorf  
► [www.k-online.de](http://www.k-online.de)

**PIXARGUS**

**IN SPECT MORE**

**Surface. Geometry. All-In-One.**

**Inline Quality Inspection of Extruded Products**

**NPE2024** | May 6-10, 2024 | **VISIT US: W6792 in**  
The Plastics Show | Orlando, Florida | **West Building Level 2**

[www.pixargus.com](http://www.pixargus.com)

10176 International Boulevard, Cincinnati, OH 45246 (USA)

## Acquisition

■ CiTEX Holding GmbH announced the acquisition of PIXARGUS, based in Würselen, Germany. The technically specialised company has been offering inline quality control for extrusion products for 20 years, using unique image processing technology to detect and document flaws and material changes as part of automated surface inspection and geometry measurement of profiles, hoses, pipes, cables, and sheets made of plastic, metal, paper, and fibre composites, primarily for medium-sized customers in Europe. The acquisition underlines CiTEX Holding's commitment to consolidating its position as a leading provider of sensor and measurement technology and advanced digitalisation solutions worldwide, through its subsidiary iNOEX, and to distinguishing itself as a leading provider in the global plastics extrusion market.

"We are delighted to be able to utilise the expertise of PIXARGUS for our global customers, particularly with regard to the growth potential in the USA, China and Asia. Thanks to PIXARGUS' specialist competence, it will be possible for our group of companies to comprehensively address our global customer base in extrusion tech-

nology in the future. In addition, the acquisition will not only enable us to increase our market share in our key markets, but we will also be able to draw on a wealth of data and knowledge as part of our data science activities," says Dr. Ralph Klose, CO-CEO of CiTEX Holding GmbH. "PIXARGUS has profound knowledge of product development and consulting, particularly in the automotive and profiles market segments. Together, we will be able to provide our customers with comprehensive support across the entire automation cycle in the future."

"The business development of the CiTEX Group over the last four decades reflects the esteem in which it is held by both customers and suppliers in the field of sensor/measurement technology and also in the more advanced segment of data processing in extrusion technology. The comprehensive expertise that CiTEX subsidiary iNOEX brings to the SME sector is a significant asset for PIXARGUS and its activities. Our joint focus on promoting digital transformation using cloud solutions makes us a comprehensive solution provider in this market segment. The merger of the two companies also strengthens our planned global expansion."



Dr. Ralph Klose  
(CO-CEO CiTEX Holding GmbH)

"We are all looking forward to embarking on this journey together with our new colleagues in the CiTEX Group," emphasise Managing Directors René Beaujean and Dr. Jürgen Philipps of PIXARGUS.

CiTEX Holding GmbH  
➔ [www.citex-group.de](http://www.citex-group.de)

iNOEX GmbH  
➔ [www.inoex.de](http://www.inoex.de)

PIXARGUS GmbH  
➔ [www.pixargus.de](http://www.pixargus.de)

## New Investor

■ All Kautex Maschinenbau GmbH and related entities have been sold to Jwell, except the Kautex Shunde entity, on which a deal is within eyesight. All material assets and the entire business operations of the mechanical engineering company have been transferred to the Chinese investor. On January 1st, 2024, the new company – Kautex Maschinenbau System GmbH – took over all duties of the old company.

"With Jwell as new strong partner aside from Kautex Maschinenbau System GmbH, we have a bright future ahead. Jwell is a strategic fit for us. They have a strong background in plastics machinery manufacturing. They have the financial capabilities to complete Kautex transformation and they are committed to even increase our local manufacturing and service footprint with the target of creating the world market leader within the extrusion blow molding business", states Thomas Hartkämper, CEO of the Kautex Group.





Jwell took over 50% of employees of Kautex Maschinenbau GmbH in Bonn, 100% of employees in the other entities, and intends to keep on focusing on manufacturing production solutions at the Bonn site, which remains the headquarter with focus on manufacturing, R&D and service. Also, Kautex Maschinenbau GmbH in Bonn will be the third oversea production base of Jwell.

For those employees, not being transferred to the new company a transfer company was installed to further qualify them for new external job opportunities. This opportunity was well received and 95% of employees took this chance to make progress in their professional careers.

Kautex remains an independent operation within the Jwell Group and is intended to be its Premium Brand. With the transfer into a new company and the right-sizing of the staff base, first adjustments within the management have already been executed. Julia Keller, former CFO and CHRO of Kautex left the company and was replaced by Jun Lei as CFO. Maurice Mielke, until end of December 2023 Global Director R&D at Kautex was promoted to CTO and CHRO. Paulo Gomes, former CTO of the Kautex Group decided to leave the company, effective on February 1st.

Mr. He, president of Jwell, expressed this highest appreciation for all employees for the focused and dedicated work over last month and making this deal possible. He stated that together we can realize a dream of many years, to operate an entity enterprise in Germany, and to lead Jwell to become one of the world leaders in the high-end extrusion machinery industry.

Kautex Maschinenbau GmbH  
www.kautex-group.com

Jwell Machinery Co. Ltd  
www.jwell.cn

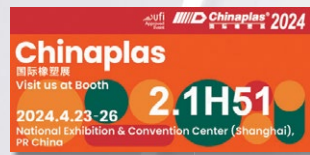

## EXPAND YOUR CAPABILITIES



Your competent partner in plastics processing mixing, dosing, conveying and drying  
Made in Germany

www.koch-technik.com



## swop 2023 Successfully Concludes and Paves the Way for Annual Edition

■ As a member of the interpack alliance, the world's leading processing and packaging exhibition, and as one of the most influential events in the packaging industry, swop (Shanghai World of Packaging) 2023 was successfully held at SNIEC (Shanghai New International Expo Center) from November 22 to 24.

swop is co-organized by Messe Düsseldorf (Shanghai) and Adsale Exhibition Services. The three-day exhibition attracted industry leaders, professionals, and visitors from all over the world to discuss the latest technologies and developments in the processing and packaging industry.

Close to 30,000 trade visitors attended the event, which marked a positive return after 4 years' preparation.

With an exhibition area of over 62,000 square meters, swop 2023 attracted nearly 900 domestic and foreign exhibitors and welcomed 30,000 professional visitors from 99 countries and regions. The three-day event showcased a remarkable 14% increase in visitors compared to the previous edition.

swop has garnered extensive support from over 100 domestic and international industry associations in food, daily chemicals, plastics, printing, packaging, etc. swop 2023 welcomed nearly 300 visitor groups from China, Southeast Asian countries, the Middle East, South America and Europe.

Thomas Dohse, Director of interpack at Messe Düsseldorf GmbH, said, "I am pleased to see that swop, as a member of the interpack alliance, has reached a new record with exhibition space and exhibitor and visitor numbers. We were excited to meet face-to-face with exhibitors and visitors who were finally back to swop after a 4-year absence."

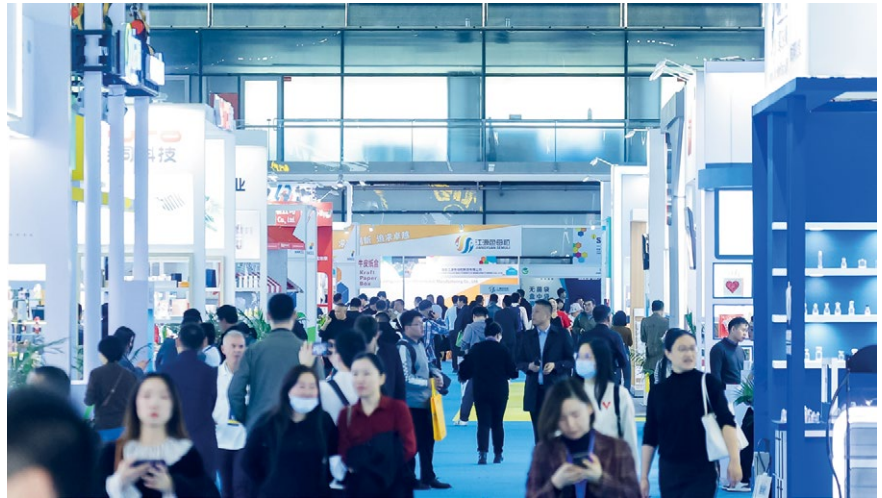

Focusing on sustainable packaging and low-carbon development, swop 2023 introduced a new theme – "Green Power Zone". Over 150 exhibitors displayed diverse eco-friendly packaging materials, production equipment, and solutions to support packaging companies and brands in achieving sustainable development objectives.

swop 2023 launched the "Smart Packaging Zone" to display numerous intelligent plastic and paper packaging containers, packaging machines, and back-end packaging equipment. These products fully meet requirements for intelligence, enabling them to enhance efficiency and reduce costs.

During the show, more than 10 industry forums, new technology exchange sessions, and over 60 thematic discussions were all fully packed with 1,820 participants. Experts, scholars, and corporate leaders were invited to engage in comprehensive and in-depth discourse and analysis of the trendy topics in the packaging industry. Among the highlights was the SAVE FOOD Forum. "SAVE FOOD" is a global initiative jointly launched by the Food and Agriculture Organization of the United Nations (FAO), the United Nations Environment Pro-

gramme (UNEP), Messe Düsseldorf, and interpack. It aims to promote innovation, foster cross-disciplinary dialogue, initiate discussions, and reduce global food waste and loss to contribute to the fight against global food loss.

The 3rd SAVE FOOD China Forum invited experts, scholars and representatives from several organizations and companies.

For the first time, the SAVE FOOD Initiative presented the SAVE FOOD DESIGN AWARD and SUSTAINABILITY DESIGN AWARD to exhibitors at swop. The SAVE FOOD DESIGN AWARD acknowledged innovative products that minimize food waste, while the SUSTAINABILITY DESIGN AWARD celebrated solutions with positive environmental impacts, such as reducing CO<sup>2</sup> footprints. UNIDO, The World Packaging Organization (WPO), and FAO served as jury members for evaluating the applicant companies.

The successful conclusion of the exhibition marks another milestone in the packaging industry. swop will be held annually, and the next edition is scheduled at SNIEC (Shanghai New International Expo Centre) from November 18 to 20, 2024.

## Success Stories from Cairo – Food Africa and pacprocess MEA 2023 End with a New Record

■ Food Africa and pacprocess MEA 2023 ended in Cairo with a significant increase in visitor numbers and strong international participation. The trade fairs thus confirmed their position as leading platforms for the food and packaging industry in Africa and the Middle East.

More visitors than ever before travelled to Egypt this year for Food Africa and pacprocess MEA. With over 900 exhibitors, 27,500 visitors and more than 500 invited buyers, it met with an excellent response. Food Africa and pacprocess MEA, which took place from 12 to 14 December at the Egypt International Exhibition Center, offered a comprehensive marketplace for players in the food and packaging industry. Both trade fairs were jointly organised by IFP Egypt, Konzept Exhibitions & Events and Messe Düsseldorf GmbH under the umbrella of the interpack alliance.

With nine national pavilions and Kuwait as the partner country, the event was characterised by remarkable international participation. The participating nations included Greece, Germany, India, Pakistan, Italy, Spain, Poland, Turkey, China, Thailand and the United Arab Emirates. In total, exhibitors came from 32 countries.

"With inspiring ideas, genuine innovative strength, lots of energy and passion, everyone involved has set new standards," says interpack Director Thomas Dohse



at the end of the three-day trade fair. "The event is a catalyst for trade and cooperation in a dynamically growing region. We are proud of what we have achieved and look forward to continuing this success story next year." Looking to the future, Thomas Dohse announces that Food Africa and pacprocess MEA will be further strengthened as central platforms for the industry.

In 2024, Food Africa and pacprocess MEA will take place from 3 to 5 December.

➔ [www.pacprocess-mea.com](http://www.pacprocess-mea.com)

➔ [www.foodafrica-expo.com](http://www.foodafrica-expo.com)

## Encouraging Preliminary Results

■ According to estimates by the Amaplast-MECS Statistical Study Center, in 2023 the Italian plastics and rubber machinery production could set a new all-time record for the sector of over 4.8 billion euros, racking up a gain of at least three points over 2022. This is mainly due to a positive trend in exports – which improved progressively over the nine months assessed by the Italian Institute of Statistics (ISTAT) – that have increased by 13% compared to January to September 2022. In the same period, imports have increased by 6% while the active trade balance has increased by sixteen points.

Exports – accounting for more than 70% of national production for the sector – show robust growth with a positive trend in all main machinery types for primary processing and those boasting the highest share of the total: moulds (24% share and +14% with respect to January-Sep-

tember 2022); extruders (12% and +22%), injection moulding machines (5% and +2%), blow moulding machines (4% and +17%), but also figuring prominently are machines for moulding and forming (4% and +22%), flexographic printers (4% and +18%), and machines for foamed products (4% and +40%).

Geographically speaking, Europe confirms its status as primary destination of products made in Italy for the sector, with an overall share of 56%. EU countries account for 45% and sales within this market show the most positive results: Germany (+7%), France (+23%), and Spain (+19%). Two EU countries have made it into the top ten commercial outlets after a significant increase in exports: Romania (+71%) and the Czech Republic (+38%). We have also seen a robust increase in deliveries to Russia, in spite of all the well known issues associated with this country: +61%.

The export trend to the Americas is more than satisfying (+24%), thanks to a new surge in USMCA markets – Mexico in particular – and to the continuing ebullience of a number of South American markets, with Brazil, Argentina, and Peru leading the pack.

The Middle East has also shown a rather positive trend on average, driven principally by two markets: Saudi Arabia (+107%) and Israel (+47%).

Exports to the Far East, on the other hand, have witnessed a sudden deceleration (-12%), due essentially to the contraction of two principal markets – China (-15%) and India (-6%) – but also to a loss of momentum in other prominent destinations: South Korea (-61%), Japan (-47%), and Taiwan (-68%). The contemporaneous surge in sales to Thailand (+140%) and Indonesia (+81%) was not sufficient to counterbalance this slump since these two destinations

have limited relative weight in the overall equation.

In light of its excellent performance in January to September 2023, Africa as a whole now boasts nearly a 6% share of the total. Sales to all countries bordering on the Mediterranean have increased greatly, while worth mentioning are South Africa and Nigeria in sub-Saharan Africa, the largest markets in that region with values that have more than doubled since last year.

Beyond the import-export statistics, the concerns of Italian firms in the sector are focused on the progressive downturn in orders in recent months. However, at year's end 2022, no one would have wagered on the positive results we are seeing for 2023: there were fears of a crisis of demand already in the first few months of the new year although it did not actually materialize until the second half of the year.

There are a number of economic and geopolitical criticalities characterizing the international context. The post-pandemic rebound – which reaffirmed the capacity of the industry, which suffered less than its counterparts, to respond positively to adversity – was followed by other negative impacts: from wars to shortages in electronic (and other) components and the volatility of raw material and ener-

gy prices, from slowdowns in some global economies (such as Germany, closely linked to Italy) to increasing inflation and cost of money. While some commodity prices have returned to relatively acceptable levels, there remains an underlying uncertainty that hampers investment planning by firms, which is falling back this year and expected to come to a standstill in 2024.

The CONFINDUSTRIA Statistical Unit sees Italian GDP growing by a mere 0.7% in 2023 (thanks mainly to gains in the first half of the year that then began to erode in the second), and 2024 could be even worse at +0.5%.

The responses of Amaplast member companies to economic surveys covering the first three quarters of this year corroborate this climate of uncertainty, evidencing that revenues from domestic sales have contracted from one quarter to the next and at an increasing rate with each passing month. While revenues from sales abroad have grown, this trend showed signs of slowing down in the third quarter.

The domestic market has also not been kind to these Italian manufacturers as regards orders, which remained significantly below 2022 levels in the first three quarters of this year. Again, while the same indicator is positive when considering

foreign customers, the trend is progressively weakening.

In effect, the slowdown in domestic demand may be considered cyclical to some extent, especially after the peak recorded in 2021, boosted by investment incentives.

"Precisely to address the challenges of the markets," underscored Massimo Margaglione, Amaplast President, "it is increasingly important for companies to implement digital development plans, applying the models that will govern the future of the entire industrial machinery sector and revolutionize company organization, products, and services." He added that "Digitalization is now coupled with servitization, which not only favours and optimizes industrial relations – that is, the relations between technology suppliers, machinery manufacturers, and end users – but offers benefits in terms of sustainability." Margaglione concluded by noting that "Another new and rapidly evolving reality, one which companies are having some difficulties in embracing, precisely due to the ceaseless introduction of updates, is generative artificial intelligence, which offers application potentials that have yet to be fully grasped."

AMAPLAST

➔ [www.amaplast.org](http://www.amaplast.org)

## Top Employer in the Medium-Sized Business Sector

■ SIKORA is one of the top employers in the medium-sized business sector 2024 and ranks place 7 in the area Electric/Electronics, according to Focus-Business and its research partner, FactField GmbH.

As part of the survey, 650,000 employee evaluations, which resulted from an online survey and existing online evaluations of employers, were analyzed from 36,000 companies. Companies with at least one location in Germany and a size of between 11 and 500 employees that achieved at least ten company evaluations with an average rating of at least 3.5 on a scale of 1 to 5 via all data sources were taken into account. The final ranking of the companies resulted from the rating average and the number of ratings depending on the number of employees. Around 4,000 employers with the best scores across all groups were included in the final ranking.

SIKORA employs around 400 people in Bremen and its 13 international subsidiaries. In addition to its own com-



*New work environments in the "Creative Deck"*

pany restaurant and company health management with massages and yoga classes, the company offers many benefits such as flexible working hours, capital-forming benefits, individual training opportunities and regular employee events to promote exchanging and getting to know each other. At the "Creative Deck" on the top

floor of the production building, employees find new working environments with numerous creative areas, quiet workplaces and extended meeting rooms.

**SIKORA AG**  
www.sikora.net

*Holger Lieder, Executive Board at SIKORA AG, with certificate of the "Top Employer Medium-Sized Businesses 2024":  
"The numerous positive evaluations of our company fill us with pride. Only with highly motivated employees, who feel comfortable in their working environment, we can distinguish ourselves from other companies and be successful on the market in the long run. Therefore, we also attach great importance to working together in an appreciative manner and to making the working conditions at SIKORA as attractive as possible."*



**Zumbach**  
SWISS PRIME MEASURING SINCE 1957



min

2

Min. object diameter (mm)

max

100

Max. object diameter (mm)



up to 20

Scan rate (scans/s)

# RAYEX® S

## Static X-Ray Measuring System

### Benefits:

- ✓ All in one! Complete system for precision measurement of wallthickness, ovality, eccentricity and diameter.
- ✓ Fast measurement, immediate response to product changes.
- ✓ Operator friendly due to smart measurement algorithms.
- ✓ State of the art connectivity with integrated Profinet IO, Ethernet TCP/IP, Ethernet IP, or OPC UA communication protocols.
- ✓ Minimum maintenance requirement.



### Zumbach Electronic AG

Hauptstrasse 93 | 2552 Orpund | Schweiz  
Telefon: +41 (0)32 356 04 00 | sales@zumbach.ch  
www.zumbach.com

## Four Carbon Black Plants Awarded ISCC PLUS

■ Orion announced a fourth plant has earned International Sustainability and Carbon Certification (ISCC PLUS). The company now leads its industry with the number of certified carbon black production sites.

Orion's facility in Cologne, Germany, was the company's latest plant to pass extensive audits confirming the site's compliance with rigorous ISCC PLUS sustainability requirements. The plant was certified for producing circular and bio-circular raw materials.

"Orion has long been a leading innovator developing circular solutions and sustainable products for customers," Orion CEO Corning Painter said. "ISCC PLUS verifies the transparency and traceability of sustainable raw materials in our value

chain. It also shows our dedication to sustainability."

In 2022, Orion was the first to achieve ISCC PLUS for multiple carbon black grades made from different feedstocks at plants in two regions of the world. The facilities were in Borger, Texas; Belpre, Ohio; and Jaslo, Poland. The three facilities were recertified this year.

"In addition to recognizing the sustainable grades for rubber applications produced in the three plants, the certification of our Cologne plant is an important milestone for Orion's sustainability efforts because the facility produces a wide variety of specialty products for several applications, including batteries, coatings, printing and polymers," Painter said.

A decade ago, Orion was the first major producer to develop and commercialize carbon black made from renewable feedstocks, such as industrial-grade vegetable oils or other oils derived from waste and residues of biological origin from agriculture or forestry.

Orion is also the only carbon black producer in the BlackCycle initiative, an EU-funded project focused on developing the production of circular carbon black.

The ISCC PLUS certification is granted by the Cologne-based ISCC Association, which promotes the sustainable production of biomass, circular and bio-based materials and renewables.

Orion S.A.

➔ [orioncarbons.com](http://orioncarbons.com)

## Expansion with Additional Services in Malaysia

■ MAAG Group has again expanded its operations in Asia, announcing new services in Malaysia for MAAG Ettlinger melt filters. Now, in addition to, cutting rotor regrinding, MAAG Malaysia can also provide vacuum pyrolysis oven cleaning.

In plastics processing some components have to be repaired, upgraded, or replaced during the long plant life-cycle. MAAG Malaysia offers our customers comprehensive repair services for their polymer production plants. The facility serves most of Asia.

Ueli Thuerig, President of MAAG Group, said: "We are excited about our new Malaysian growth. This project marks another important milestone in the implementation of the company's plan to grow capacity in strategic markets where we expect strong long-term demand."

These additional services are the latest example of MAAG's commitment to the Asian market.



Team MAAG Malaysia

MAAG Group

➔ [www.maag.com](http://www.maag.com)

## Setting the Course for the Future

■ Effective January 1, 2024, Matthias Ruff became an authorized signatory at the SKZ Plastics Center in Würzburg. Equipped with this power of attorney, Ruff will be able to perform his duties as Sales Manager Education and Research even more intensively and flexibly.

"By granting Matthias [Ruff] power of attorney, we are underscoring his

professional expertise, performance and high level of personal commitment. We are thus creating the conditions for further healthy national and international growth in our education and research activities," says Benjamin Baudrit, Deputy Managing Director Education and Research.

Matthias Ruff is pleased and reports: "In recent years, the SKZ has

continued to develop professionally with new research groups, for example in the areas of recycling management and digitalization. The establishment of the TZQ (Training Center Quality) and the development of new digital learning formats such as WBTs (web-based training) have also created various new training options. I am very much looking





Matthias Ruff  
(Photo: Luca Hoffmannbeck, SKZ)

forward to the tasks and opportunities that lie ahead and would like to thank you for your trust".

SKZ has been a sought-after partner for companies in the plastics industry for many years, both nationally and internationally. The granting of power of attorney to Matthias Ruff is intended to consolidate and further expand the paths taken so far.

Matthias Ruff has been with SKZ for five years as Sales Manager Education and Research. He has experience in setting up sales and marketing structures, in customer

development and in establishing and expanding strategic partnerships. He is also one of the two voices of the popular SKZ podcast "Kunststoff: nachgefragt". The European Green Deal, with the goal of a completely CO<sub>2</sub>-neutral EU by 2050, also influences the research areas of the EZD in Selb. Currently, EZD scientists are intensively researching bio-based, sustainable and non-toxic formulations and coatings.

SKZ – Das Kunststoff-Zentrum  
➔ Matthias Ruff, m.ruff@skz.de

## Management Change

■ Ralf Benack takes over KraussMaffei's Extrusion EMEA from January 1st, 2024. As Managing Director, he is responsible for the Extrusion EMEA's business and the development of the Extrusion technology worldwide.

Ralf Benack says, "I am very much looking forward to becoming part of the KraussMaffei Extrusion team and driving the business forward together with all my colleagues! Together, we will continue to impress our customers

with our innovative extruder solutions."

CEO Chi Zhang says, "I warmly welcome Ralf Benack to KraussMaffei. With his many years of experience in management positions in EMEA and APAC and his expertise in the design, sale and implementation of integrated solutions for customers, he will lead KraussMaffei Extrusion EMEA to a next stage and develop the technology together with the global team. I am very much looking forward to working with him."



KraussMaffei Technologies GmbH  
➔ www.kraussmaffei.com

## Personalia

■ In mid-November 2023, Stefan Musner took over the role of Sales Director at Next Generation Recycling Machines GmbH, thereby strengthening the company's leadership team. With his extensive expertise in international sales and almost a decade of experience in the plastic industry, Musner brings a wide range of skills to lead and further develop NGR's global sales.

Stefan Musner has comprehensive commercial and technical educational background and harbors a deep personal passion for resource-efficient technologies. With over 20 years of experience in machine and plant sales, Musner will play a significant role in the strategic orientation of international sales at NGR



in his new role as Sales Director. Together with his sales team, he will

*Stefan Musner: "As a father of two young sons, waste reduction and the promotion of sustainable solutions are particularly important to me. The opportunity to actively contribute to a better future by joining NGR, a technological pioneer in plastic recycling, particularly inspires me."*

strengthen the existing sales structures and explore new ways to be prepared for upcoming challenges in plastic recycling.

With this appointment, NGR remains true to its principles, continuing to focus on customized technical solutions, close customer contact, and the strengthening of the global sales & distribution partner network.

Next Generation  
Recyclingmaschinen GmbH (NGR)  
➔ www.ngr-world.com

## Team with Design Engineers Expanded

■ Guill Tool, global leader in extrusion tooling, recently announced the hire of two new employees. Nick Comeau and Brandon Ribeiro join Guill as Design Engineers.

As a Design Engineer at Guill, Nick Comeau has several responsibilities including new product design concept generation and research and defining customer requirements using job quotations, purchase orders and customer interaction. He also develops the design concept for customer requirements, works on the detailed design using SolidWorks (Computational Fluid Dynamics (CFD) and Computer-Aided Engineering (CAE) programs), database searches, along with proprietary design tools. Next, Comeau prepares the design to release it to operations for manufacture by ensuring accurate and complete drawings and Bill of Materials (BOMs), performs project reviews to define and implement process/product improvements and presents to customers at trade shows.

Brandon Ribeiro's work at Guill involves creating extrusion die assemblies to the requirements specified by the customer. The details are acquired by the sales team along with reference assembly pre-



Brandon Ribeiro

viously created. Once the assembly is completed, Ribeiro contacts the customer to get approval before sending the job to the shop floor for production.

Asked what he likes about working at Guill, Comeau said he's enjoyed the hands-on-experience and that operating and cleaning assemblies shows the strengths and area for improvement of the current assemblies Guill uses. Discussing what he's looking forward to learning he said, "I'm looking forward to learning more about CFDs and how similarly we can replicate real world application within a simulation."



Nick Comeau

Ribeiro appreciates seeing the friendly faces at Guill that are always ready to lend a helping hand. He's enjoyed learning how to create complex geometry using the company's 3D CAD software, SolidWorks.

Commenting on the new hires, Paull said, "We are excited to have Nick and Brandon join the Guill family. They are young professionals eager to learn all they can about the extrusion process to better serve our customers."

**Guill Tool & Engineering**  
Tom Baldock, Sales Manager, Extrusion  
▶ [tbaldock@guill.com](mailto:tbaldock@guill.com)

## Increased Presence in Eastern Europe



*FLEXAL employees during intensive training at Hellweg in Rötgen. From left to right: Mark Hellweg, Managing Director of Hellweg Maschinenbau, Mariusz Kruk, Michał Malecki and Marek Kopacki, Managing Director of FLEXAL (© Hellweg Maschinenbau)*

■ FLEXAL, Posnan, is now a sales partner of Hellweg Maschinenbau in Poland. The company will be responsible for sales, maintenance and technical advice for the complete range of Hellweg grinders.

As a distributor of leading global manufacturers of machines for thermoplastics and rubber processing as well as automation solutions, FLEXAL has over twenty years of experience in machine sales and extensive knowledge of the technological processes used in the plastics industry. In addition to grinders from Hellweg, the FLEXAL product range also includes pellet dryers, centralised feeding systems, conveyor belts, laboratory extruders, robots, dosing devices and much more.

Hellweg is a global manufacturer of digitally controlled grinders for effective, energy-saving plastics recycling. The portfolio ranges from small units for grinding sprues to high-performance systems for solid parts, films and sheets with a throughput of five tonnes per hour and more.

The MDSi 340/150 Smart Control machine-side-grinder is the most powerful model in the series with drive out-

puts from 1.5 kW to 4 kW for grinding capacities from 10 kg/h to 80 kg/h. Its main area of application is the raw material-saving return of even the bulkiest sprue stars, sprue spiders or sprue ladders directly to one or more injection moulding machines. A feed device for film edge trims is optional.

The central grinders in the 300 series from Hellweg combine a compact design with high performance. Thanks to the sturdy machine housing and the high moment of inertia of the massive, solid rotor, they enable high-throughput shredding of thick-walled moulded parts, plates, sprues, pipes and profiles and, when using a special BR version rotor, even the single-stage shredding of massive start-up lumps.

Hellweg's newly developed MDSGi 1500/600 wet grinder is equipped with a forced feed system, for film recycling. Robust and durable, it offers an unrivalled ra-

tio between throughput and energy consumption, resulting in very low operating costs. Its cutting geometry is also outstanding, producing flakes with consistently optimum quality and perfect particle size distribution and geometry for further processing.

The digital Smart Control system, which is part of all systems, records parameters such as power consumption, motor speed and bearing temperatures as well as the condition of blades, screens and V-belts. Because it can continuously optimise the ratio between motor load and throughput, it ensures particularly economical operation with minimal effort for the operating personnel.

Hellweg Maschinenbau GmbH & Co. KG  
 ► [www.hellweg-maschinenbau.de](http://www.hellweg-maschinenbau.de)  
 FLEXAL Group Sp. z o. o.  
 ► <https://flexal.pl/>

## Personalia

■ The Supervisory Board of Borealis has appointed Craig Arnold as the new Executive Vice President Polyolefins, Circular Economy Solutions and Innovation & Technology with effect from February 1, 2024.

"I am delighted we bring such an experienced Commercial executive onboard of the Borealis Executive Board. I warmly welcome Craig and look forward to

working closely with him," comments Daniela Vlad, Chairwoman of the Borealis Supervisory Board and OMV Executive Vice President Chemicals & Materials.

Borealis Group  
 ► [www.borealisgroup.com](http://www.borealisgroup.com)

## Personalia

■ European Bioplastics (EUBP) announces that Stefan Barot (BIOTEC) stepped down as Chair and member of the Board of European Bioplastics (EUBP) with immediate effect. Until a successor is elected, Mariagiovanna Vetere

(NatureWorks) and Lars Börger (Neste) will take the reins of EUBP as Acting Co-Chairs.

In a letter received on 6 November 2023 and addressed to the Managing Director of EUBP, Hasso von Pogrell, Stefan Barot announced his resignation as Chairperson and member of the Board of EUBP with immediate effect, citing personal and professional reasons compelling him to take this extraordinary step.

In an extraordinary Board meeting, Mariagiovanna Vetere and Lars Börger confirmed their availability and willingness to step in as Acting Co-Chairs to lead the association until a successor has been elected. On behalf of the Board, both expressed their gratitude towards Stefan Barot, thanking him for his near year-and-a-half of dedication in steering the association and driving it forward.

The EUBP Managing Director and staff thank Stefan Barot for his work and wish him well for his future endeavours.

European Bioplastics (EUBP)  
 ► [www.european-bioplastics.org](http://www.european-bioplastics.org)



ERGE Elektrowärmetechnik - Franz Messer GmbH  
 91220 Schnaittach - Hersbrucker Straße 29-31  
 Tel. +49/9153/921-0 Fax +49/9153/921-117  
[www.erge-elektrowaermetechnik.de](http://www.erge-elektrowaermetechnik.de)  
 mail: [verkauf@erge-elektrowaermetechnik.de](mailto:verkauf@erge-elektrowaermetechnik.de)

HEIZEN

HEATING

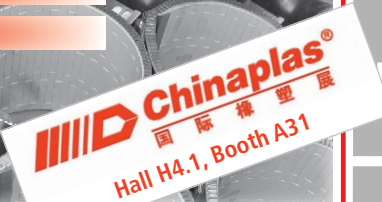

TROCKNEN

DRYING

REGELN

CONTROLLING

ELEKTROWÄRMETECHNIK FRANZ MESSER GMBH

## Support from Europe for Trade Fair Plástico Brasil

■ The next Plástico Brasil, exhibition for plastics and rubber machinery, is scheduled to take place in São Paulo from 24 to 28 March 2025. The entire plastics industry supply chain will be represented at this event.

Plástico Brasil will be hosted by ABIMAQ (The Brazilian Association for the Machinery and Equipment Industry) while INFORMA MARKETS LTDA, one of Brazil's largest trade show promoters, is entrusted with the organization of and publicity for the trade show.

In the spirit of mutual support, INFORMA and EUROMAP have now agreed on working more closely together. The collaborative approach comprises enhanced exchange of experience, involvement in the bodies of Plástico Brasil, support in recruiting exhibi-

tors and attracting visitors and the establishment of joint networks.

From now on, the Plástico Brasil will be labelled "Supported by EUROMAP". This endorsement is only given to a limited number of events worldwide to maintain high quality standards.

Brazil is a market with great potential. It is an important and promising market for the EUROMAP countries where they want to see themselves represented at a high-profile exhibition.

The Plástico Brasil will take place in Brazil's largest and most modern exhibition center, the São Paulo Expo Exhibition & Convention Center.

**EUROMAP**

➔ [www.euromap.org](http://www.euromap.org)

## "Premium Partner Research" Award Received

■ Starting in 2024, the SKZ Plastics Center will award the coveted "Premium Partner" distinction not only to educational partners, but also to research partners retroactively for the year 2023. ColVisTec from Berlin is one of the first award winners and is being honored for years of successful cooperation in research and development.

For several years, the SKZ Plastics Center has been honoring close partners in the field of education with the "Premium Partner Education" award and has already presented a corresponding plaque to various companies in the plastics industry. Starting in 2024, the Würzburg-based institute will also present the award to long-standing research and development partners in the various fields of activity. ColVisTec is thus one of the first winners in the research category.

"We would like to thank SKZ not only for the current excellent cooperation, but also for the many years we have worked together on various projects," says Dr. Linda Mittelberg, Group Leader Spectroscopy at SKZ. "I can't remember a year in the last ten years when we haven't worked together with SKZ on a research project. We already have the next ideas in the pipeline and look forward to continuing this successful cooperation," adds Fuat Eker, Director of Sales, Marketing and Customization at ColVisTec AG.

Research in the field of spectroscopy primarily serves the further development of inline measurement methods for quality assurance in the plastics industry. ColVisTec develops, adapts and applies unique technology and software solutions based on inline UV-Vis spectrophotometry for the coating, pharmaceutical, plastics and chemical industries. The two partners have already achieved numerous successes, such as the recently completed ZIM project "RecyColor", in which the color of recycled material can be automatically corrected.



*Fuat Eker, Director of Sales, Marketing and Customization at ColVisTec AG, receives the Premium Partner Research plaque from Dr. Linda Mittelberg, Group Leader Spectroscopy at SKZ (Photo: René Bauer, SKZ)*

**ColVisTec AG**

➔ [www.colvistec.de](http://www.colvistec.de)

**SKZ Plastics Center**

**Dr. Linda Mittelberg, [l.mittelberg@skz.de](mailto:l.mittelberg@skz.de)**

➔ [www.skz.de](http://www.skz.de)

## Investment in Global Service Capabilities to Bolster Customer Service and Support

■ Davis-Standard expands its service and support capabilities focused on delivering better line efficiency and lower operating costs to its customers. The company's investments in one global service team, critical spare parts inventory, new service products and advanced digital infrastructure are to address customers' need for speed, uptime, flexibility, cost savings and quality. These enhanced capabilities are designed to support all equipment manufactured by Davis-Standard and its subsidiaries, including Maillefer.

Giovanni Spitale, CEO of Davis-Standard, was quoted as saying, "Davis-Standard's commitment extends far beyond the initial equipment sale – it's about building enduring partnerships that empower our customers to thrive, and we firmly believe the strategic investments in our people, technologies, and operations will provide an immediate impact to our customers."

Davis-Standard's investment spans into four core areas. First, an expanded network of expert service technicians to ensure localized support for customers. For US-based customers, the goal is to have a Davis-Standard certified technician within a 3-hour radius of customer sites, ensuring faster resolution of customer

issues. Second, the company stocks 1000+ critical spare parts in its VIP program for its customers. This ensures a 24-hour part availability from a trusted source with predictable costs. Third, to minimize unplanned downtime and increase line performance and throughput, Davis-Standard has flexible preventative maintenance programs customers can choose from, including rebuild and repair programs. Lastly, the company has significantly invested in a Service Cloud, advanced data analytics, and remote monitoring/IOT capabilities. Coupled with the digital transformation, the increase in sustaining innovations, such as product upgrades, ensures the complete life cycle of the equipment is optimized.

"Our customer-centric approach drives everything we do. We've restructured internally and expanded our service offerings to ensure unparalleled operational excellence for our customers. Buying equipment from us means a lifelong partnership geared towards enhancing customers' line efficiency at a competitive total cost of ownership and fostering future innovations," said Zachery Ament, Global Service President.

Davis-Standard

www.davis-standard.com

## Distribution Partnership in Italy Signed

■ At the beginning of 2024, SKZ Plastics Center will enter the Italian plastics market together with its new sales partner Prochema Srl. Prochema has been an integral part of the Italian plastics market for many decades in the areas of plastics processing machinery, extrusion and recycling, and already represents various players in the industry on the market.

"With Prochema, SKZ now has a partner in the Italian market who knows the needs of potential customers, has strong ties to the plastics industry, and will actively raise the profile of SKZ in Italy in cooperation with the headquarters in Würzburg," says Matthias Ruff, authorized signatory and head of Sales Education & Research at SKZ.

The new SKZ sales agency will distribute all SKZ training courses – including classroom training in Germany, on-site training in Italy, live online courses from the SKZ online studio and web-based training. In the area of training, SKZ is a knowledge provider from the shop floor to C-level. SKZ's research and development services also extend to the Italian plastics market.

"This collaboration will help our customers to achieve and improve their goals, thanks to the structure and the technical and pedagogical skills of SKZ", says Marco Leone Zimmer, CEO of Prochema. Benjamin Baudrit, Deputy Managing Director Education & Research at SKZ, concludes: "SKZ has been active internationally for



SKZ and Prochema at the signing of the partnership agreement; from left: Matthias Ruff, authorized signatory and SKZ Sales Manager Education & Research; Marco Leone Zimmer, CEO Prochema Srl; and Dr. Benjamin Baudrit, SKZ Deputy Managing Director Education & Research (Photo: Katrin Heilig, SKZ)

years and we have not really been present in Italy with our training activities. This is about to change!"

SKZ Plastics Center  
 Matthias Ruff, m.ruff@skz.de  
 www.skz.de

## Pure Material, Best Quality – 10 Years PURITY SCANNER ADVANCED

■ In 2013 SIKORA launched with the PURITY SCANNER a new type of technology on the market that differed significantly from existing technologies. The development of a system for inspection and sorting of pellets was achieved in close cooperation with partners from the power cable industry. Today, the device is established on the market and helps users during sorting for the highest quality and sustainability.

Particularly in the production of high-voltage cables, it is essential that no metal contamination, which can occur during production, gets into the insulation of the power cables. The aim was then and now to detect and sort out impurities in the plastic pellets. A particular challenge was to detect impurities even if they were melted into the pellet. The PURITY SCANNER's unique combination of X-ray technology and a flexible optical system laid the foundation for 100 % inspection of plastic pellets already ten years ago. Discolorations and black specks in transparent or on translucent and colored raw materials are detected by up to three optical black and white cameras. In addition, the X-ray camera detects metallic contaminants from 50 µm in size in the pellets. The contaminants are then automatically sorted out so that only pure material is processed further. The system has been continuously developed since its introduction. The PURITY SCANNER ADVANCED, the successor to the PURITY SCANNER, has now been successfully established on the market. Depending on the material and requirements, the customer decides how many and which camera types are used.

The pellets are conveyed via a wear-free vibrating chute made of stainless steel, which is perfectly encapsulated to create a clean room within the system. The pellets fall evenly down the inspection area via the vibrating chute.

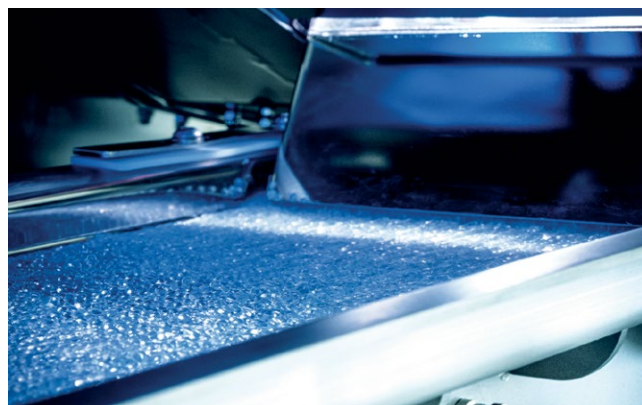

*With the PURITY SCANNER ADVANCED, the pellets are conveyed to the inspection area via a stainless steel vibrating chute*

This creates optimum conditions for optical inspection from the various camera viewing angles. With the PURITY SCANNER ADVANCED, customers have also the option of adapting the by-catch to the respective application using hybrid blowing. For rarely occurring, larger burns or metal contamination, for example, a larger ejection can be set than for small, light discolorations that are not critical.

Thanks to the combination of the highest possible detection and hybrid blowing, the PURITY SCANNER ADVANCED enables material of the highest quality. This further optimizes production processes, and the reduced bycatch contributes to cost-efficient and sustainable production.

SIKORA AG

► [www.sikora.net](http://www.sikora.net)

## Acquisition

■ Borealis announces the signing of an agreement to acquire a 100 % stake in Integra Plastics AD, an advanced mechanical recycling player based in Bulgaria.

The investment will strengthen Borealis' advanced mechanical recycling portfolio, adding more than 20,000 tons of recycling capacity and support growing customer demand for sustainable solutions.

The transaction is part of commitment to accelerate the transition to a circular economy and represents another critical proof point of that ambition.

Based in Elin Pelin, Bulgaria, Integra Plastics AD operates a modern advanced mechanical recycling plant built in 2019 with state-of-the-art equipment. Integra Plastics has the ability to transform post-consumer waste into high quality polyolefin recyclates suitable for demanding applications.

"In line with Borealis' Strategy 2030, we continue making steady progress on our circularity journey by reinventing essentials for sustainable living. The addition of Integra Plastics AD will strengthen our ability to



*Integra Plastics AD aerial view (© Integra Plastics AD)*

deliver on our advanced mechanical recycling ambition and enable our customers to meet their sustainability targets," says Lucrece Foufopoulos, Borealis Executive Vice President Polyolefins, Circular Economy Solutions and Innovation & Technology.

Borealis

► [www.borealisgroup.com](http://www.borealisgroup.com)

► [www.borealiseverminds.com](http://www.borealiseverminds.com)

## Focus on Recycling

■ The international ALPLA Group is presenting its fifth sustainability report under the motto 'What we do matters'. In it, the packaging and recycling specialist analyses the financial years 2021 and 2022 and focuses on the three pillars of „People“, „Planet“ and „Profitability“. ALPLA is on track in spite of growth and global expansion thanks to energy efficiency measures and investments in the circular economy. The proportion of recycled material was increased from 16 per cent to 18 per cent between 2021 and 2022 and is expected to reach at least 25 per cent by 2025.

The report focuses on business-relevant issues such as climate protection, resource efficiency, equal opportunity, and legal and regulatory changes. Data, charts and examples document the progress made and show where there is potential. „Every day, we champion solutions that promote safe, affordable and sustainable life around the world. With more than three billion people coming into contact with our products every day, we are assuming the great responsibility that comes with our mission,“ emphasises ALPLA CEO Philipp Lehner.

High-quality data forms the basis for targeted climate protection measures. ALPLA has developed a detailed calculation of the carbon footprint for all the regions, plants and divisions. The carbon footprint is to be further reduced by making increased use of renewable energy and with initiatives to promote the circular economy. These



include lightweight packaging, in-house production directly at the customer's premises, investments in state-of-the-art recycling plants and innovative projects with plastic alternatives.

Energy consumption remained constant in 2021 and 2022 despite the growing material needs. The share of renewable energy was increased by one percentage point from 2021 to 2022 to the current level of 22 per cent. Numerous plants in Austria, Germany, Spain, Portugal, Poland, Mexico, Costa Rica and Panama are already run entirely on renewable energy and more sites are scheduled to follow in the coming years.

In line with the Ellen MacArthur Foundation's New Plastics Economy Global Commitment, ALPLA intends to be using at least

*ALPLA realizes safe, affordable and sustainable plastic packaging solutions (Pictures, Copyright: ALPLA)*

25 per cent recycled materials in its packaging by 2025. In 2021, 282,050 tonnes of recycled material were used, equating to around 16 per cent of the material needs. By 2022, this had already gone up to 327,520 tonnes or 18 per cent of the total needs. Increasingly recycling used plastics is an important lever for reducing greenhouse gases and will be further promoted through investments in recycling.

**ALPLA Group**  
 ➔ [www.alpla.com](http://www.alpla.com)  
 ➔ [www.sustainability-report21-22.alpla.com](http://www.sustainability-report21-22.alpla.com)

▶ **Universally applicable – Optimised for your needs.**

No matter if you are manufacturing metallised standard food and non-food packaging, easy-to-recycle stand-up pouches from MOPE film or technical products, SML's cast film lines are always optimised for your specific requirements.

**Extrusion lines.**  
Engineered to perform.





Learn more about **SML's cast film lines.**

[www.sml.at](http://www.sml.at)

# Shaping the Future of the Plastics & Rubber Industries

*The year 2023 marked a turning point for China as doors reopened, revealing a multitude of opportunities and pathways. Under the resumption of normalcy, the economy grew at a rate of 5.2% in 2023, according to the National Bureau of Statistics of China. As the economy recovers, sectors such as automotive, consumer electronics, and e-commerce have regained momentum. At the same time, China's manufacturing industry is undergoing a remarkable transformation, shifting from its traditional "Made in China" reputation to embracing innovation with the concept of "Innovated in China", gaining competitive advantage in the global market.*

CHINAPLAS 2024, the region's foremost platform to promote latest market trends, breakthrough technologies and innovative solutions of plastics and rubber industries, will be staged in Shanghai, China, from April 23-26, 2024.

The new generation of information technology, new energy, bio manufacturing, commercial aerospace, and low-altitude economy are rapidly developing in China. The export performance of China's "new three"—solar panels, lithium-ion batteries, and electric vehicles is particularly impressive. China's high-tech industries enjoy a growth and experience breakthrough in recent years.

These developments signal a positive outlook for market demand for plastics and rubber in China, generating substantial needs for high-performance plastics materials and technology throughout the country. This shifting landscape has magnified the importance of embracing the circular economy, digitalization and the significance of "Innovated in China".

As a flagship event of plastics and rubber industries, CHINAPLAS 2024 will make full use of all 15 exhibition halls, providing over 380,000 square meters of exhibition area and gathering more than 4,000 industrial leaders from all over the world. CHINAPLAS continues



*CHINAPLAS 2024 provides an excellent platform for buyers who are pursuing innovative plastics and rubber solutions to enfold the accelerated industrial transformation*

to drive the growth and development of the plastics and rubber industries with a full range of innovative materials and mechanical technologies that are both advanced and cost-effective.

Circular economy has gained immense importance worldwide as a key strategy for addressing environmental challenges and fostering sustainable development. It is of great prominence in the plastics and rubber industries, which have traditionally been associated with significant waste generation and environmental impact, revolutionizing their approach to production and consumption with transformative solutions to drive sustainability by promoting resource efficiency, waste reduction, and recycling. It encourages the adoption of innovative technologies for plastic

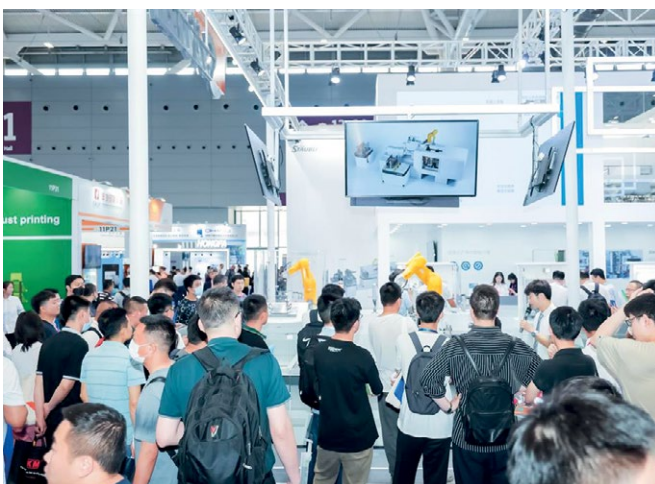

*CHINAPLAS continues to drive the growth and development of the plastics and rubber industries*





and rubber recycling to produce high quality recycled plastics, creating a closed-loop system that maximizes the value of materials, enhancing a more sustainable and circular future.

Promoting the concept of circular economy remains an internationally recognized imperative and a key pillar of China’s economic development strategy to achieve sustainable development of the industry. Prominent enterprises and companies in the world have committed to promote recycling and circular utilization of plastics. In recent years, the plastics and rubber industries have been making relentless efforts to facilitate the transition to a circular economy. Raw material and machinery suppliers have been continuously introducing new technologies for biodegradable materials, recycling, and sustainable solutions. In response to the various needs and interests of the industries, CHINAPLAS 2024 will gather innovative green solutions across 3 theme zones, including Recycled Plastics Zone, Bioplastics Zone and Recycling Technology Zone. Leading material suppliers and recycling equipment manufacturers will showcase their solutions to support the industry’s sustainable development goals. Global stakeholders will be invited to discuss latest plastic recycling trends and share insights in circular economy in the 5th Edition Plastics Recycling and Circular Economy Conference and Showcase which will take place on April 22 in Shanghai.

*Leading material suppliers and recycling equipment manufacturers will showcase their solutions at CHINAPLAS 2024 to support the industry’s sustainable development goals*

Digitalization plays a pivotal role in transforming the industries, unlocking new possibilities and driving innovation in the digital era. Introducing smart manufacturing brings numerous benefits, including enhanced operational efficiency, improved product quality, and streamlined supply chain management. From smart manufacturing and automation to data analytics and IoT integration, digitalization enables real-time monitoring, data-driven decision-making, and predictive maintenance. It also facilitates the adoption of advanced manufacturing techniques such as additive manufacturing and robotics. By harnessing the power of digitalization, the plastics and rubber industries can optimize processes, reduce waste, and respond swiftly to market demands, ultimately fostering sustainable growth and maintaining a competitive edge in an increasingly digitalized world.

CHINAPLAS 2024 will introduce a full spectrum of smart manufacturing solutions and machinery in Injection Molding Machinery & Smart Manufacturing Technology Zone with over 57,000sqm.

“Made in China” holds tremendous global significance in the plastics and rubber industries, symbolizing



*The exhibition will gather more than 850 enterprises which is recognized as “Professionalization, Refinement, Specialization and Innovation (PRSI)”, of which over 250 have been awarded as a “Little Giant”*



*CHINAPLAS 2024 is ready to accommodate more international visitors in Shanghai. Exhibitors shall undoubtedly expect to discover and seize more new business opportunities on the fairground.*

manufacturing excellence and the prowess of Chinese companies. Renowned for their cost-effectiveness and industrial capabilities, Chinese manufacturers have not only established themselves as key players but have also made significant strides in building world-class brands. The "Made in China" label now represents more than just affordability, it also signifies a commitment to innovation and the adoption of high-end technology. Companies in China are increasingly investing in R&D, pushing the boundaries of technological advancements across the plastics and rubber industries. By combining manufacturing expertise with cutting-edge technologies, industry professionals are driving industry growth, offering a diverse range of high-quality products, and solidifying China's position as a global leader in these industries.

This year, in response to the national and provincial policies, the exhibition will gather more than 850 enterprises which is recognized as "Professionalization, Refinement, Specialization and Innovation (PRSI)", of

*CHINAPLAS 2024 will introduce a full spectrum of smart manufacturing solutions and machinery in Injection Molding Machinery & Smart Manufacturing Technology Zone*

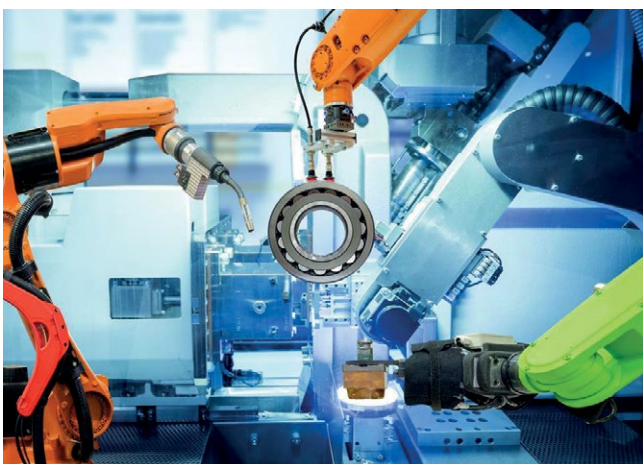

which over 250 have been awarded as a "Little Giant". The goal is to facilitate niche companies' innovations and promote the initiatives of the Government of the People's Republic of China in strengthening the cultivation of niche companies towards "PRSI".

China's foreign trade is experiencing a consistent growth in both scale and quality. Chinese enterprises are proactively expanding into overseas markets, with a focus on the ASEAN countries aligning with their "going-out" strategy and the Regional Comprehensive Economic Partnership (RCEP). In response, CHINAPLAS team has spread its legs across Vietnam, Indonesia, Malaysia, India, Japan, Turkey, Egypt, Mexico, Germany, Italy and Taiwan Region, to invite local associations, enterprises and potential buyers to visit CHINAPLAS.

China has granted visa-free entry to citizens from France, Germany, Italy, the Netherlands, Spain, Malaysia, Thailand, Switzerland, Ireland and Singapore has also introduced new measures to simplify visa processes, making the trip to CHINAPLAS easier and more convenient. CHINAPLAS 2024 is ready to accommodate more international visitors in Shanghai.

Adsale Exhibition Services Limited

▶ [www.ChinaplasOnline.com](http://www.ChinaplasOnline.com)

SCAN TO PRE-REGISTER



# Extrusion Takes Some New Turns

*A longtime global leader in extrusion tooling for medical tubing and other products, Guill Tool has achieved a series of successes in the areas of multi-layer dies and, most recently, a reciprocal tubing die for wound draining that reconfigures the internal chambers of the tubing to accommodate drainage.*

**D**rain tubes can be inserted prophylactically to prevent or remove the accumulation of fluid in a wound. Alternatively, such tubing can also be therapeutically inserted to evacuate an existing collection of fluid in a wound. Fluid is removed in order to treat or prevent infection and promote wound healing and patient comfort. Drain tubes can also be used to diagnose post-operative complications such as an anastomotic leak or hemorrhage. The Guill design has unique features that eliminate the need to weld or otherwise join sections with different profiles together.

"Our automated extrusion process drastically changes the extruded profile in production, with no need to join separate sections of internal profiles," comments Tom Baldock, Sales Manager, Guill Tool

Guill has engineered this new reciprocal tubing die with various features, unique to the product. The traditional tip and die assembly is replaced with a linear reciprocating assembly that changes the tube's profile within a given length. This process is repeated throughout a single extrusion run without interruption. Cutting capability, in association with the extrusion speed, cuts the finished product to length.

While cost and value stream activities are reduced, quality is actually improved. Only one extrusion run is needed to produce a finished product, as opposed to multiple extrusion runs with tooling changes along with a manual assembly operation to connect different tubing shapes via sonic welds or other methods of joining. Guill's new reciprocating head eliminates this entire assembly operation. It also eliminates in-process inven-



*Internal configurations of different designs used on wound drain and surgical tubing no longer require separate sections to be extruded, then joined. The Guill reciprocating head design produces various profiles within the tubing in a constant production run*

tory. Thus, there is no need for storage of various tubing shapes and connectors needed for assembly, fulfillment of orders and replenishment of finished goods.

Furthermore, the reciprocating head eliminates a connecting piece, allows JIT production and products made-to-order. Lastly, it reduces total run time from receiving the order to shipping product.

In the multi-layer extrusion arena, a primary focus of Guill Tool over the years, the company has also introduced the latest generation of its Series 800, the 2-to-6 layer extrusion tooling designed to produce the highest quality, highest material-efficient 1/8" to 6" OD tubing for medical and surgical applications. The redesigned Series 800 produces flawlessly smooth extrusion and layer definition of Fluoropolymer and other materials for all multi-layer, multi-lumen medical tubing. The Guill design further allows thin layer combinations of polymers and adhesives to 0.02mm or less.

Guill offers its extensive line of crossheads and inline tubing dies in fixed and adjustable center, for single or co-extrusion applications. The tooling is designed to process all compounds and features the company's patented, precision Feather Touch Concentricity adjustment, the Seal Right System, which combines with the Feather Touch system to eliminate polymer leaking. Guill also offers its unique spiral flow distribution system.

All Guill tooling is produced with rigorous computer simulation of the flow channels using Computational Fluid Dynamics (CFD) programs, resulting in optimum uniform flow with no weld lines.



*Guill Series 900*

Finally, the new Series 900 of inline tubing dies from Guill Tool offers improved extrusion performance and capabilities to customize at standard, off-the-shelf prices.

The new series is applicable to extrusion of hose or pipe ranging from 0.005" (0.127mm) to 8.0" (635mm) in diameter for all types of OEM, food service, automotive, industrial, telecom and medical applications in polymer or rubber.

The Series 900 technology offers these key benefits:

- Achieves concentricity or "product roundness" which greatly reduces material usage compared with other types of extrusion tooling
- Spiderless inline-designed heads results in no spider lines and allows room for more air – thus eliminating cold legs, which can inhibit product output
- Runs 1 to 5 layers simultaneously
- Engineered for a multitude of applications – including special fluoropolymer applications

A key Guill Tool technical highlight of the Series 900 is a patent-pending FeatherTouch™ adjustment in the die holder and a cartridge-style ball assembly that does not require the loosening of retaining screws to make adjustments. Additional unique benefits of the Series 900 include Guill's Seal Right Systems, a positive seal, which eliminates leakage between deflectors, along with easy self-alignment that reduces operator error during assembly and is adaptable to a variety of specific extruder layout configurations.

"This series offers a standard platform design of the head with specific characteristics that are unique to individual applications included at no additional charge in the cost of the tooling. This is a tremendous benefit to a company that requires precision tooling with custom benefits at a standard off-the-shelf price. That certainly helps our customers' bottom line," says Tom Baldock, Guill Sales Manager.

Guill Tool also manufactures tips, dies, and breaker plates using state-of-the-art computerized CNC ma-

Guill Series 800

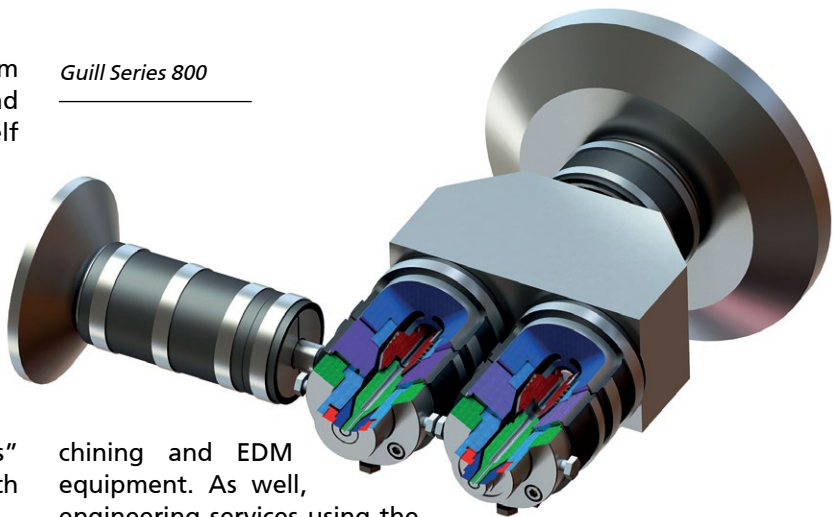

chining and EDM equipment. As well, engineering services using the latest CAD systems are available for custom-designing extrusion tooling product such as crossheads, tips, clamps, flanges, forming rolls, spiderless inline dies, dies, swing gates, breaker plates, special equipment and sizing dies.

Guill Tool received ISO certification in 1995. The first major extrusion tooling company to meet international standards, Guill Tool has long been recognized as one of the leading established designers and manufacturers of custom extrusion tooling for applications including wire, cable, fiber optics, medical tubing, wood composites, automotive tube, plastic compounding, custom applications, rubber, profile, industrial pipe, hose/tube, blow molding, plus food and packaging.

Guill Tool also encourages and provides education and training for the extrusion industry with plastic and aluminum model heads, fully illustrated operating manuals for step-by-step assembly and disassembly, training videos, and classes on the care and cleaning of extrusion tooling.

Founded in Rhode Island in 1962 by A. Roger Guillemette, Guill Tool was established as a job shop supplying tips, dies, crossheads and replacement parts to the wire, cable or wire and cable, plastic and rubber industries in New England. Later, Guill Tool became a supplier for the entire United States and Canada, and today enjoys a worldwide market presence.

Technology in the Medical field is constantly evolving, and often requires an extensive array of Medical grade tubing in a variety of materials and thicknesses. Guill specializes in working with clients to design and manufacture Custom Extrusion Tooling to produce an unparalleled range of the highest quality Medical tubing in the industry. The company's Micro Medical tooling can extrude tube thinner than a human hair, 0.008" or finer per revolution, and can be used to keep procedures as non-invasive as possible. Other models are used to produce tubing for feeding applications, including nasogastric and jejunal tubes.



Guill Tool & Engineering Co., Inc.  
10 Pike Street, West Warwick, RI 02893, USA  
Tom Baldock, Extrusion Sales Manager  
[www.Guill.com](http://www.Guill.com)

# New Filtration Compounder for Higher Product Quality and Reduced Energy Consumption in PCR and Polymer Recycling

*For recycling of post-consumer recyclate (PCR) or any highly contaminated polymer, Coperion has developed the innovative ZSK FilCo filtration compounder that allows filtration and compounding in a single production step.*

**W**ith the new ZSK FilCo system, waste plastic is fed into a ZSK twin screw extruder, where it is melted, homogenized and devolatilized. The melt is then fed through a filter to remove all contaminants before it is fed back into the same ZSK extruder to be compounded with reinforcing materials or fillers.

Compared to the two-step production lines that have been the norm until now, Coperion's new ZSK FilCo is distinguished by a markedly more streamlined equipment set-up. Energy consumption and emissions for the extrusion process are reduced by more than 50%. Moreover, the ZSK FilCo is able to achieve a significantly higher product quality. Recompounds can be produced much faster and Coperion K-Tron gravimetric feeders ensure the high-accuracy incorporation of additives for an optimal result.

## Filtration and Compounding in Single Production System

In conventional recycling plants, PCR and contaminated polymers must first be melted using a single or twin screw extruder, then filtered and pelletized thereafter. For plastics upcycling purposes the filtered recompounds are then fed into a separate twin screw extruder where they are again melted and compounded with the aid of additives, reinforcing materials and fillers before finally being pelletized. In this production set-up, energy for melting must be introduced twice. Along with high energy consumption, the recyclate is subjected to high thermal stress which in turn results in increased degradation, shortening of polymer chains and thus a reduction in product quality.

The new ZSK FilCo makes it possible to melt, filter, compound and pelletize recyclate in a single production system. Waste plastic is fed into the ZSK extruder in the form

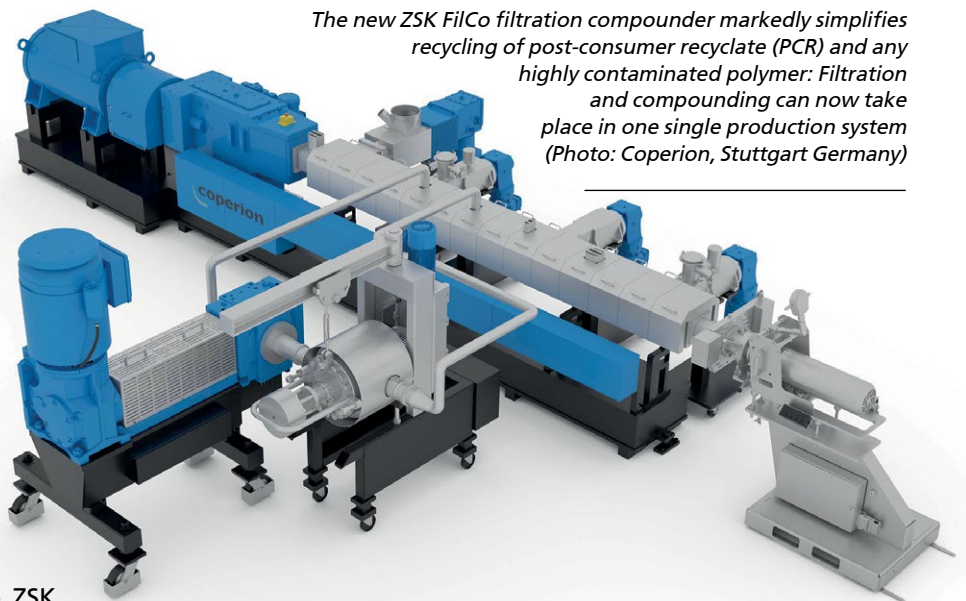

*The new ZSK FilCo filtration compounder markedly simplifies recycling of post-consumer recyclate (PCR) and any highly contaminated polymer: Filtration and compounding can now take place in one single production system (Photo: Coperion, Stuttgart Germany)*

of regrind, fiber pellets, film flakes or agglomerate and is melted, homogenized, and devolatilized there, together with all its components (all polymers, PE, PP, PA, PS, PC/ABS, etc.). Next the melt is fed through an integrated filter that removes all contaminants. Reintroduction into the ZSK extruder process section follows, where reinforcing materials such as glass, wood, and carbon fibers, or fillers such as talc, CaCO<sub>3</sub> or ground PEX are added, after which the recompound is pelletized.

The ZSK FilCo's space requirement is comparatively low. All product streams are added gravimetrically to the process with no fluctuations. The recyclate needs to be melted only once. The ZSK FilCo thus consistently achieves a higher product quality than multi-part systems that have been typically used for this recycling process.

Moreover, energy consumption and emissions for the extrusion process are markedly reduced with the new solution. Thanks to the twin screw extruder's high mechanical energy input, the melting process is more energy efficient than with a single screw extruder. In addition, the second melting process for compounding is completely eliminated in the ZSK FilCo solution and pelletizing of the intermediate compounds is also omitted.

Marina Matta, Team Leader Process Technology Recycling at Coperion, is very proud of this newest Coperion development: "The ZSK FilCo is one more result of our targeted efforts to optimize the recycling of plastics and to further increase the sustainability of the overall process. The ZSK FilCo's excellent energy economy and the high end product quality that it achieves

are important benefits that will once again make PCR and polymer recycling a bit more attractive for many companies."

Coperion GmbH  
Theodorstr. 10, 70469 Stuttgart, Germany  
www.coperion.com

# 100 Metric Tons of PET Recyclate Per Day – *Fifth PET Washing Line to Türkiye*

*The first truck has left the yard. Another 20 will follow. They will deliver the newest washing line from Herbold Meckesheim to Kırklareli, Türkiye, almost 2,100 kilometers away. There, in the European part of Türkiye, the latest recycling plant of the Meckesheim-based special machinery manufacturer is being built for the company Doğa. After commissioning, the washing line is expected to produce a daily output of 100 metric tons of PET recyclate. Doğa, a company hitherto active in the construction industry, intends to sell the recycled PET flakes for bottle-to-bottle applications.*

"As the Doğa Group, we are proud to add the recycling sector to our activities of fields such as real estate, construction, mining and textiles," explains Ömer Ayvaci, Chairman of the Board of the Doğa Group. "In today's world, where the concepts of environmentally friendly production are becoming increasingly important, we aim to start rPET flakes production with completely environmentally friendly solutions with our state-of-the-art machinery park as of the beginning of next year." Ömer Ayvaci emphasizes: "We are confident that we will meet the needs of the sector with Herbold Meckesheim, a company that has mechanical recycling technology accepted all over the world. With the technical information, support and know-how provided by Herbold Meckesheim,



*Truck after truck, the washing line components from Herbold Meckesheim start their journey to Kırklareli, Türkiye (All pictures: Herbold Meckesheim)*

*Like the entire PET recycling plant, the hydrocyclone stage for Doğa is designed for an output of 100 metric tons per day*



we know that we will realize the highest quality rPET flakes production in the most efficient way."

The special feature of Herbold's latest recycling plant is that it also supplies key components for pre-sorting, such as a debaler EWS 45/160 BA or a drum bottle wash unit HWTS 180/750. In terms of space, this section alone accounts for half of the plant layout. The actual cleaning process obeys state-of-the-art technology and starts with two force feeding granulators SMS 80/160-F7-2 SB3, the biggest in the Herbold portfolio. The hot washing and hydrocyclone stages, as well as the subsequent air separators, were designed for the required throughput. And three step dryers of the HVST 150/150 size are installed in the plant to achieve maximum capacity with minimum fines formation. In addition, the recycling line is equipped with an elaborated process water treatment.



Ömer Ayvaci (right), Chairman of the Board of the Doğa Group, and Mustafa Ergin, who represents Herbold and Coperion in the region

and Herbold Meckesheim provide comprehensive and innovative overall solutions based on the complementary and aligned technologies of both companies. From mechanical processing, from size reduction, washing, separating, drying and agglomeration of plastics, through bulk material handling, feeding and extrusion, to compounding and pelletizing, the business unit covers the entire process and thus value chain. A global network of engineering sites and service locations ensures fast order fulfillment, installation and commissioning as well as competent and fast on-site service. Modern test centers for product development and customer trials round off the portfolio of Coperion's Recycling Business Unit.

Herbold Meckesheim has been part of Coperion's Recycling Business Unit since last year. Together, the Stuttgart-based machinery and plant manufacturer

Herbold Meckesheim GmbH  
Industriestr. 33, 74909 Meckesheim, Germany  
[www.herbold.com](http://www.herbold.com)

# Latest Version of Multi-Purpose Cast Film Line with New MDO Unit

*SML has set up the newest version of its multi-purpose cast film line in its Technology Centre. The line is universally applicable and features a number of technical innovations: Above all, a further-developed MDO unit.*

"Our new multi-purpose cast film line will not fail to impress even long-serving experts. The line has the technical capacity to fulfil almost every customer requirement in cast film production", Elias Mayrhofer, R&D Engineer at SML, comments with pride. The cast film line is ready for the production of CPP, CPE, Cast-PET, barrier, as well as for mono-oriented films. The application areas are comprehensive as well: They range from film for metallised and laminated standard food and non-food packaging to easy-to-recycle stand-up pouches of MOPE film and

further to label film, and also include technical products like cable insulations and easy-tear MOPP film. Despite its wide functional range, the line can be further optimised for the manufacturing of specialised products – assuring the highest efficiency and maximum quality.

## Coherent concept

"A central characteristic of all of our machinery is the coherent line concept that we continue to develop and optimise," Elias Mayrhofer states. This is underlined yet again by the modern and clear design of SML's multi-purpose cast film line, which offers the following technical features:

- Five extruders for the processing of PP, PE, PA, PET, EVOH, as well as adhesives
- A seven-layer variable geometry feedblock with the possibility of numerous different layer arrangements





- Die width 2,850 mm, with internal decking system two times 350 mm
- New MDO unit: maximum roll temperature of 160 °C, maximum stretching ratio 1:10 Horizontal sliding winder for up to 4 part bobbins

#### MDO unit for mono-materials

One key innovation featured in SML's latest cast film line is the MDO unit, that is also designed for the manufacturing of easy-to-recycle mono-material films such as MOPP, MOPE and MOPET. With this MDO unit, properties such as the film strength in the machine direction, stiffness and puncture resistance are increased even further, while the film thickness and elongation in the machine direction are significantly decreased.

SML has streamlined the whole MDO process: The clean and straightforward design makes operation comfortable and provides sufficient space for maintenance offering easy access.

#### New roller arrangement – tight stretching gap

One of the main technical features of SML's latest MDO version is the process-optimised roller-arrangement. The adjustment of the stretching gap takes place in a motorised fashion, making the operation and alterations for product changes quite simple. As the stretching rollers have a diameter of 220 mm, the stretching gap can be kept narrow in a range between 50 and 200 mm (free length of the film between the rollers). While the distances between the stretching rollers can be reduced to a few mm only. The positions of the nip rollers in the stretching area are adjustable too. This ensures an ideal stretching process of the film, independent of the defined stretching gap.

#### Comfortable settings with SML's new HMI

Finally, all the process parameters of the MDO unit are digitally recorded and can be comfortably set and adjusted with SML's new HMI.

SML's new multi-purpose cast film line is available to customers for trials and sample production. For Further information:

SML Maschinengesellschaft mbH  
Gewerbepark Ost 32, A-4846 Redlham, Austria  
Elias Mayrhofer, mel@sml.at,  
www.sml.at

# PET Bottles Design for Highly Carbonated Drinks

*Cherkasy Brewery Company (Ukraine), a producer of beer and soft drinks, has modernized its fleet of equipment to produce PET bottles and purchased a blow molding machine manufactured by PET Technologies. It is integrated into a complete filling line.*

#### The origin of the project

"We need a new blow molding machine as soon as possible!" the owner of the Cherkasy brewery company appealed to PET Technologies. "The output of our filling line is 12,000 bottles per hour," he continued.

The answer of PET Technologies was immediate: "We've got a solution for you!"

The characteristics of innovative automatic blow molding machine APF-Max 8 fully met all the requirements of beer and soft drinks manufacturer.

- Output matches with the production line;
- Quick integration with filling line of European production;
- Simple logic of operating equipment process.

The Cherkaske Beer brand was founded in the city of the same name



on the high right bank of the Dnipro, one of the major transboundary rivers of Europe. It has gone through a stormy path from a small craft production to an enterprise equipped with high-tech equipment. Thus, the term Cherkaske comes from the name of Ukrainian city Cherkasy, where the brewery company located.

Year 2010 became a new milestone in the development of the Cherkaske beer brand. The first batch of Kvitochka brand mineral water was produced at that time. The name of the brand Kvitochka is a diminutive of the Ukrainian word kvitka, which means flower. The range of products began to expand gradually and reached up to 160 types. It was complemented by sweet carbonated water with fruit flavors, invigorating energy drinks and refreshing lemonades.

Sweet with tart notes, natural and tonic - their taste has been familiar to us since childhood. What a pleasure we get, quenching our thirst with a chilled drink from an ergonomic PET bottle. The latter became the connecting link between the Cherkasy Brewery Company and PET Technologies.



### PET bottles manufacturing

At the beginning of 2023, a beverage and beer manufacturer from the Cherkasy city purchased an innovative automatic blow molding machine APF-Max 8. A few months later, the equipment was integrated into the filling line and put into operation in series.

Currently, it produces 4 formats of PET bottles from 500 ml to 2 liters with an improved design. PET Technologies was fully involved in its design, as the technological component is extremely important!

Beer and lemonades are highly carbonated drinks. The design of the bottles, which Cherkasy brewery company used before, did not always withstand it. During long-term storage, the container was deformed, despite its relatively high weight.

Thus, PET Technologies with over 20 years of experience in the field had to take into account a number of customer's priorities related to design:

- Reduce the weight alongside with adding decorative elements;
- Increase resistance to internal pressure;
- Achieve optimal distribution of material on a narrow neck of the bottle.

The following solution was found. Cherkasy brewery company received an improved set of 500 ml bottles, 1500 ml and 2000 ml, where soft drinks are filled in. Spikelets are

the main decorative element on the upper part of the bottle. The shape of 1000 ml bottle for beer became more technological. This results were achieved:

- The updated bottle withstands internal pressure by 15-20% more than the old one;
- The weight is reduced by 1-5 grams; depending on the design, 30 tons less PET material will be used;
- The configuration of the bottom part developed by PET Technologies is implemented: it reduces the weight and withstands higher internal pressure;
- The optimal material distribution is achieved due to the NIR heating system, which the automatic blowing machine APF-Max 8 is equipped with.

### Design advantages of the automatic blow molding machine APF-Max 8

A quick change of 8-cavity blowing molds on the machine, despite its large size, allows the Cherkassy Brewery company to manufacture a wide range of containers with minimal equipment downtime. Only 20 minutes are enough to switch from a 500ml bottle to a 2000ml bottle.

If it is necessary to switch from the PCO1881 bottle neck finish standard to another one in the future, it will be enough to stop the production line for 2 hours as maximum.



The automatic blow molding machine APF-Max 8 is equipped with 6 servo drives. They provide more accurate preform fixation during the high-speed operation, constant speed of the heater conveyor and stable bottle formation process.

The position of the stretching rods is automatically adjusted depending on the height of the bottle while changing from one bottle format to another. Pre-blowing is also controlled via PLC. The last one is placed outside the machine. Its location can

be chosen depending on the operator's preferences.

### Fruitful cooperation between companies

Cooperation between the Cherkasy Brewery Company and PET Technologies lasts for more than 10 years. It started from a rotary-type blow molds and moved to another stage: trust, exchange of experience and support when challenges come. Growth, new opportunities and innovations in production.

PET Technologies  
<https://pet-eu.com/>

# New INNOSORT™ FLAKE for Unrivaled Flake Sorting Performance

*TOMRA revolutionizes its product portfolio with the launch of the new INNOSORT™ FLAKE for high-throughput purification of plastic flakes. Its enhanced features enable simultaneous flake sorting by polymer, color and transparency achieving unmatched quality even from highly contaminated inputs.*

In the industry's quest to increase recycled content by producing post-consumer recyclates for high-end applications, TOMRA has leveraged its 50 years of experience in circular waste management and developed the next-generation flake sorting technology. With the introduction of the new INNOSORT™ FLAKE, TOMRA provides the ideal flake sorting solution to help the industry recover more recyclable materials from any waste stream with maximum yield.

Alberto Piovesan, Global Segment Manager Plastics at TOMRA Recycling Sorting, explains: "Given recycled content targets in Europe and elsewhere, the market needs to prepare for future demand. Recyclers need solutions to produce high-quality post-consumer recycled content in sufficient volumes. At the same time, they strive for reliable sorting results and operational flexibility. With the new INNOSORT™ FLAKE, this is now possible."

### Any color. Any polymer.

Equipped with a powerful sensor combination, the new INNOSORT™ FLAKE sorts polymers by material type



The new INNOSORT™ FLAKE

and color, removing any impurities to create pure fractions. Thanks to its advanced near-infrared (NIR) spectrometer, the machine precisely detects various polymers, allowing for the recovery of recyclable materials from highly contaminated infeed. With this technology, plastics recovered from mixed waste, for example, can be sorted for recycling, giving access to more recyclable materials that otherwise would be lost or downcycled for lower-grade applications. For instance, polyolefins (PO), such as polyethylene (PE) and polypropylene (PP), are often found comingled in the same waste stream. With the new INNOSORT™ FLAKE, mixed plastic fractions that have been shredded and washed can be sorted into clean fractions of PET, PP and PE and other materials that meet the quality requirements for extrusion and the creation of high-quality post-consumer recycled (PCR) content.

Moreover, plant operators profit from the machine's unmatched color sorting performance. Its enhanced optics, with a changeable color background and dual-sided high-resolution cameras, detect millions of colors and create single-color fractions. Its high contrast imaging can even differentiate between white opaque and natural, transparent and translucent flakes, reducing material losses and maximizing yield.

Piovesan adds: "The new INNOSORT™ FLAKE is designed to sort any color, any polymer, at the same time. It levels the playing field for recyclers and gives them maximum flexibility to respond to the respective market demands. If an operator wants to purify PET this month and produce a clean blue PP next month, it is technically possible with the new machine. What's more, it is cost-effective."

### New design with multiple benefits

William Zeng, Product Manager TOMRA Recycling Sorting, describes: "We developed the machine with the requirements of our customers in mind. With its integrated cooling system and robustness, it delivers an even more stable performance in challenging environments and delivers reliable results for maximum output and profitability. Furthermore, with the enhanced technologies, recyclers already achieve very high purity

User interface new INNOSORT™ FLAKE



Polyolefin flake sorting

levels after the first sorting step. Depending on the contamination level of the input material and the target purities, fewer sorting steps might be required."

The new INNOSORT™ FLAKE comes with up to four chutes and a changeable illumination background. This level of flexibility makes it possible to run multiple sorting and recovery steps in a single machine, leading to considerable time savings and less material handling.

As a system only performs best when all components work seamlessly together, maintenance is crucial. The new design gives unrestricted access to the machine's components enabling smooth maintenance with little downtime.

### Data-driven analysis

In addition, TOMRA Insight can be installed as an add-on service. The cloud-based data monitoring platform contributes to improving sorting performance. On the one hand, it helps optimize processes through data analysis. Identified inefficiencies and predicted maintenance further support the reduction of machine downtime and productivity losses. On the other hand, its real-time monitoring gives plant operators access to data anywhere and anytime to maintain process stability.

Piovesan concludes: "Thanks to the enhanced technologies, the new INNOSORT™ FLAKE revolutionizes plastic recycling. Customers testing our system are convinced of its capabilities and ease of use. Now, they can mitigate higher levels of contamination and create the highest purity fractions by running multiple sorting steps simultaneously. This adaptability combined with state-of-the-art technologies makes the new INNOSORT™ FLAKE a future-proof flake sorting solution for any recycler who aims to produce extrusion-ready flakes."

# Pellet Vision – *Constant Pellet Quality – Forever!*

*The technology leader in underwater pelletizing has been regularly providing innovative advances in the industry for decades. This time, the focus was on process stability through intelligent systems. Pellet Vision is a system for evaluating pellet quality that has already been proven on the market under production conditions. Shape deviations can be detected immediately and corrective measures can be taken. The gain in stability and cost reduction can also be retrofitted on existing systems.*

## *An Interview with C-level management of the ECON group*



*Gerhard Hehenberger*  
(CEO)



*Dominik Neumann*  
(Head of R&D)



*Stefan Schedlik*  
(CTO)



*Gerhard Hemetsberger*  
(CSO)

### **What was the development approach for the Pellet Vision?**

**Gerhard Hehenberger (CEO):** Customer-oriented innovation is ECON's top priority. With the first presentation of the Pellet Vision in 2019, we already emphasized our visionary approach towards automatic and self-optimizing underwater pelletizing (UWP) several years ago. In the meantime, we have further developed the system to series production readiness and it is already being used very successfully by some customers.

### **Can you explain the operating principle in a few words?**

**Dominik Neumann (Head of R&D):** Simply put, the pellets produced are matched with the shape and size of the target pellets. However, since no suitable software is available on the market for our purposes, we have developed software and algorithms for evaluating

the pellet quality ourselves. In detail, this means that the shape and size of the pellets in the production process are randomly compared (e.g. every 10 min) with a target pellet. Deviations are detected statistically and then a warning and visualization are transmitted to any interface (HMI of the UWP, HMI of the extruder, at the process control station, etc).

### **What customer benefits does the system offer?**

**Stefan Schedlik (CTO):** By detecting changes in pellet geometry early, our customers achieve a stable and consistent pellet quality while minimizing off-spec material. Since Pellet Vision also detects the cause of changes, such as process fluctuations in the upstream area, the machine operator can intervene in a targeted and time-saving manner. In the direction of fully automated systems, personal sampling is also no longer necessary. Incidentally, the Pellet Vision can also be retrofitted on existing systems.

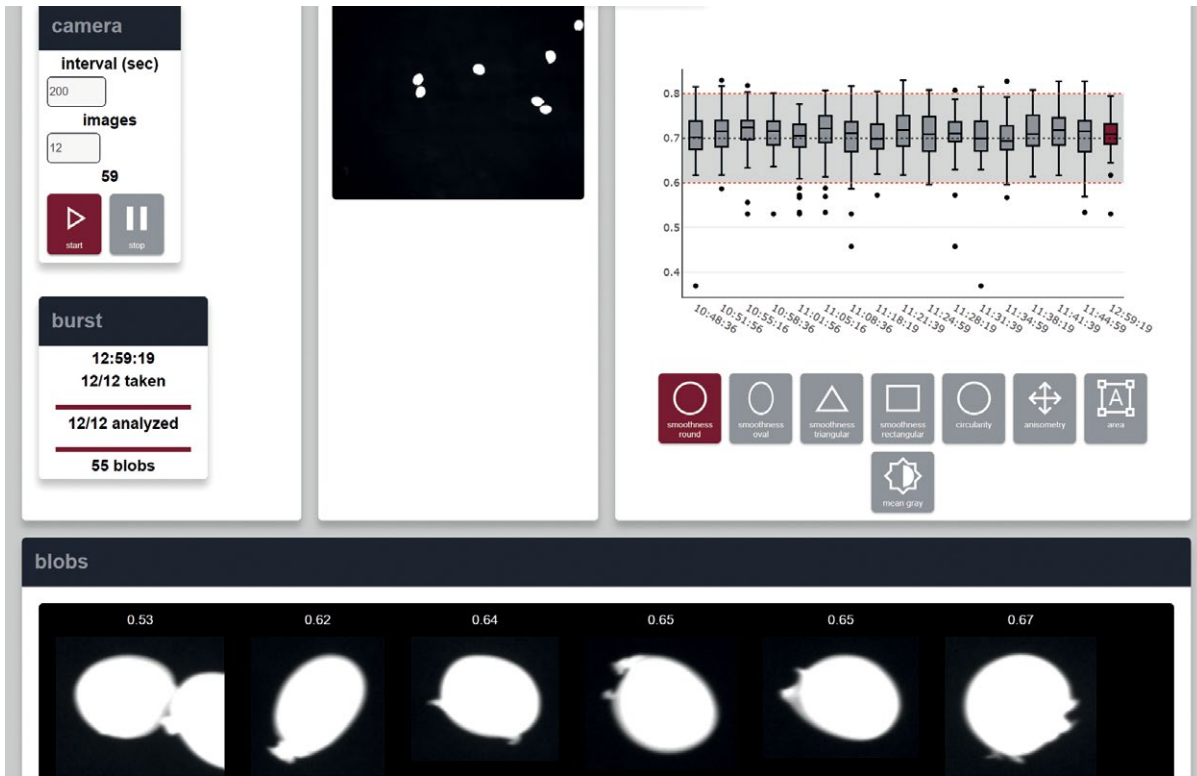

**What does the future hold for ECON?**

**Gerhard Hemetsberger (CSO):** The highly gratifying feedback from our customers motivates us to continue to develop the Pellet Vision into a fully automatic self-optimization of the UWP. The machine thus controls and optimizes itself, with pellet deviations being corrected independently by adjusting process parameters such as speed, contact pressure, temperatures, etc.

Regardless of the future direction of our customers, ECON is already well positioned with our portfolio of manually operated and intelligent systems.

*Thank you for this interview.*

ECON GmbH  
 Biergasse 9, 4616 Weißkirchen, Österreich  
[www.econ.eu](http://www.econ.eu)

ECON



Air Pelletizing Systems, **ELG**



Pyrolysis Furnace, **EPO**



Underwater Pelletizing Systems, **EUP**



Water & Air Pelletizing Systems, **EWA**



Continuous Screen Changer with backflush system, **ESK B**

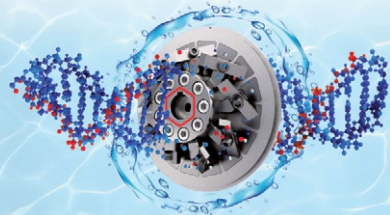

PELLETIZING IS IN OUR DNA

[www.econ.eu](http://www.econ.eu)

# Going with the Trend – *Shiny Detection Module Excels in Inspecting Vehicle Trims in Chrome and Trendy Black*

*Whether the classical chrome look or the new, trendy black: The new Shiny Detection inline module from PIXARGUS is a perfect solution to detecting scratches and bubbles on the challenging high-gloss surfaces of vehicle trims. Used in conjunction with the PIXARGUS ProfilControl 7 Surface system, this innovative inspection module helps producers minimize their scrap rates and production costs. A renowned Canadian automotive supplier has been using the reliable and efficient PIXARGUS technology made in Germany for many years.*

Called Shadowline, Black Edition or Night Package, the new exterior design packages in glossy or matt black offered by automakers render modernity and style. Moreover, they provide great flexibility for customization and are very much on trend. At the same time, the love for high-gloss chrome finish that gives a car a stylish, luxury look is unbroken. However, these eye-catching design elements also have a less shiny side: They are highly sensitive to physical impact and difficult to inspect due their high light reflectance and their complex shape. "The bar in quality inspection of these products is very high," says Michael Frohn, Sales Manager at PIXARGUS. "Even the smallest defects – hardly visible to the naked eye - are not tolerated."

**ProfilControl 7 S Shiny Detection:  
100% defect detection inimizizes  
scrap and costs**

The Shiny Detection module developed by measuring technology expert PIXARGUS ensures 100% defect detection on high-reflectance surfaces. The specially developed software of the module is able to even detect dark defects on glossy or matte black surfaces. "We have more than twenty years



*Black and high-gloss chrome trims may give objects a dazzling appearance in the true sense of the word. However, the extremely intensive light reflection makes it very difficult – not only for the human eye – to discern defects on the shiny surface (Photo ©Adobe Stock)*

of experience in automotive profile inspection. Throughout this time, we have continuously further developed and optimized our detection and quality control algorithms," adds Frohn. The measuring system expert is convinced: "Our inspection systems help minimize out-of-spec production and avoid complaints."

**From Würselen/Germany  
to Canada**

The PIXARGUS system is already successfully in use at a leading automotive supplier in Canada. The specialist in vehicle exteriors and design elements with premium finishes has been using technology from PIXARGUS in surface inspec-



*The PIXARGUS Shiny Detection module casts a pattern of structured light onto the high-gloss surfaces of the profiles to be inspected. These light patterns showing on the surface of the profile allow even extremely small scratches, bubbles or dents to be reliably detected (Photo ©PIXARGUS)*



**The functional principle – structured light and smart software**

The PIXARGUS Shiny Detection module casts a pattern of structured light onto the high-gloss surfaces of the profiles to be inspected. These light patterns showing on the surface of the profile suppress reflection while creating transitions of brightness that allow even extremely small scratches, bubbles or dents to be reliably detected. The system follows the exact contour of the product and inspects it across its entire width. The field of vision can be modulated to also ensure inspection of the curved areas of metal trims.

**Inspecting in parallel – inline and at any time**

PIXARGUS developed this inspection tool as an add-on module to

*Whether the classical chrome look or the new, trendy black: The new Shiny Detection inline module from PIXARGUS is the perfect solution to detecting scratches and bubbles on the challenging high-gloss surfaces of vehicle trims (Photo ©PIXARGUS)*

its ProfilControl 7 system. Shiny Detection can be flexibly switched in whenever necessary to inspect glossy products or products that are glossy in certain areas. A unique solution that makes it possible to also inspect products with surfaces that consist of different materials, e.g. chrome, foil or rubber, in one parallel process and at high line speeds. Thus, the new add-on module for glossy surfaces saves time and money.

tion of vehicle trim products since 2008. At its facilities in Canada the company operates eight PIXARGUS systems to check the quality of their products. For a recent investment in new quality control technology, the supplier again decided in favor of a PIXARGUS ProfilControl 7 Surface Shiny Detection system. “The system identifies even the tiniest of flaws in real time,” says PIXARGUS Sales Manager Frohn. He knows: “The system helps our customer to take measures to optimize the out-of-spec rate and minimize the scrap costs as a result.”

**Pixargus GmbH**  
 Industriepark Aachener Kreuz, Monnetstr.  
 2, 52146 Würselen, Germany  
 ► [www.pixargus.de](http://www.pixargus.de)

# Inline Thickness Measurement as a Success Factor in Plastic Film and Sheet Extrusion



KAPA – measuring frame

*Rising energy and raw material prices, issues related to personnel recruitment, and increased customer quality and traceability demands pose significant challenges for most extrusion operations in their daily production routines. The quality of products is defined, among other factors, by uniform properties across the width (flatness with tight thickness tolerances) and surface quality (free from defects).*

However, the efficient operation of an extrusion line is made possible by the interaction of numerous factors, as well as the design and condition of the equipment components. Notably, the influence of the operating personnel also plays a crucial role. Inline thickness measurement is thus a vital quality verification tool for equipment operators and QC personnel.

## Inline Thickness Measurement

Inline thickness gauges primarily provide quality control visibility during ongoing production by continuously displaying the cross-sheet thickness profile of the produced film or sheet. This provides immediate recommendations to the operating personnel for achieving the tightest possible product tolerances and minimal raw material usage.

Since the operating personnel have other tasks besides constantly monitoring the thickness profile, intervention typically occurs only when the gauge raises an alarm. Alternatively, with the option of Automatic Profile Control (APC), in conjunction with automatic dies, these systems automatically regulate the thickness profile deviation ensuring it stays within preset control lim-

its, thereby ensuring a flat thickness profile of the films/sheets. This aids in producing consistent, high-quality product with minimal waste and faster startups and product changes.

Moreover, thickness-optimized films enhance the efficiency of subsequent processing. The setup process, for example, in thermoforming systems and their production speed, depends significantly on the thickness profile of the film. The same applies to printing, converting, and other processing methods and refinements.

## Visualization

Picture 1 exemplifies the visualization of a thickness gauge HMI. The upper portion displays the thickness profile, and below it is a bolt status diagram, correlated with the lip adjustment bolts on the flat die. It is fundamental to optimize raw material usage during production and ensure the quality and usability of the product at all processing steps.

The operating personnel can immediately identify, based on the bolt diagram, which bolts need adjustment to maintain the required tolerances. This is especially valuable during startup and material/product



changes (width and/or thickness adjustments), saving valuable production time and reducing scrap material.

Setting target values is straightforward through the touchscreen on the HMI. Additionally, an included data analytics software package ensures a seamless recording of production parameters, such as production speeds, length, longitudinal and transverse profiles, average values, and trends. Comprehensive analysis tools provide insights into the operational state (efficiency) of the system.

The often-underestimated savings potential through the use of inline thickness gauges is illustrated in Picture 2. The table overview includes system parameters, exemplary for a PP thermoforming application, production costs, and the variance of the thickness profile (and achievable optimization through thickness measurement) as variable data. The program calculates annual material- and cost savings based on the achieved optimization.

Practice shows that even with very small optimizations in the micron range, annual savings are considerable, and the return on investment of thickness measurement can be achieved well within one year.

### A comprehensive Program

The Austrian company SBI Mechatronik and its global distribution network, covers various areas with its comprehensive range of measurement technologies, including sheet for thermoforming applications, conductive and foamed films and sheets, cast and stretch films, as well as EVA films for solar panels and coating applications. The company relies on the noted intelligent sensor and software technologies instead of radiation devices.

### From thermoforming sheets to landfill liners

The globally successful KAPA system for films and sheets up to 3 mm (118 mils) thickness [in an extended version up to 6 mm (236 mils)] uses a combination sensor capacitive/eddy current and creates a thickness profile with a repeatability of +/- 0.5 µm (0.02 mil). Applications of this highly reliable and contactless measuring meth-

Picture 1: Visualization

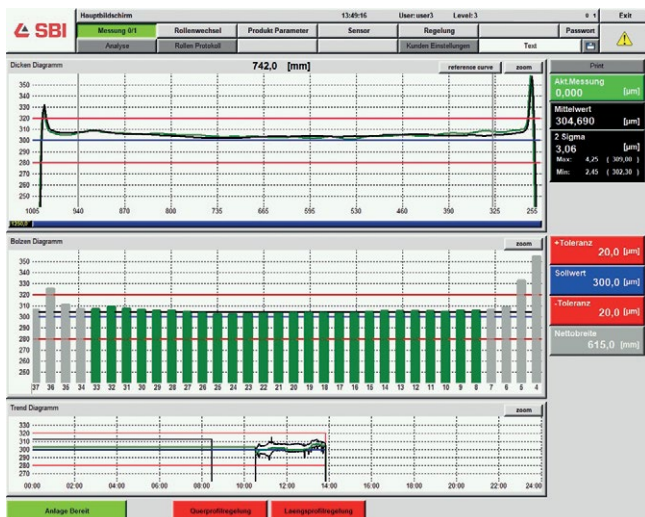

### Payback analysis SBI - thickness gauges



The yellow highlighted boxes are values to input.  
The white boxes are the results based on the inputs.

Input Parameters		
Production Details		
Working Hours	hrs	24
No. of working days/ year	days/yr	200
Machine output	kg/hr	600
Target Thickness of Production	micron	1000
Width of the film	mm	950
Density of Polymer	g/cm <sup>3</sup>	0,92
Line speed of the machine	mpm	11

Variation Parameters		
Average thickness variation observed without thickness measurement system	%	6
Average variation achieved with thickness measurement system	%	4

Production Recipe		
Polymer	%	96%
Additive 1	%	4%
Additive 2	%	0%
Cost of Polymer/kg	USD	€ 1,02
Cost of Additive 1/kg	USD	€ 2,00
Cost of Additive 2/kg	USD	€ -
<b>Cost of Production Recipe / kg</b>	<b>USD</b>	<b>€ 1,06</b>

Return On Investment Analysis		
Target Production Thickness	micron	1000
Average Thickness achieved without thickness measurement system	micron	1060
Average Thickness achieved with gauging system	micron	1040
Excess thickness produced without gauging system	micron	20,00
Raw material saving due to thickness measurement system	g/m	17,48
Total annual Raw material saving per year according to production capacity	kg/yr	57600
<b>Total Monetary benefit per year</b>	<b>USD</b>	<b>61 009,92</b>

Picture 2: Payback analysis

od range from thermoforming films and sheets (PET, PP, HIPS, etc.) to 8.5 m (27.9 ft) wide geomembrane films for tunnel linings and landfill seals.

### Direct measurement for foam films and others

For foamed films and sheets, as well as conductive materials up to a thickness of 3.5 mm (138 mils) (in a special version up to 8.5 mm (335 mils)), the SHADOW laser system is ideal. This direct measuring method uses a laser shadow/eddy current sensor and is manufactured up to maximum widths of 8 m (26 ft).

### Cast films

For thin-walled films (cast & stretch film) up to approximately 500 µm (19.7 mils), SBI offers a Soft X-Ray device, which measures the thickness and basis weight.



Picture 3: X-Ray System

Due to low output voltage ( $< 5\text{kV}$ ), XRS does not require licensing in most countries, leading to easy installation and maintenance. Picture 3 shows the application in a PP thin film extrusion.

### Heavy Gauge Sheets

The product range is completed by the STG system, specifically designed for thick rigid sheets up to 40 mm (1575 mils) thickness (and beyond if needed). Picture 4 shows an application in the production of HDPE sheet, where measurement is done using laser distance sensors. The maximum width is 3 meters (9.8 ft). The STG is a non-nuclear technology that does not require licensing or protection guards.

Common to all types of systems is the highest accuracy, reliability, easy handling, and operation of the

Picture 4: STG for rigid sheets

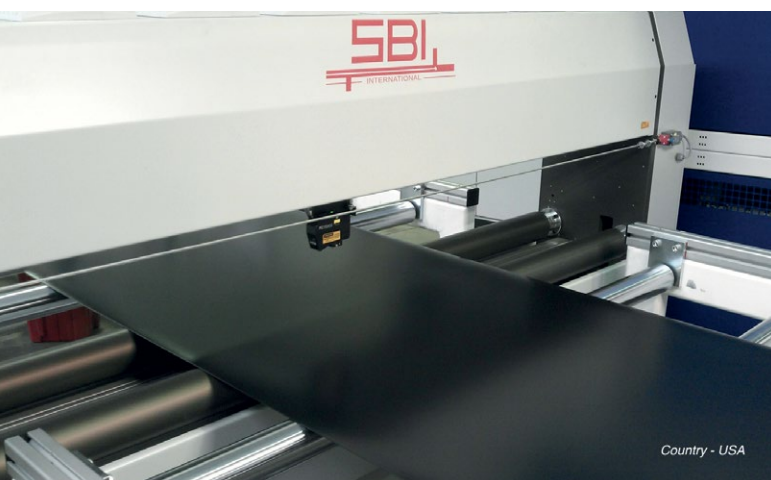

Country - USA

equipment. Installation and commissioning are quickly achievable, and maintenance requirements are low. Operating personnel appreciate the straightforward software and clarity.

### Conclusion

The integration of inline thickness gauges in extrusion systems represents a crucial step towards quality control, raw material savings, and production optimization. Precise monitoring of the thickness profile enables not only the adherence to the highest quality standards (avoidance of error sources) but also offers economic benefits (cost savings) through efficient production processes (relief of operating personnel) and minimized raw material consumption. Furthermore, the efficiency of processing films and sheets (thermoforming, printing, etc.) into end products is significantly increased.

### Factbox

*SBI Mechatronik GmbH, based outside Vienna in Hollabrunn, Austria, has been dedicated to the development, manufacturing, and international marketing of high-quality measurement and control systems for the plastic extrusion industry and other high-tech applications for over 20 years. Multiple measurement technologies and extensive software packages are available for real-time monitoring, measurement, and control of thickness uniformity and die configuration. This ensures optimal production conditions and high-cost efficiency.*

*Additionally, SBI's line of Web Inspection Systems is available in conjunction with a thickness gauge or separately to detect and flag product defects and to classify and report on them in a web roll report.*

*SBI systems can be found on all continents, with over 1,000 devices installed worldwide. Long-standing business relationships exist with extrusion machine manufacturers (OEM) as well as a variety of end-users, from film and sheet producers to large internationally active packaging manufacturers.*

*Comprehensive service, SBI service technicians are practically available around the clock, along with rapid spare parts supply, completing the range of services.*

SBI Mechatronik GmbH

Kaplanstr. 12, 2020 Hollabrunn, Austria

➔ [www.sbi-mechatronik.com](http://www.sbi-mechatronik.com), [office@sbi-mechatronik.com](mailto:office@sbi-mechatronik.com)

SBI Mechatronik GmbH is represented in North America by:

ARJ Auxiliary Equipment, LLC

c/o Vincent Harris

P.O. Box 47052, Baltimore, MD 21244, USA

Phone: +1.410.499.1559, Email: [vince@arjaux.net](mailto:vince@arjaux.net)

# Chinaplas

A Brighter and Shared Future, Powered by Innovation.



**Shanghai**

National Exhibition & Convention Center, PR China

**2024**

**4-23  
/  
4-26**



Hong Kong (852) 2811 8897 | Singapore (65) 6631 8955 | (852) 6217 0885

Chinaplas.PR@adsale.com.hk | www.adsale.com.hk | www.ChinaplasOnline.com



Pre-Register Now

Organizer



Co-organizer



Sponsor



Official Online Media



# EXTRUSION

EXPERT MAGAZINE ON PLASTICS EXTRUSION

The only technical magazine worldwide exclusively for the sectors:

- Material Preparation
- Compounding
- Extrusion
- Recycling
- Calendering
- Thermoforming
- Welding
- Finishing of Plastics and Elastomers



**Extrusion** (German)

**Extrusion International** (English)

**Extrusion International USA** (English)

**Extrusion Asia Edition** (Mandarin/English)

The only plastics trade magazine for Asia, published from Germany

8 issues a year

6 issues a year

6 issues a year

2 issues a year

**SMART  
EXTRUSION**

All editions available for free:

[www.smart-extrusion.com](http://www.smart-extrusion.com)

**VM Verlag GmbH** Cologne/Germany

