

EXTRUSION

INTERNATIONAL

ONLINE

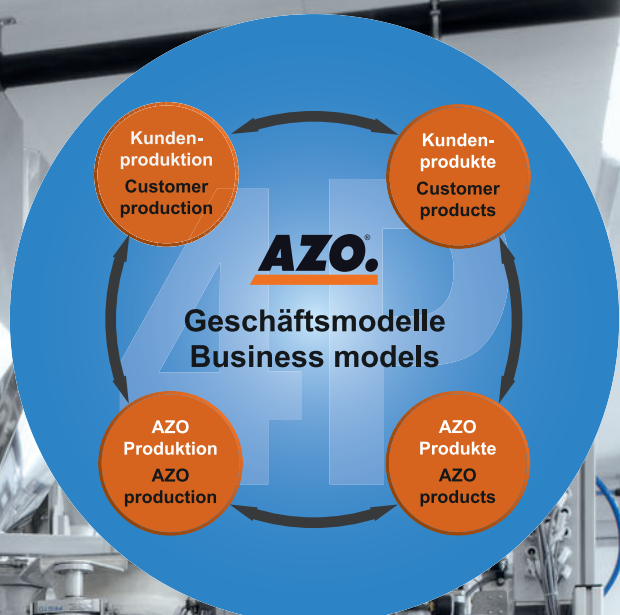

p. 18
Compounding 4.0

The NEW generation of cutters for profiles



- Mirrored changing of the cutter angle during running production
- For optimised cutting of the respective profile
- Changing within 10 to 15 seconds, between two cuts
- Without loosening screws, by hand, with pneumatic clamping device using two retaining cylinders
- Sensational price thanks to increasing demand and manufacturing in large quantities

The cutter was manufactured for the first time in 1998 and in constant use throughout the world. They offer the absolute best cutting quality for glass strips, small profiles, main profiles and technical profiles.

Additional devices such as automatic film wrapping, measurement wheels for precise length determination or lettering with inkjet or laser printers can be attached.

PTW-200 changeable cutting angle

Cutting Unit

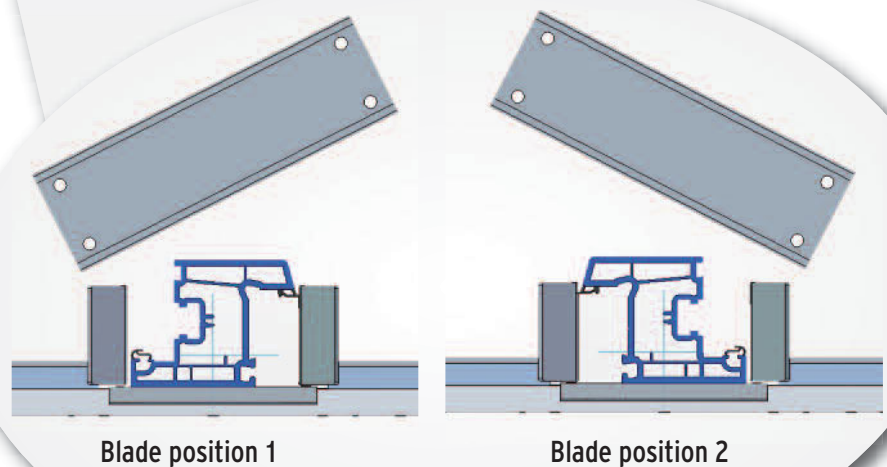
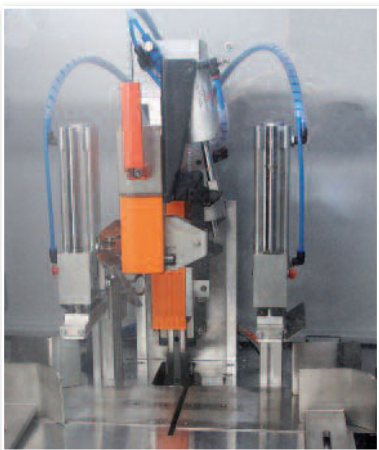

Hall 16
Stand F06



Made in
Germany

EQUIPMENT FOR EXTRUSION



FOR PROFILE EXTRUSION LINES



Calibration table KTS 01,
rear

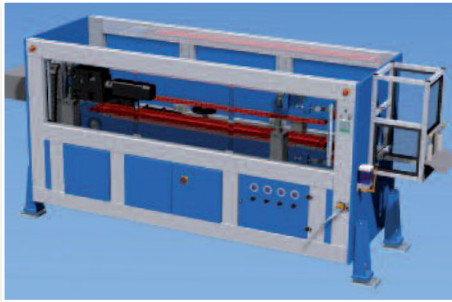

Caterpillar
Haul off

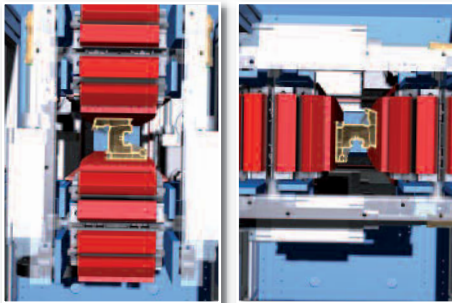

Haul off
rotating 90°



PRO 63
automatic stacker

FOR SHEET EXTRUSION LINES

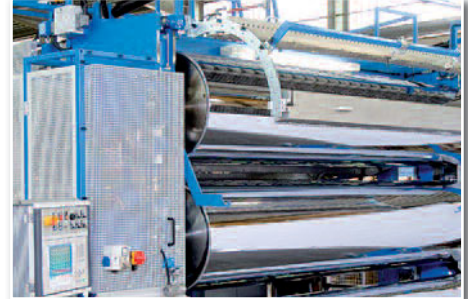

Calender



Roller withdrawal AZ 8,
outlet side



Slitting RB 2 with four
sawing stations



Transverse separating
cutter QSS, inlet

„STEIN BLUE-LINE – for a sustainable future“
stands for sustainable and energy-efficient equipment.
Almost 100% domestic production and the high degree
of manufacturing penetration guarantee compliance with
even the most stringent of demands.

**STEIN Maschinenbau
GmbH&Co.KG**

Wartbachstr. 9
D-66999 Hinterweidenthal/Germany
Tel. +49/63 96/92 15-0
Fax +49/63 96/92 15-25
stein@stein-maschinenbau.de ·
www.stein-maschinenbau.de

CONTENT



The ScrewCon configuration software developed by KraussMaffei for screw and housing elements of twin-screw extruders has proven its excellence for over twenty years. The latest 3.0 version of this program comes with a completely new user interface with numerous innovative features. ScrewCon is now also available for use by our customers.

Page 22

Firms in this issue	6	Premiere for new raw material	14
Imprint	7	Borealis acquires German recyclers	14
Industry News	8	Mtm plastics and mtm compact High-class coextrusion lines at a reasonable price	16
Strategies, figures and innovations	8	Global Advantage at K2016	16
Resource conservation with Bio-Flex FX	11	Maag Opens First Sales and Service Center in India	17
Zwick Roell opens training center	11	Compounding 4.0	18
ST Blow Moulding and DuPont consolidate their partnership	12	Configuring in next to no time	22
Composites Germany Pavilion to make 1st debut	12		

Reifenhäuser Blown Film hosted an Open House in Troisdorf during the DRUPA trade show held in Düsseldorf. A multitude of customers from around the world attended the event to learn about new opportunities in the application of film extrusion technologies.

Page 26





The manufacturer of machines and plants from Meckesheim/Germany was presented at IFAT 2016 in Munich new solutions for washing, separating and drying of plastic waste featuring low operating costs and higher efficiency. In the front of the line is the HERBOLD wet shredder HGM: beginning at the pre-size reduction step water is added, which is new. Until recently, water was only used in the granulation process where further size reduction occurred.

Page 36

Lower melt temperature, less energy consumption and cost reduction	24	Blessing and risk – X-ray radiation	32	Tradition Forms Future	34
Open House at the Extrusioners	26			Post – consumer recycling – More efficient and economic	36
Increased Flexibility and Food Contact Certification	27			Global premiere of XTREME RENEW at the EREMA Discovery Day 2016	38
„The ideal system for all requirements“	28			Plenty of potential for recycling	40
Extruded Pipe and Hoses Under Tight Control	30				

At this year's plastics trade fair, battefeld-cincinnati will be introducing a newly developed series of high-performance single screw extruders: the soLEX NG (NG = Next Generation) series. Developed on the basis of the proven soLEX series, this new generation features a completely new processing unit which offers a multitude of advantages, such as a lower melt temperature and energy costs reduced by up to 15%.

Page 24





Extrusion line for filament

Extruder 30 mm

Compounder RZE 85-40d

Extruders & Extrusion facilities

in stock • functionally tested • operational

This machines (and much more) are **immediately available** from our warehouse!

You are welcome for inspection, we are open for your requirements and our whole experience is at your service.

Open House during the K 2016



Plastic-Maschinen-Handelsges. mbH
Broichhausener Str. 4 · D-53773 Hennef
Tel. +49-2244-83041 · Fax +49-2244-83045

Visit our homepage
with many used machines for the
plastic extrusion business:
www.pmh-extruder.com

eMail:
pmh.gmbh@t-online.de

Index of Advertisers and companies referred in this issue

AZO	Frontpage+18	KraussMaffei	15+22
Aleko Machinery	16	maag	17+23
battenfeld-cincinnati	24	Messe Düsseldorf	40
Borealis Group	14	motan-colortronic	7
Brüeckner	8	mtm plastics	14
Composites Europe	12	pmh	6
Conextru	17	Reifenhäuser	26+28
Covestro	14	Reifenhäuser Blown Film	26
Davis-Standard	16	Reimotec	28
EREMA	28+38	S.T. SOFFIAGGIO TECNICA	12
Fimic	29	Sikora	32
FKuR	11	Stein	U2+3
Gneuss	27	Weber	9+10
Herbold	36	Zumbach	13
ILLIG	33+34	Zwick Roell	11
KOMAX	25		



The Extrusion International Digital/Print Magazine is published bimonthly by VM Verlag GmbH. P.O.Box 410907, D-50869, Cologne, Germany

EDITORS

Alla Kravets (Project Manager, Digital Content)
Tel.: +49 2233 3909090
a.kravets@vm-verlag.com

Bettina Jopp-Witt (Content Coordinator)
Tel.: +49 221 5461539
redaktion@vm-verlag.com

Yury Kravets (Managing Editor)
y.kravets@vm-verlag.com

ADVERTISING SALES

Inge Boehle (Sales Director)
Tel.: +49 721 700626
i.boehle@vm-verlag.com

Martina Lerner
Tel.: +49 6226 971515
lerner-media@t-online.de

Elena Beckmann
Tel: +49 0511 52487810
e.beckmann@vm-verlag.com

Reprints, Translation etc

No part of this publication may be reproduced, stored in a retrieval system, or transmitted, in any form or by any means, electronic, mechanical, photographic, recording or otherwise, without prior permission of the publisher.

www.extrusion-info.com

www.plastic.expert



FOR THE SMALLEST TO THE LARGEST VOLUME

 think materials management

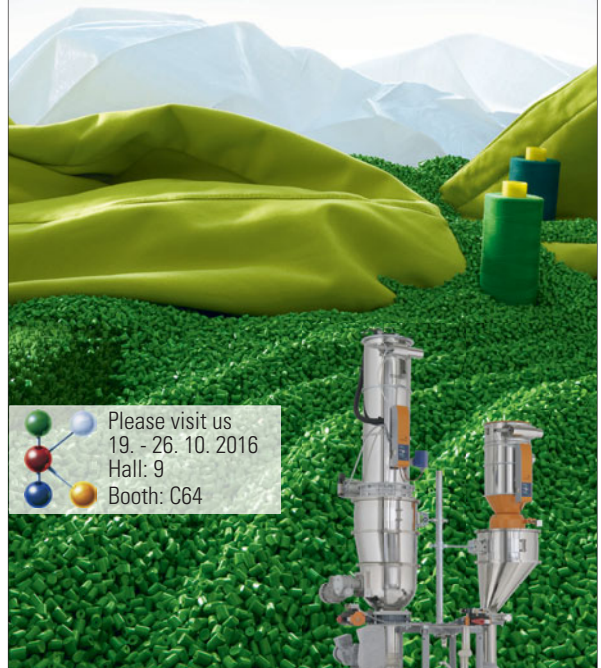

 Please visit us
19. - 26. 10. 2016
Hall: 9
Booth: C64

GRAVIPLUS

Ideal for any throughput

Hassle-free consistent dosing. 250 grams or seven and a half tonnes an hour, GRAVIPLUS delivers high-precision blending and dosing for any volume – whether it's granulate, powder or liquid. Benefit from accurate, high-quality and consistent dosing for complex gravimetric continuous processes – with GRAVIPLUS from motan-colortronic.



motan-colortronic gmbh
info@motan-colortronic.de

www.motan-colortronic.com





**4.VDI-Fachkonferenz
Additive Manufacturing**

06.07-07.09.2016

Duisburg/Germany

► VDI Wissensforum

www.vdi-wissensforum.de/en/

**Technikforum: Flammschutz in
polymeren Werkstoffen**

20-21.09.2016

Mannheim/Germany

► VDI Wissensforum

www.vdi-wissensforum.de/en/

**12th China International Recycled
Polyester and PET Packaging
Conference & Exhibition**

21-23.09.2016

Shanghai/P.R.China

► www.ccfci.net

K2016

19-26.10.2016

Düsseldorf/Germany

► Messe Düsseldorf GmbH

www.k-online.de

**Kunststofftechnik für
Maschinenbauer**

16-17.11.2016

Lenzing/Wels/Austria

► Kunststoff-Cluster OÖ

www.kunststoff-cluster.at

**Linzer Polymer Extrusion und
Compounding Tagung**

01.12.2016

Linz/Austria

► Kunststoff-Cluster OÖ

www.kunststoff-cluster.at

Strategies, figures and innovations



■ 25 specialised journalists from all over the world as well as local journalists were recently guests in Siegsdorf and Freilassing. They were informed about strategies, business figures and about the individual companies' innovations to be presented at the K 2016 in October in Düsseldorf.

The strategic management holding Brückner Group presented their growth strategy through leadership in technology as well as acquisitions. The management made clear that the stability within the group is guaranteed by a good turnover development.

Brückner Maschinenbau announced that the demand for biaxial stretched packaging film is expected to grow continuously. At the K show the company will once again be presenting exciting innovations such as BOPP lines with higher efficiency, BOPET lines with unrivalled working widths, simultaneous BOPA lines with a higher yield and Intelligent Line Management for simplified line operation and optimal line availability.

Brückner Servtec, the service & upgrading specialists, introduced several new service offers: Complete upgrading packets for special products, turnkey relocation of complete production lines including modernisation or an extended chain and clip service.

Brückner Group's Swiss member PackSys Global, one of the world's leading packaging equipment manufacturers, presented what visitors to K 2016 will be able to see at their booth: 360° digital printing, new heading and capping systems, a new generation of tube packing machines and hot stamping on the latest equipment.

Group member Kiefel informed the press about the upcoming highlights: latest pressure forming machines for an efficient cup and domed lids production, a new space-saving benchtop filling module for infusion bags and the latest welding generator with pioneering semiconductor technology, both for the medical sector.

► www.brueckner.com

Pipe extrusion

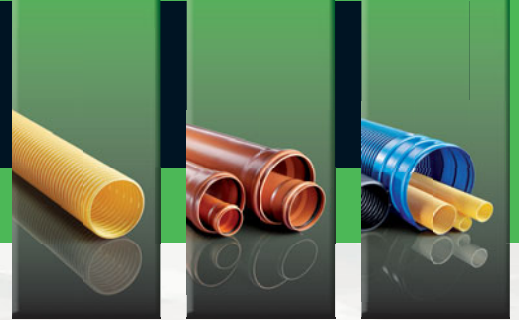

DS 9.32

The new DS 32 D series: Maximum performance for PVC pipe extrusion

WEBER
High Performance
DS 32 D Series

Once again WEBER set new standards in extrusion technology. The new extruder series DS 32 D, equipped with powerful drive technology and innovative screw technology, provides new impetus for PVC pipe manufacturing.

Advantages of the *High Performance* DS 32 D series

- Compact, robust gearbox technology in WEBER quality
- High outputs even with smaller L/D ratio's
- More flexible applications through larger range of output
- Easy processing of high content PVC plastics
- Improved product quality even when using recycling materials
- Processing of cold mixtures



www.hansweber.de

WEBER

Pipe extrusion

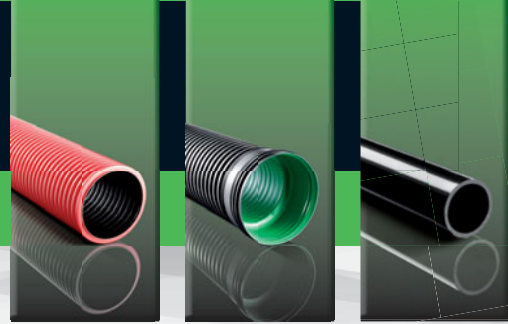

NE 7.40

The NE 40 D series: Maximum performance for polyolefin pipe extrusion



WEBER have been building grooved bush extruders for more than five decades. A unique *High Performance* range was developed especially for extrusion of HDPE and PP pipes.

Advantages of *High Performance* NE extruders

- Long effective life of grooved bush and processing unit through lower grooved bush pressure
- Constant output across the entire speed range
- Lower melt temperature compared to older machine concepts
- Output increase by up to 40 %
- Reduction of energy consumption
- Reduced water cooling of the grooved feed bush and new drive concept
- Torque motor optional



Hall 16
Stand F06



WEBER
GREEN
TECHNOLOGY

Hans Weber
Maschinenfabrik GmbH
Bamberger Straße 19 – 21
96317 Kronach · Germany
Post Box 18 62
96308 Kronach · Germany
Phone +49 (0) 9261 409-0
Fax +49 (0) 9261 409-199
info@hansweber.de
www.hansweber.de



Resource conservation with Bio-Flex® FX

■ The Bioplastic specialist FKUR has developed a new technology for the production of compounds which can be processed into flexible packaging films with particularly low thickness and, at the same time, high puncture resistance. With Bio-Flex® FX 1120 and Bio-Flex® FX 1130, FKUR will be presenting the first two products based on this new technology at the K 2016. Films made from these materials are suitable for food contact and compostable according to EN 13432. Depending upon the type, the proportion of renewable raw materials is more than 50%. The processing of both FX types of Bio-Flex® corresponds largely to standard PE processing.

For especially thin films

Bio-Flex® FX 1130 is designed to complement the previous standard compound Bio-Flex® F 1130. Whilst films made of conventional F 1130 have a paperlike touch the FX quality offers a silky surface. Films produced with this blend are further characterized by an increased tensile strength, puncture and tear resistance. This enables converters to use less material without compromising the performance characteristics of the film. In practice, it has been proven that film thicknesses of 8 microns are possible. In addition, film manufacturers benefit from high throughputs in extrusion, as well as excellent sealing properties of the material.

For 50% biobased bags

Bio-Flex® FX 1120 is a new development for film production, especially for very thin bags, such as bio-waste bags. The in-



Thin and puncture resistant compostable film bags are one of the main applications for the new FKUR FX series blends; © FKUR

creased water resistance, when compared to starch blends, permits a high retention of moisture which is originated during the decomposition of organic products in bio-bags. With a high proportion of renewable raw materials of more than 50%, the Bio-Flex® FX 1120 compound fulfills the requirements of the German Bio-waste Ordinance.

www.fkur.com
www.fkur-biobased.com

Zwick Roell opens training center

Opening Training Academy
by Dr. Jan Stefan Roell,
CEO of Zwick Roell AG



■ Testing machine manufacturer Zwick Roell, in collaboration with the aid organization Don Bosco Mondo e.V., opened the Zwick Roell Training Academy in Chennai, India, at the end of June. Disadvantaged youths will take part in a one-year training program here to become testing machine operators, easing their entry into working life and thereby giving them an opportunity for a better future. Beginning in the summer of 2016, the Zwick Roell Training Academy at the Don Bosco Tech Campus, located in the heart of one of Chennai's poorest districts, will train disadvantaged youths to become testing machine operators. Zwick Roell leased an empty hall here, which it then renovated and equipped with state-of-the-art materials testing machines. The equipment ranges from various static testing machines to hardness testing devices, a pendulum impact tester and a melt index testing instrument. Two instructors employed for the training program will qualify six to twelve young people to become materials testing machine operators each year. One training focus will be on testing metals and plastics. Zwick Roell will additionally use the laboratory for customer demonstrations and contract testing.

www.zwick.com

ST Blow Moulding and DuPont consolidate their partnership

■ On June 24th a major inaugural ceremony was held at the European Technical Center of DuPont in Meyrin, Geneva. The ceremony, marking the culmination of eight years of cooperation between the two companies, was attended by Pierre Maudet, Minister for Economy and Security for Geneva; Daniel Loeffler, Director at Economic Development Office for Geneva; Rolf Gobet, Director of the Office for the Promotion of Industries and Technologies (OPI); as well as members of the press.

The ceremony was held to inaugurate the launch of a new machine for the blow molding of plastics, model ST ASPI SECO that the company ST Blow Moulding, with a production site in Stabio, in the canton of Ticino, has recently delivered to the research center of Meyrin.

The Meyrin site is the technological research and development center of DuPont, a cutting-edge space in research and technical innovation. For over 20 years now, the European Technical Centre works for the development of applications, such as, for example, blow molding air ducts, based on a collaborative approach.

This is the second blow molding machine supplied by St Blow Moulding, after the first delivered in 2010, and confirms the strong partnership between the two companies.

The delivered blow moulding machine model ST ASPI SECO is suitable for the production of parts with materials in monolayer, coextrusion or SeCo (Sequential Coextrusion), in case of need to produce items requiring different mechanical or chemical properties in predefined areas, usually for the automotive industry.

The machine is equipped with two extruders of 60 mm, two accumulator heads, respectively by 1 and 1.5 liter and a co-extrusion head.



An application worth mentioning is definitely the 4WDS radial control system, integrated in this model of blow moulding machine.

This system, based entirely on the experience and technical knowledge of St Blow Moulding allows to obtain a uniform wall thickness, also for parts of more complex shape and difficult to be manufactured.

Furthermore, the ST ASPI SECO blow moulding machine is the only model of the ST ASPI range equipped with a shutter that allows a perfect control in the transition from one material to another, during the sequential production.

► www.st-blowmoulding.com

Composites Germany Pavilion to make its debut



Composites Germany



■ The industry association Composites Germany will host its first ever group stand at this year's COMPOSITES EUROPE (29 November – 1 December in Düsseldorf). The umbrella organisation of the German fibre-reinforced composites industry, whose members include the AVK, CCEv, CFK-Valley Stade and the VDMA Working Group Hybrid Lightweight Technologies, will host a 350-square-metre group stand featuring a total of 18 member companies.

The exhibitors at the Composites Germany Pavilion will include KraussMaffei Technologies, Dassault Systems Deutschland, Siemens, Olin Epoxy Stade, the Institute for Composite Materials and Leichtbau-Zentrum Sachsen GmbH. In all, some 350 exhibitors from 20 nations are expected at COMPOSITES EUROPE this year. The focus of the trade fair will be on technologies and trends from the glass-, carbon- and biofibre-reinforced plastics segments. Following on the heels of the huge success of the 1st International Composites Congress at the previous COMPOSITES EUROPE in Stuttgart, the industry association Composites Germany will once again host its next congress as the trade fair kick-off event, this time on 28 and 29 November 2016 in Düsseldorf. This year's partner country Japan will be represented by a number of exclusive speakers.

Taking place with the tagline "Composites – On the path to becoming a key industry", the congress will feature more than 30 international presenters exploring the latest trends and developments in the fibre-reinforced plastics/composites segment of the industry. New applications and technologies along with a comprehensive overview of market developments in Europe and worldwide will reveal that composites play a more and more significant role in light-weight engineering.

www.composites-germany.org
www.composites-europe.com

Get Your Extrusion Process Under Control

Based on decades of experience in on-line measuring solutions, developing key technologies and optimizing processes, ZUMBACH is YOUR partner!



- Best price-performance ratio in the market
- Faster start-ups / Scrap optimization
- Measure and adjust concentricity/eccentricity from the very first second regardless of the materials' temperature
- Investment recovered within a few months

Zumbach
SWISS PRIME MEASURING SINCE 1957

Visit us at:



Booth 10 / E41

Learn more about our unique solutions



ZUMBACH Electronics
sales@zumbach.ch | www.zumbach.com

Premiere for new raw material

■ Covestro is now, for the first time, using CO₂ to produce plastics on an industrial scale. On Friday, the company opened a production plant for an innovative foam component made with 20 percent CO₂ at its Dormagen site near Cologne, Germany. The new process saves a proportional amount of the traditional oil-based raw material, thus making a contribution to sustainability that Covestro believes offers considerable potential.

Covestro scientists worked hand-in-hand with experts from the CAT Catalytic Center in Aachen – a research institute operated jointly with RWTH – to find the right catalyst that would make the chemical reaction with CO₂ possible.

For mattresses and upholstery

In Dormagen, Covestro is now using carbon from CO₂ to manufacture a new type of polyol. These are core building



blocks for polyurethane foam – a versatile material that is used in many industries around the world and that we encounter throughout our daily lives. The carbon dioxide is chemically bound into the material.

The company has invested some EUR 15 million in the new plant, which has an annual production capacity of 5,000 metric tons. The CO₂ used is a waste product from a neighboring chemical company.

The new CO₂-based polyol has been engineered initially for flexible polyurethane foam intended for use in mattresses and upholstered furniture. In terms of quality, the foam achieves at least the same high standards as conventional material produced using only petrochemical raw materials, i.e. crude oil.

Environmentally friendly processes

By eliminating the use of crude oil and saving the energy otherwise used to process that oil, the method is more environmentally friendly than conventional production processes. Thanks to the catalyst and the considerable energy contained in the remaining content of petrochemical raw materials, no additional energy needs to be expended to make the low-reactivity CO₂ react.

If the new CO₂-based products are received as warmly as is hoped, Covestro can envisage significant production expansion. In addition to flexible foam, the company is also working on manufacturing many other plastics with carbon dioxide. Its vision is to one day largely dispense with crude oil in plastics production.

www.covestro.com

Borealis acquires German recyclers mtm plastics and mtm compact

■ Borealis, a leading provider of innovative solutions in the fields of polyolefins, base chemicals and fertilizers, announces today that it has fully acquired the German plastics recyclers mtm plastics GmbH and mtm compact GmbH. Based in Niedergebra, Germany, mtm plastics GmbH is regarded as a technology leader in the recycling of mixed post-consumer plastic waste and as one of Europe's largest producers of post-consumer polyolefin recyclates.

The sister companies mtm plastics GmbH and mtm compact GmbH will become members of the Borealis Group. The two Managing Directors will remain in their roles to ensure business continuity.

“Over the past decade, innovations are increasingly addressing sustainability issues and caused stakeholders to rethink and reshape their approach to value creation. As a leader in our industry, it is a part of our responsibility to be in the driving seat to couple growth ambitions with providing solutions to

solve society’s global challenges,” explains Alfred Stern, Borealis Executive Vice President Polyolefins and Innovation & Technology. “This is why we are fully committed to the principles of the circular economy and with this acquisition we now take our engagement to plastics recycling to the next level.” Borealis is committed to the principles of a circular economy and embraces polyolefins recycling as a strategic part of the business. Over the last years, Borealis has been actively advancing its recycling and sustainability efforts, including:



- Daplen™ post-consumer recycling (PCR) solutions, innovative high-quality PCR compounds for automotive applications.
- Design for recycling efforts, such as the „Full polyethylene (PE) laminate” to replace non-recyclable multilayer packaging and “Daploy™ high-melt-strength (HMS) polypropylene (PP) for improved recyclability.

www.borealisgroup.com
www.mtm-plastics.eu

Please visit us at K 2016:
hall 15, stand B27 / C24 / C27 / D24
October 19 - 26, 2016
Duesseldorf / Germany

www.kraussmaffeiberstorff.com

Next-generation compounding: The new ZE BluePower with maximum performance and enlarged volume!

The ZE BluePower series offers highly innovative and flexible solutions perfectly tailored to your specific compounding tasks. 30 % increase in torque density and 23 % more volume* - the ZE BluePower reaches a new premium efficiency class with 30 % higher output rate* at minimum energy input.

* As compared to previous generation extruders of identical size

Engineering Value

KraussMaffei
Berstorff

High-class coextrusion lines at a reasonable price

■ The Russian company Aleko Machinery is ready to offer to the global market high-class equipment at a reasonable price. Today, Aleko is the largest designer and manufacturer of multilayer coextrusion PE blown film lines with its own production facilities.

In the modern world, packaging has to meet the highest standards of quality and at the same time to have low cost in order to reduce the price of final product. This became possible thanks to new technical solutions in extrusion. Aleko company has created a machine, which makes it possible to produce more cost effective packaging while maintaining high technical characteristics of the film.

Aleko blown film extrusion lines allow to produce HDPE films with a high content of CaCO₃ filler (up to 70% into layer B) or up to 100% of recycled material. For example, at Aleko extrusion lines, our customers produce films with layer's ratio up to 1/8/1. To achieve this, we have designed screws with excellent mixing abilities, as we tend to adapt our lines for stable operation on raw materials of any quality. In this way multilayer coextrusion lines ABA type are especially popular among our clients.

At the K 2016 Fair in Düsseldorf (Booth 16D03) Aleko will present three layer blown film extrusion line Aleko ABA-110-45/55 in operation. Aleko equipment is notable for high performance along with low power consumption. For instance, the capacity of the ABA with the screws D=45/55 is up to 180 kg/h when working with LDPE, while power consumption is only 0,27 KW per 1 kg of product. And the extrusion lines ABC type with screws D=45/65/45 and D=55/65/55 produce up to 320 and 400 kg/h on LDPE.

Temperature difference is an extra power consumption. Therefore, we develop ourselves software for equipment control. The basis is self-learning system of PID control. This solution decreases the temperature difference and gives additional power economy.

Along with that, Aleko offers multilayer coextrusion lines from 5 up to 9 layers under joint brand name "Aleko-Alpha Marathon" in cooperation with a well-known Canadian company Alpha Marathon which is famous in the market as a manufacturer of nanolayer film extrusion, whose innovative engineering solutions allow to produce films with up to 77 nanolayers.

More than 20 years of experience in polymer industry, allowed us to accumulate necessary knowledge to feel confident in present and to create new trends in the future.

Aleko Machinery works so that clients are able to find perfect solution for packaging production.



en.polimerexpert.ru

Global Advantage™ at K 2016

■ Davis-Standard, LLC will exhibit the depth of its Global Advantage™ in extrusion and converting technology during K 2016 in Düsseldorf. Technology being shown includes examples of extruder, feedscrew, die, unwind, and control system advancements as well as the company's innovative dsX™ technology and extensive aftermarket capabilities. As an added benefit, Davis-Standard's team will host visitors at ER-WE-PA's Erkrath facility for equipment demonstrations. Following are highlights from Davis-Standard's K display:

Extruder with QSE Adapter – This 3.5-inch (90mm) extruder has preferred features such as computer designed feedscrews, electrical barrel heating with air-cooling for each zone, and simplified electrical installation. Mounted on the extruder will be a QSE (Quick Screw Exchange) adapter for fast screw changes without disturbing the downstream melt path.

High Speed Film & Foil Unwind – Designed for thin substrates, this two-position turret unwind is designed for an 800 meter-per-minute splice speed for sensitive webs such as aluminum foil at 6 μm. Unique splice

unit controls and safety standards create excellent reliability for high-speed splicing of complex webs.

Feedscrew and Die Displays – Davis-Standard is a global leader in feedscrews and die designs for improved processing efficiency. Multiple feedscrew designs and finishes will be shown in the booth at the K Show, as well as a seven-layer die stand from Davis-Standard's Gloucester Engineering product line. Also being promoted will be the new die rebuild services offered by Davis-Standard Limited in the United Kingdom.

dsX™ Technology – This popular line of extrusion coating, cast film and blown film equipment offers processors advantages in price, per-

formance and delivery. Each system is engineered for greater up-time, increased productivity and reduced waste, and backed by Davis-Standard's 24/7 global support network.

Aftermarket Capabilities – Davis-Standard's ability to service equipment for nearly every extrusion and converting application, including non Davis-Standard brands, is one of the company's greatest advantages. This includes an extensive spare parts inventory, timely 24/7 customer service, global technical capabilities, rebuild and retrofit services.

► www.davis-standard.com

Maag Opens First Sales and Service Center in India

■ Maag, a leading global manufacturer of gear pumps, pelletizing systems, filtration systems, and pulverizers, has announced the opening of its first sales and service center in India which includes a world-class rotor sharpening workshop for strand pelletizers. The opening of the new India service facility follows the recent expansion of Maag's sales and service center in Thailand.

The new rotor sharpening center in India will expand Maag's service footprint in Asia, which is one of the world's fastest-growing regions for plastics manufacturing and processing. It is the eighth rotor sharpening workshop for Maag, expanding the company's capabilities beyond Brazil, China, Germany, Malaysia, Taiwan, Thailand, and the U.S.

"This is a big step forward for Maag in Asia," said Thomas Willemssen, vice president of business development for After Sales and Service Centers. "We consider India as one of the most in-

teresting and fastest-growing markets and we decided to be proactive in serving our customers and the industry in India."

The new sharpening center in India, which opened August 1, is located in Vadodara (Gujarat). Maag made a significant investment in new state-of-the-art grinding equipment which makes the new center the most modern facility in India, according to Willemssen. In addition to high-quality grinding service for rotors, bed knives and die plates, Maag offers also short delivery times and service support through its qualified service technician for its customers.

Maag's rotor sharpening service can handle a broad range of standard rotors and bed knives which are used in plastics pelletizing. The 1000 m² production facility in Gujarat is large enough to accommodate future expansion plans, the company said. The India sales and service center employs about 6 people at the moment.

► www.maag.com

CONEXTRU ENGINEERING FOR EXTRUSION

You need a new tool for your new pipe product?

- quick and at low cost – specially made for your request
- in mono- or multi-layer or for coating in your current pipe production

You want to modify your existing tools to multilayer and for internal pipe cooling, to make a new product?

Then **CONEXTRU GmbH** is the partner for you – the most experienced company in pipe tool design.

The development of new tools for pipes is our profession and passion – for more than 25 years.

Compounding 4.0

Moving forward with AZO to the digital age with networked processes, a comprehensive information portal and the first Industry 4.0 components

Digitisation will rapidly lead to added value for the plastics and plastics-manufacturing industries. High time to take a systematic approach to tackling the potential offered by Industry 4.0 (or the Industrial Internet of Things) – to follow the example set by AZO, the plant engineering company. The result has already seen several concrete projects, based on careful analyses and estimates of potential, where Industry 4.0 and the ensuing opportunities become reality.

Pic. 1: AZO defines the 4P as a goal to implement Industry 4.0

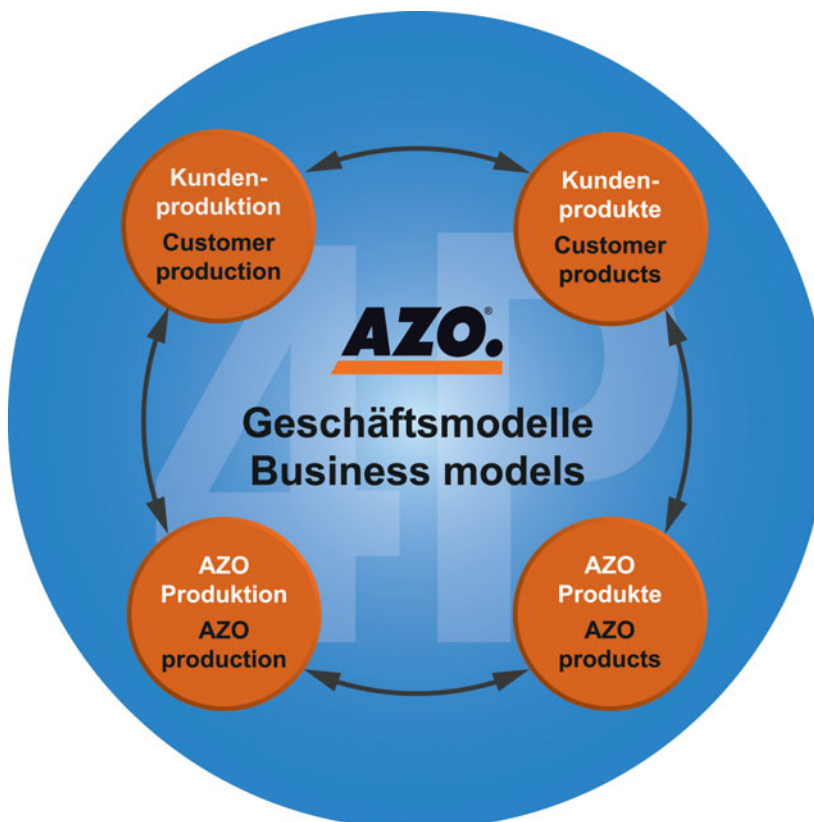

In many companies Industry 4.0 (or the Industrial Internet of Things) is currently a work-in-progress that not everyone is willing to tackle. The first enterprising projects indeed demonstrate what digitisation can lead to, for example in the sectors of additive manufacturing, virtual reality and robotics. The plastics industry and its customers in particular can have high expectations.

However this work-in-progress still appears chaotic to many and, above all, huge in magnitude. Where do you start? If you want to build a house, a really big one with all the latest gadgets, the very latest in technology, a sophisticated energy concept and – for the possibly still distant future – accessible for disabled users, you will know: it doesn't happen overnight. You need to allow sufficient time just to give thorough consideration alone, which of the dreams it is absolutely essential to realise, which are only maybes and which should not be realised until a later date. Some

things have to be provided from the outset, others can be "added on" years later without difficulty, as long as they were included in the planning. And then again other things may be just "nice to have" – in this case the property owner needs to give careful consideration to whether their available resources allow investment there.

Industry 4.0 and compounding

There is probably an almost unlimited number of "house pipe dreams" in the plastics industry. And in the compounding sector too, which stands to make huge gains from connectivity, big data, monitoring and information exchange: gains in quality, efficiency and ultimately increased profit – for businesses and for society. This is demonstrated by the first projects from the plant engineering company AZO, for example a project in collaboration with Huber+Suhner, a Swiss company specialising in cable compounds. To achieve its strategy of zero errors, Huber+Suhner, working with plants and automation engineering from AZO, was already employing methods in 2011 that come very close to Industry 4.0 in many respects. [evtl. Verweis auf Video <https://www.youtube.com/watch?v=2QNBI3coWu0>

Testing Industry 4.0 elements for their efficiency, before the details for the entire structure have been thrashed out, is justified. It is equally justified as it would be for a home owner to first test a modern method of energy supply in their old home. However that does not save them the work of giving careful consideration as to how they want to design their new house with all its features. In view of the positive experience with Industry 4.0 tools, AZO management also took a step back in order to obtain a broader perspective of Industry 4.0: What is good policy? What is feasible – from the aspect of existing resources and capabilities? Which projects should be set up for it? And what order and priority should be allocated to the individual projects?

A sound basis – and carefully planned steps guided by the 4 P

This is how to establish a solid foundation for the future with Industry 4.0. The ground was well prepared this – a site with existing infrastructure, as it were. Dieter Herzig, manager of AZO Controls, underlines: "We have given some thought to methods such as integrated engineering or tracking & tracing since back in 2006, issues that are included in Industry 4.0 today." The management was able to build on this when in 2014 they asked: what does Industry 4.0 mean for AZO and its customers? It was intended that the VDMA's (German Federation of Engineers) "Guideline Industry 4.0" for SMEs should provide guidance for the company's projects. Karl-Heinz Bußbach, head of the AZO Poly division, recalls: "We started actual work on this in early 2015. We first looked for an external partner to assist us in adopting a new mindset in the company." Our chosen partner, KIT, the Karlsruhe Institute

of Technology, had already been instrumental in drafting the VDMA's guidelines for Industry 4.0. AZO therefore chose to have input from external experts instead of the alternative, which was to preside over the entire process itself with the help of a train-the-trainer measure offered by the VDMA. Bußbach: "This meant we also gained an objective view from the experts at KIT."

Horizontal and vertical integration, end-to-end engineering and not forgetting the human as director in creating value are important cornerstones for every business moving towards Industry 4.0. AZO intends to be guided – this was the strategic goal decided in the workshop – by the four Ps: the customers' production and products and AZO's own production and products. Above and beyond this, the goal is to develop new business models. Bußbach says: "As digitisation increases, more and more customers in the plastics industry expect that from us, but so do customers in other markets."

Practicable VDMA toolkits...

However before anything can be developed or strategy rethought, it is essential to know where you stand. AZO made use of the VDMA's so-called Industry 4.0 toolkits to this end. They provide six criteria each with five levels, allowing classification with regard to Industry 4.0, for products and production. For example, the characterisation for integrated sensor technology: products without any sensor technology were to be attributed to level 1, those with integrated sensors to level 2, level 3 included products that themselves process the sensor data, level 4 had products that also evaluated the data for analyses themselves and finally products, which respond autonomously as a result of the data obtained, were attributed to the highest level 5. Definitely important criteria for many of the complex machinery in AZO's product portfolio for the plastics industry. For instance, a pneumatic vacuum conveying system, equipped with additional sensor technology, can itself

Pic. 2: VDMA's Industry 4.0 toolkits

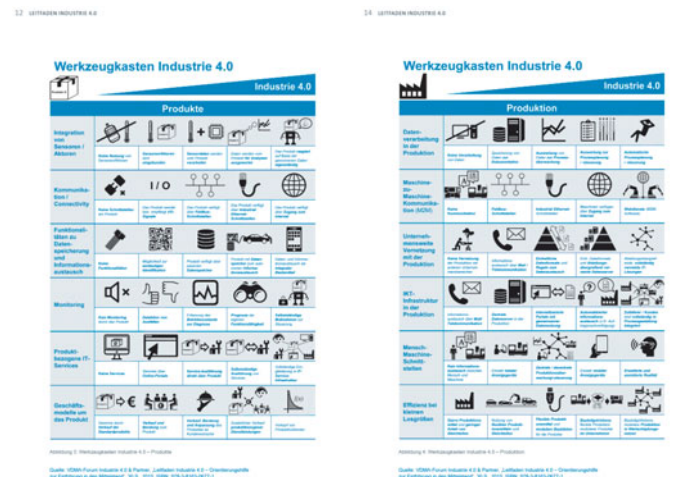

Quelle: VDMA-Funktionale Leitlinie 4.0, 2015. (Leitlinie Industrie 4.0 - Checkpoints) www.vdma.net/leitlinie40



Pic. 3: In workshops ideas are examined for their market potential, their benefit and viability

determine its optimum operating point depending on the properties of the raw materials. Similarly, improvements can be achieved for planning service measures in the sense of condition monitoring and predictive maintenance, for instance as a result of changes in differential pressure or an increase in fine particulates in the clean air.

...but the subject of engineering is being neglected

AZO indeed considers the toolkits to be helpful, even if “the engineering aspect has not been included” as Herzig criticises. “There is very substantial added value specifically in the engineering for plant design and construction.” Nevertheless, after thorough preparation with the help of the toolkits, AZO succeeded in conducting a rigorous analysis of its products. “Once we had classified our products, we agreed on several important areas where further development is needed”, explains Bußbach, “but we didn’t want to tackle all six sections from the toolkit at once. We wanted to proceed with selected issues in manageable stages. Apart from the criterion for ‘integration of sensors/actuators’, the plant engineering company from Osterburken identified connectivity and communication as a major area where action is particularly necessary. AZO continues to move forward on issues such as monitoring and data storage, although the company already considers itself in a good position there with regard to Industry 4.0.

Until it is possible to further develop products for the purposes of Industry 4.0, creativity will be called for in phase 3 of the Industry 4.0 project. Ultimately it should culminate in a new product or business model, which requires ideas to be examined for their market potential, their benefit and viability – phase 4 of the project. AZO used the St. Gallen Business Model Navigator recommended in the VDMA guideline as it examines all these criteria from every angle. Ideas which promised great market potential

but were assessed as too tight for the existing resources, were rejected just as were ideas, which, while considered relatively easy to realise, would however deliver too little added value for AZO and its customers.

Careful assessment of added value, market potential and feasibility

Anyone casting a glance at the bulletin board that AZO’s project team was then using for generating and clustering, will soon recognise: collaboration with the KIT released considerable energy: there was no shortage of ideas. For a mid-sized company in particular however, it is important to remain focussed in the last phase of the process, the actual implementation: on issues that are as high as possible on the right in the matrix for potential and strengths. Ultimately AZO identified five projects, four of which are already being actively implemented today. Integrated engineering, pneumatic conveying 4.0, unambiguous product identification and the screener as Industry 4.0 component.

Integrated engineering generates added value immediately in the company itself and has positive knock-on effects for customers, according to the head of the plastics engineering division: “Engineering is not only faster and more affordable; we can also provide the customer with valuable information in this way.”

Added value from the combination of identification technology, mobile terminals and information portal

Implementation of the “unambiguous identification” project also seems relatively straightforward. At AZO this means it is possible to identify integrated plant components at any time and link them with information about their life cycle. Bußbach clarifies: “When backed by an information portal, you obtain valuable information about every component rapidly – whether using QR codes, barcodes, RFID or a rating plate.” When were the filters last changed? Which product is in which receiver at this particular moment? Which individual parts have been built in a component – which motor is in the agitator, which screw feeder in the dosing weigher? It is easy to imagine that the information portal required at a plant engineering company will be extremely complex. Nonetheless

Pic. 4: Matrix for potential and strengths to identify the Industry 4.0 projects AZO will implement

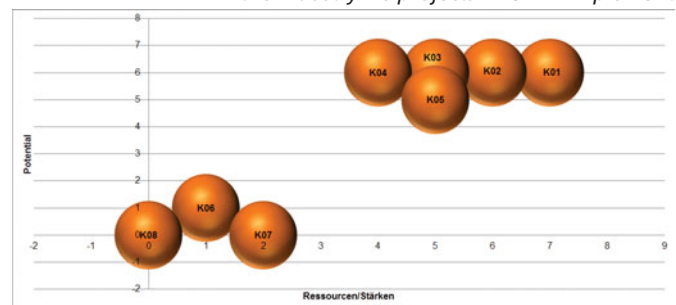

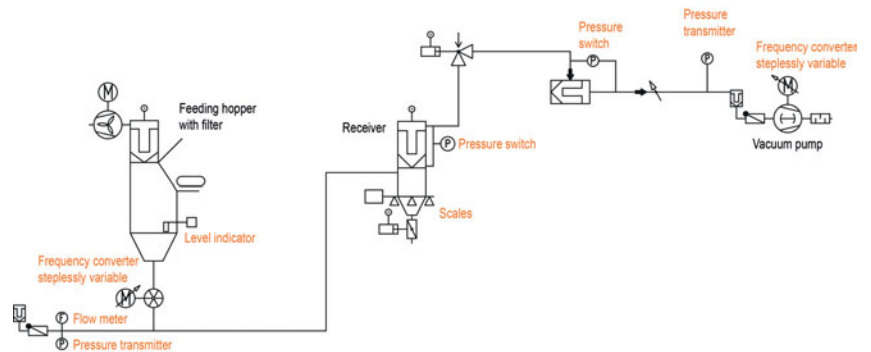
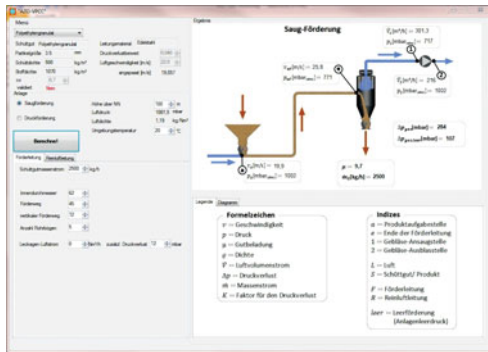

Pic. 5 and 6: Requirements for an intelligent conveying: a program for system design and additional sensor technology

AZO intends to drive this project forward at full speed. The entire service area with important plant data should soon be available for the operator.

“We have already implemented connectivity for the individual control systems”, says Herzig. “This is where we are now working on changing over to OPC UA in order to obtain a structured database.” Karl-Heinz Bußbach promises concrete innovations for Industry 4.0 in time for K 2016 in October.

The project also plans for one Industry 4.0 component to be implemented. How did AZO decide which product to fit with additional sensor technology and intelligence? Bußbach explains: “We asked ourselves: where is the added value for our customers and ourselves? Which projects will deliver the most? Do our customers even want this? And does our development department have the resources to put it into practice? At least one of the 4 Ps - AZO’s or its customers’ products or production – would have to benefit permanently from the increased intelligence for AZO to drive development towards Industry 4.0 over the long term.

Data exchange within the plant system

The RAMI 4.0 reference architecture model for Industry 4.0 has also been put to intensive use here. The automation expert Herzig explains: “We concentrated on the different layers and asked ourselves: What could be the demands on our equipment from these layers?” They gained some surprising insights, for example that it could make sense to integrate a humidity sensor, although humidity is not a significant factor at this point in the process. “However it was very easy for us to determine it at this point in the product flow”, explains Herzig, “and ‘sell’ the value to another machine, which can derive useful information from the humidity level.”

Industry 4.0 system for “intelligent materials handling”

This may sound like a very long way off. However the first Industry 4.0 components have become reality at AZO: the self-optimising pneumatic conveying system could soon be employed by the first customers. The data needed for this are also available for existing plants to some ex-

tent. They are obtained from the design of the conveying system. In addition, the key physical data on the raw material being conveyed are, for instance, an advantage in starting with the correct basic settings. Additional sensor technology is then still needed for intelligent conveying as defined by Industry 4.0. The aim is to ensure that the quantity of air and speed of the rotary valve are always adjusted automatically for the optimum operating point. That cuts operating costs and reduces times for commissioning. Condition monitoring also makes predictive maintenance possible, which further improves plant availability.

Bußbach is convinced that additional intelligence will also be integrated for the loss-in-weight feeder. And the added value? Bußbach explains: “For instance, we can infer potential system errors from changes in bulk density, combined with other data such as screw feeder speed: an example would be the screw feeder becoming blocked. Parameters such as the refill points can be adjusted automatically in this way too.”

Paving the way for the digital future

A lot of work remains to be done, years of work, before all of AZO’s products and processes have been scrutinised with regard to integrated sensor technology, connectivity and other features of industry 4.0 and improved as necessary. Needless to say, we want to be ahead of the game where the competition is concerned since we are a high-performance supplier. The greatest benefit – which both Herzig and Bußbach agree on – results however when plant engineering companies and operators adopt a broader perspective and then ask which information is important for upstream and downstream systems. Bußbach emphasises: “All manufacturers need to consider which data interfaces they will provide in future.” Even if Industry 4.0 is still today still in its infancy – plant and machinery engineers such as AZO, who are undaunted by the complexity and who, after due consideration, will systematically implement the first Industry 4.0 projects, will be the pioneers for the digital age.

Configuring in next to no time

The ScrewCon configuration software developed by KraussMaffei for screw and housing elements of twin-screw extruders has proven its excellence for over twenty years. The latest 3.0 version of this program comes with a completely new user interface with numerous innovative features. ScrewCon is now also available for use by our customers.



Configuring twin-screw extruder processing sections in next to no time

Ultra-rapid configuration based on about 2,000 screw and barrel housing elements

"ScrewCon offers an impressive array of resources. There is a library of about 2,000 screw and barrel housing elements the user can choose from for the different twin-screw extruder sizes in the ZE BluePower, ZE UTi, ZE UTXi and ZE Basic series. Customized configurations for specific requirements and individual machines can be prepared within a minimum of time," says Andreas Madle, responsible for process-engineering developments at KraussMaffei Berstorff and in charge of the complete redesign of the ScrewCon software. "In addition, the configuration process is extremely simple using the click and drop function."

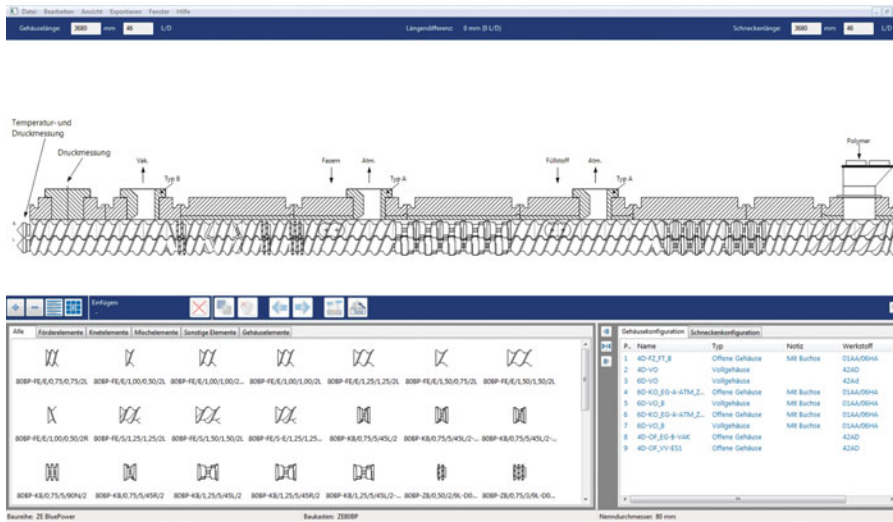

ScrewCon 3 – unparalleled user-friendliness for processing section configuration

The ScrewCon 3 software used for this purpose is a proprietary product of KraussMaffei Berstorff. This Windows-based solution is characterized by unparalleled user friendliness. Owing to the intuitive operator guidance, no specific previous knowledge is required to use the software. Combined with the extensive portfolio of integrated features, this unsurpassed ease of use turns ScrewCon 3 into an ideal tool for designing and documenting the set-up of twin-screw extruder processing sections.

The clear and true-to-scale visualization of screw and housing elements substantially reduces the time required to prepare tailored configurations. As the two elements are directly displayed below each other, screws and barrel housings can be perfectly adapted within shortest time. The user will be able to see instantly whether the two selected elements match or not. In addition, the screw elements can be precisely positioned relative to the barrel housing openings.

Inventory management for screw and barrel housing elements
The inventory management feature for screw and barrel housing elements offers added benefits to customers. While configuring the extruder set-up best suited to the current requirements, users can automatically view the available stock of elements needed for their purpose and will thus know instantly whether the desired configuration can be implemented or not.

Individual screw configuration
A further highlight of the new ScrewCon 3 software is the simultaneous on-screen display of right and left screws of the twin-screw extruder. Each screw can thus be individually designed and even different elements can be selected for the two screws, if required. In this case, system visualization also helps to avoid installation errors when configuring left and right screws with different screw elements.

www.kraussmaffeiei.com



a DOWER company

www.maag.com



maag pump & filtration systems

Strong history. Bright future.

Maag. Gala. Automatik. RE Scheer. The brands you know and trust proudly building better solutions for you, together.



gala automatik underwater pelletizers



automatik scheer strand pelletizers



reduction pulverizing systems



To learn more, visit us at our three locations at K-Show: Hall 9, Booth A04 (Main Booth) - Booth B65 (Innovation Booth) - Booth E37 (Pulverizer and Strand Pelletizer Booth)



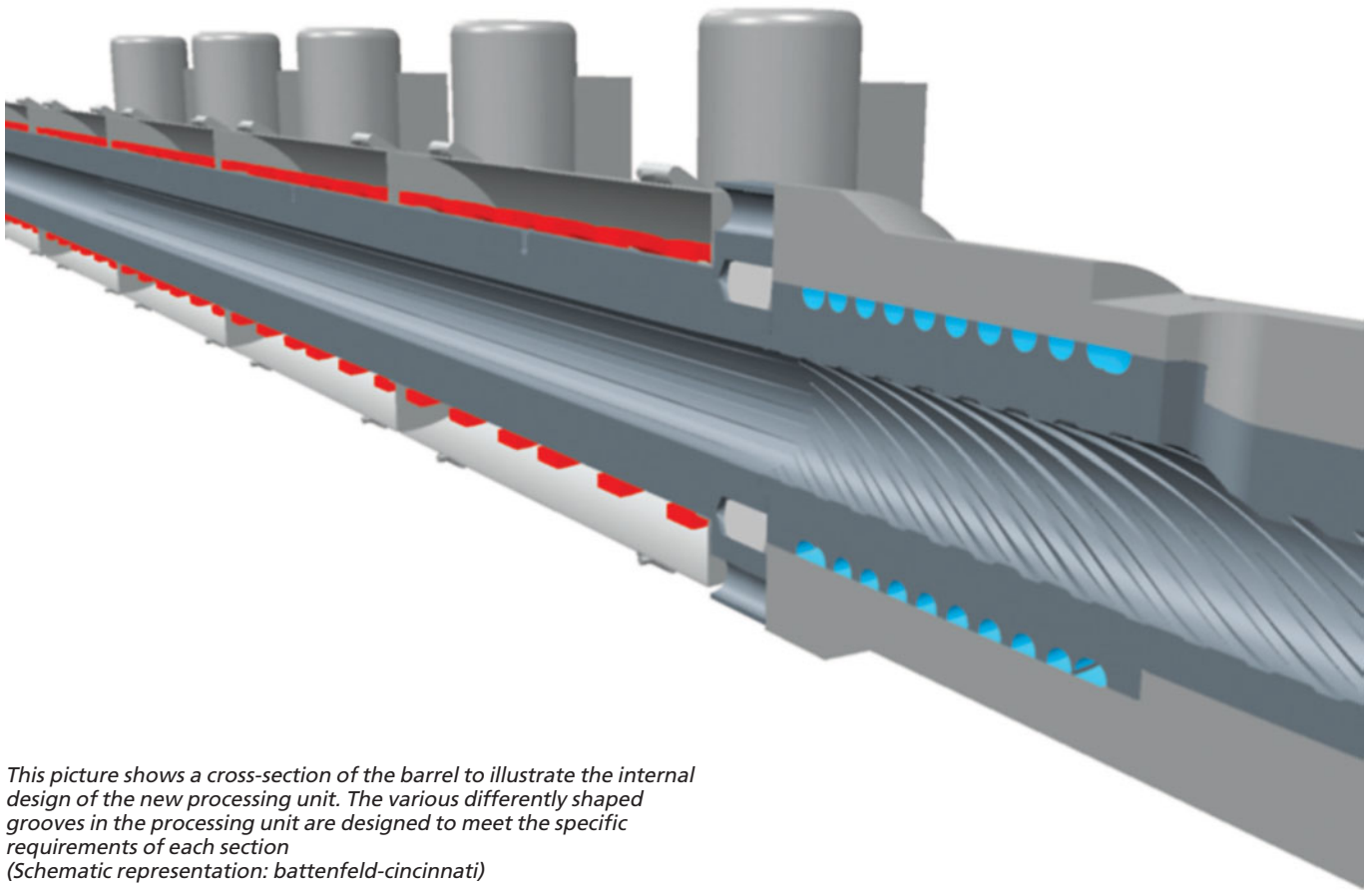

*This picture shows a cross-section of the barrel to illustrate the internal design of the new processing unit. The various differently shaped grooves in the processing unit are designed to meet the specific requirements of each section
(Schematic representation: battenfeld-cincinnati)*

Lower melt temperature, less energy consumption and cost reduction

At this year's plastics trade fair, battenfeld-cincinnati will be introducing a newly developed series of high-performance single screw extruders: the solEX NG (NG = Next Generation) series. Developed on the basis of the proven solEX series, this new generation features a completely new processing unit which offers a multitude of advantages, such as a lower melt temperature and energy costs reduced by up to 15%.

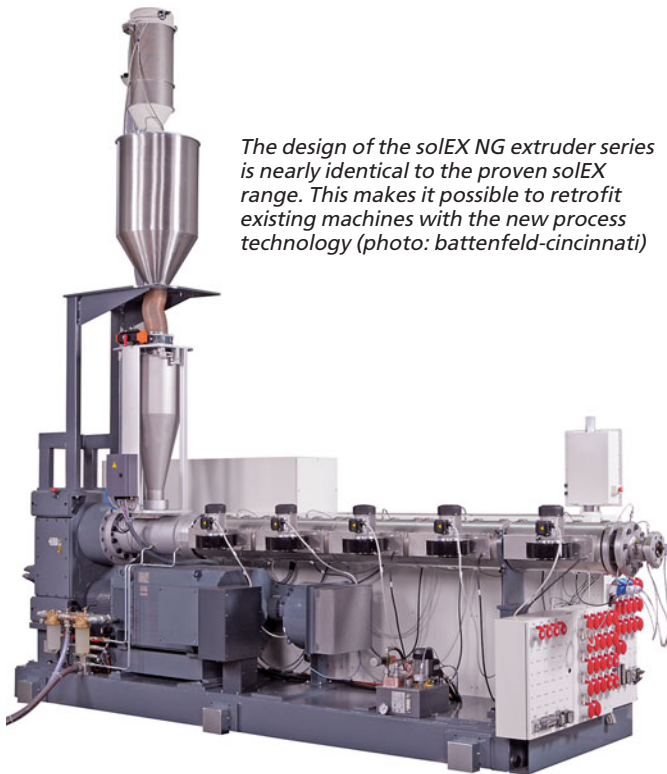

The design of the soleEX NG extruder series is nearly identical to the proven soleEX range. This makes it possible to retrofit existing machines with the new process technology (photo: battenfeld-cincinnati)

Based on the proven soleEX 40 D extruder series, which had already been designed for high-performance applications, the battenfeld-cincinnati engineers have now successfully developed a new groundbreaking processing unit. Barrels, screws, and grooved bush have all been completely redesigned.

The major changes are an internally grooved barrel, a screw concept that consistently applies the theory of dispersive melting, as well as a feed zone with a completely revised geometry and fitted with spiral grooves. All three components are ideally matched, thus enabling a further improvement in the process attributes.

The soleEX NG extruder series is available in four sizes (60, 75, 90 and 120 mm) and offers outputs ranging from 1,000 to 2,500 kg/h – an increase of up to 25% for each machine size compared to the original soleEX series.

One of the benefits offered by the innovative design of the processing unit is an increase in melting capacity, along with gentle and energy-efficient processing. Thanks to this, the melt temperature in the extruder is reduced by up to 10°C for comparable outputs, while the melt homogeneity remains at a consistently high level.

The modification in the conveying mechanism leads to a significant reduction of the axial pressure profile in the feed zone and the barrel, thus reducing pressure across the entire system and enabling an increase in the specific output level. In addition, the processability of regrind is improved, so that higher amounts of regrind can be processed without impairing process behavior. Furthermore, it is expected that wear behavior will also significantly improve, which contributes to considerably higher process re-

liability when using critical materials. Less wear means lower maintenance costs and consequently higher efficiency. In this context, the reduction of energy consumption thanks to the new processing unit is another decisive factor. Energy cost savings of up to 15% are possible: Firstly, less drive energy is required and, secondly, due to the cooling of barrel and grooved bush significantly less heat discharge is necessary. And the new processing unit offers yet another advantage: As the basic structure of the extruder was retained from the previous series, existing soleEX models can be retrofitted with the innovative NG processing unit.

The soleEX NG series not only complements the wide range of battenfeld-cincinnati single and twin screw extruders, but also the portfolio of solutions for large-diameter pipe extrusion, where battenfeld-cincinnati is the technology leader. The soleEX NG extruders with their high outputs and excellent melt processing capacities are ideally suited for PO pipe lines with diameters of up to 2.6 m.



Hall 16, Stand B19

www.battenfeld-cincinnati.com

H E L I B A R ® T E C H N O L O G I E

Multi Strand Extrusion Line

- One step multi-extrusion
- High flexibility
- Few floor space

Hall 16,
Stand F29

KOMAX

2, rue du Maine - 68270 WITTENHEIM
Tél. + 33 3 89 64 36 19 - Fax + 33 3 89 64 21 78

www.komax.pro

info@komax.pro

Open House at the Extrusioneers

Reifenhaeuser Blown Film's presented EVOLUTION Ultra Flat

Reifenhäuser Blown Film hosted an Open House in Troisdorf during the DRUPA trade show held in Düsseldorf. A multitude of customers from around the world attended the event to learn about new opportunities in the application of film extrusion technologies.

What made the Reifenhäuser Open House event so appealing were the lines in operation: Three state-of-the-art blown film lines could be viewed running in production. A special highlight was the EVOLUTION Ultra Flat technology which has become a convincing selling point. Eugen Friedel, Senior Sales Manager at Reifenhäuser Blown Film comments: "Film flatness imperfections occurring in the production of packaging films are inherent in blown film processes. Especially in the conversion of these films they can cause serious problems. With EVOLUTION Ultra Flat featuring minimum stretching of the film via heating-cooling rolls it is possible to produce a web perfectly flat for subsequent winding and conversion." The enhanced efficiency covers the entire value chain. "All steps in the production of packaging film, such as lamination, print-

Visitors from around the world informed themselves about new opportunities in the application of film extrusion technologies at the Open House held by Reifenhäuser Blown Film during DRUPA



ing, re-forming and sealing, clearly benefit from the optimized web flatness," says Eugen Friedel explaining the advantages of Ultra Flat. Arguments that could convince, as three lines were sold with Ultra Flat during the Open House.

Beside the Ultra Flat technology further highlights were presented by Reifenhäuser Blown Film on their running blown film lines:

- 11-layer blown film line producing an outer layer from polyamide:

Here an asymmetric high-barrier structure was so skillfully chosen that the curling effect of the film was prevented without using a water bath (critical for hygienic production conditions). Curling of the film edges is caused by the different speeds at which raw materials cool down and by the individual crystallization points (for example PE vs. PA, PET). That impedes a smooth conversion of the film. Excellent film properties needed for conversion, lamination and printing were also ensured by the EVOLUTION Ultra Flat haul-off used on this line.

Thanks to minimized stretching via heating-cooling rolls, a web of perfect flatness was achieved with this technology.

- 3-layer line producing FFS bags (Form, Fill & Seal) from an LLD-PE rich based material structure regarded as difficult. Operated with a 175mm die, the line easily achieved a consistent record-breaking output of 450kg per hour.

- 5-layer line designed for high output producing high-efficiency lamination film - over 800kg/h were achieved using a 325mm die.

Here as well, the advantages of the EVOLUTION Ultra Flat technology were demonstrated.

► www.reifenhauser.com
www.reifenhauser-bf.com

In the worldwide growth industry of PET packaging sheet, Gneuss has installed over 20 tailor-made sheet lines over the last few years. Gneuss' customers find the extreme flexibility of the Gneuss Processing Unit (GPU), consisting of MRS extruder, Rotary Filtration System, Online Viscometer and Control System completely convincing when processing PET, whether virgin or recycled material and with or without food contact requirements.

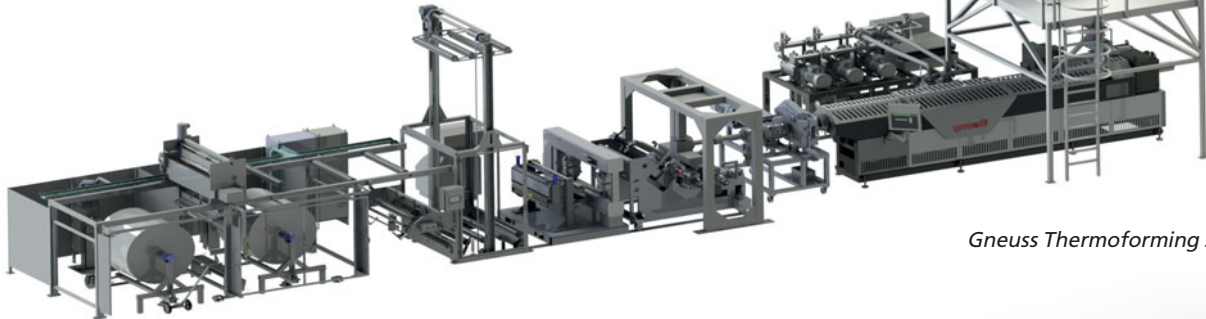

Gneuss Thermoforming Sheet Line

Increased Flexibility and Food Contact Certification

Machinery manufacturer from Bad Oeynhausen (Germany) delivers complete, tailor-made PET Sheet Lines

Within the packaging industry, the use of PET sheet is on the increase and the use of recycled material is likewise on the increase. Whether the PET sheet is used for transparent packaging for food (trays or tubs for fruit, vegetables, meat, cookies etc.) or for non-food (such as blister packaging) it is always important to take account of the particular properties of PET and it is exactly this which Gneuss has done.

With the Multi Rotation System (MRS) Extruder, Gneuss has developed the only extruder specifically designed not only with the material PET in mind, but with the reprocessing of PET. With the MRS extruder Gneuss offers a processing unit which enables PET to be extruded cost effectively, without any pre-drying or crystallisation. This applies both to the processing of both virgin and post-consumer bottle flake with a residual moisture level of 1 % and in some cases more. The extruder will also easily handle PET/PE scrap (laminated sheet) and mixtures of PET and PETG. Thanks to the extremely

high polymer surface exchange rate under vacuum in the MRS section, a vacuum level of only 25 bar is required in order to achieve 100 % moisture extraction. Another effect of the extremely high polymer surface area exchange rate under vacuum is the excellent extraction of volatile contaminants. The system achieves the requirements of both the FDA and EFSA without restrictions PET sheet made on the MRS extruder is therefore suitable for food contact applications whatever input material is used and without any pre-treatment of the input material.

The Gneuss Processing Unit includes also the unique Gneuss Rotary Melt Filtration System for the efficient removal of solid contaminants with fine filter elements even on post-consumer bottle flake. The Gneuss Online Viscometer ensures a consistent, defined IV value of the polymer thanks to the intelligent control system and is an extremely useful tool for quality monitoring and control. Gneuss offers complete lines including the up- and downstream components from the mate-

rial dosing system to the die, roller stack and to the winder, which are all tailored to the exact requirements of the individual customer. As Dr. Carl-Jürgen Wefelmeier (Manager Business Unit Film and Sheet) was pleased to inform us: "We are very proud that we can offer turnkey PET sheet extrusion lines – from the project engineering to After-Sales-Service".

Gneuss can offer individual systems, whether it be for the replacement of existing, conventional extruders in existing lines with Gneuss Processing Units or the design, supply and commissioning of a complete new PET sheet line. In each case, sheet with a high transparency and gloss, extremely low haze and low yellowness with good thermoformability can be made with great efficiency.

The complete sheet extrusion lines are highly flexible with regard to the input material and with regard to the sheet which can be made on them, including even sheet for optical applications.

► www.gneuss.com

“The ideal system for all requirements”

PET bottle flakes



In addition to providing its own, market-tested technology for producing high-quality strapping tapes, Reimotec also supplies the extrusion lines for producing the polymer melt. Today's major challenge for this application is the ever-increasing share of recycling material in the resin, usually consisting of PET bottle flakes, in parallel to similarly increasing quality demands that are placed on the end product – namely the strapping tape. Previously, lines for PET strapping tape were equipped exclusively with single-screw extrusion systems until Reifenhäuser introduced its twin-screw technology (Reitrueder) in 2001 and initiated an important step in the market towards the improved processing of PET bottle flakes.

Since 2001, approximately three quarters of the strapping tape lines supplied worldwide by Reimotec have been equipped with this twin-screw technology: a transformation that is primarily due to the ease of applying this technology to the processing of PET bottle flakes.

A major advantage of the twin-screw, compared to the single-screw technology, is its better suitability for technically demanding recyclates.

However, if the *iV* value of these raw materials is too low, the twin-screw extrusion reaches its limits. In order to meet the demands for processing raw materials even with critical *iV* values, Reimotec has now linked up

Reimotec Maschinen- und Anlagenbau GmbH is expanding its range of PET strapping tape lines by including the VACUREMA system from recycling specialist EREMA in its supply range.

Reimotec is the Reifenhäuser Group's specialist in strapping tape production lines and one of the most experienced suppliers in this market segment, with more than 100 lines delivered for this application since 1977.

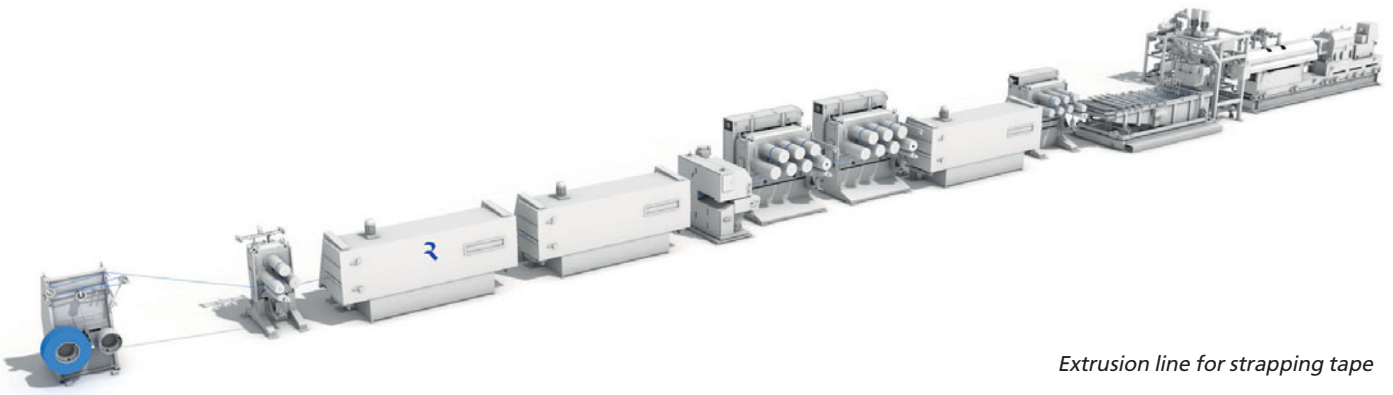

Extrusion line for strapping tape

with EREMA, the Austrian specialist for recycling of plastic materials, thus gaining an invaluable supplier offering another uniquely positioned technology.

EREMA offers the VACUREMA system, consisting of modular, scalable components that can be adapted to meet the specific requirements of customers, depending on the quality of their PET bottle flakes.

Both companies are technology leaders and have been meeting the challenge of matching the ever increasing demands on end product quality with the varying quality of recycled raw materials for years, thanks to their innovative products.

Reimotec customers are now able to adapt their lines even better to the raw materials available as – in addition to the tried-and-tested technologies using single-screw and twin-screw extruders – they can now also obtain the VACUREMA technology from a single source. At the same time, EREMA customers can now use Reimotec’s proven technology for the production of high-quality strapping tapes. Both companies consider that one of their key tasks is to increase benefits to their customers. As a result of this expansion of the Reimotec portfolio, manufacturers of strapping tape will in future be able to purchase

lines for technically demanding raw materials without the need for customisation. These lines will now also include the VACUREMA technology and as a next step will use the proven Reimotec technology for high-quality strapping tape.

www.reifenhauser.com
www.reimotec.com
www.erima.at

Dipl.-Volkswirt Bernd Reifenhäuser, CEO Reimotec Maschinen- und Anlagenbau GmbH

Dipl.-Ing. Manfred Hackl, CEO EREMA Engineering Recycling Maschinen und Anlagen Ges.m.b.H.



NET
NEW FILTER
GENERATION

FIMIC
ITALIAN MELT FILTER

DOUBLE FILTRATION
IN ONE STEP
ALSO FOR PVC

Visit us to discover new filtering solutions

www.fimic.it

K Düsseldorf
19-26 October 2016
Germany - Stand 10E15

Extruded Pipe and Hoses under Tight Control

ZUMBACH – Swiss Prime Measuring since 1957 – will join the international trade fair for plastics and rubber K 2016 in Dusseldorf. Novel and intelligent solutions as well as cost efficient solutions for in-line measurement and control of pipes and hoses are going to be the focus of Zumbach's exhibition booth.

Material savings thanks to measurement and control of eccentricity and wall thickness. The versatile high-tech ultrasonic system WALLMASTER offers application-specific solutions for measuring and monitoring wall thickness. The measuring data processor with touch-screen display gathers data and QC fully automatically. In combination with ultrasonic UMAC® scanners and various ODAC® diameter measuring gauges as well as with error detectors, the measuring and monitoring scale can be expanded to outside and inside diameter, statistics, SPC and processor communication. Using Zumbach's WALLMASTER measurement and control systems, manufacturers can economise their expenditure of raw materials. The ROI is achieved within a few months. The use of these systems also allows reducing considerably the start-up time.

Optimized measurement of monolayer synthetic pipes and hoses. WALLSTARTER – the low-cost processor solution for UMAC® ultrasonic eccentricity and wall thickness measuring is tailored to the requirements of the measuring and monitoring of monolayer synthetic pipes and hoses.

New ultrasonic scanners for flexible diameter adjustment. This novel construction (pat. pend.) is going to be one of the exhibition's highlights: the transducers can be either individually or simultaneously adjusted to the best possible measuring position within seconds. The scanners cover an outside diameter up to 180 mm and represent a smart and simple solution for full non-contact, in-line eccentricity and wall thickness measurement of tubes, hoses and cable jackets.

High-end Non-contact Profile and Shape Measurement, Combining Laser and CCD Technology

In-line cross-section measurement of plastic and rubber profiles of any kind. The PROFILEMASTER systems from Zumbach represent an accurate and economical solution for measuring and monitoring dimensions or even the complete cross-section of profiles and pipes made of plastics or rubber – throughout the manufacturing process.



Selection of available Zumbach instruments with OPC UA

All relevant dimensions such as width, height, angle and radii are added together to form the full cross-sectional picture.

Linear Sensor Technology allows cost effective, synchronous multi-axis Measurement of Diameter and Ovality in Extrusion Processes

Unique measurement technology for products up to 200 mm outside diameter:

- A new product line with 2-coloured LED light sources allowing simultaneous scanning in each axis (XY*) and thus trouble-free measurement even with product vibration
- Integrated extraneous light filters prevent occurrence of measurement errors that to date seemed unavoidable
- Perfect performance even with reflective surfaces thanks to the use of different colour lighting for each measurement axis

OPC UA: Transparent data management – simple monitoring in real-time

- ZUMBACH equips its powerful instruments with the recognized OPC UA standard. With this key technology, measurement solutions provide easy, scalable and secure information exchange with different systems in the production line – Platform and manufacturer-independent data exchange.



Hall 10, Stand E41

www.zumbach.com

Dear reader,

Now you have an opportunity

**to get immediate notifications when new issues
of Extrusion International are published:**

- 1. Just click the red button down there**
- 2. leave your e-mail address to start getting the announcements**



Learn more about...

Extrusion of film

Extrusion of pipe, profile, and sheet

**Raw materials. The specificity of the extrusion
of PVC, PP, PE, PET**

Masterbatch & additives

Compounding & mixing

Recycling

Die, screw, filtration, granulator, and melt pump

Automatic, control

Peripherals

Converting, printing, and lamination



Blessing and risk – X-ray radiation

Several applications for the ionizing radiation



DNA double-strand break

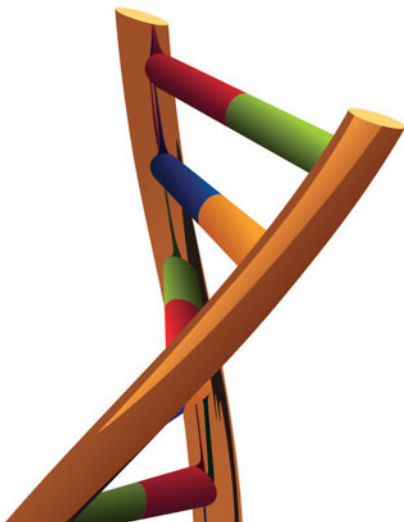

With its moderate radiation, the sun makes all life on earth possible. Nevertheless, humans should not expose themselves for too long to the radiation. Protection is especially necessary when it comes to the invisible, hard ultraviolet rays of the sunlight and hence, the risk of possible skin changes.

X-ray radiation

X-rays, with a spectrum starting where the hard UV radiation devolves to ultra-hard UV radiation, proved as a blessed instrument for many areas, especially for the medical diagnosis and cancer therapy. Also, the X-ray radiation has become indispensable over the last decades for valuable applications in the industrial area. While the energy of the UV radiation rate of the sunlight shows only low penetration regarding the human skin, X-ray radiation is able to penetrate the tissue completely. In both cases, damages of cells in the skin respectively the body may occur, which can result in the malign change of the cells. In principle, all substances of a body cell may be damaged but eventually only damages regarding the hereditary material (DNA) is of importance.

Single and double-strand breaks of the DNA are not only caused by X-ray radiation. Nowadays it is a common understanding that oxygen radicals, produced by the metabolism of a cell, continuously cause DNA changes. Modern methods proved that on a daily basis between 0.1 and 5 DNA double-strand breaks occur per cell. This number is increased with the progressive age. 99.9 % of these damages are eliminated by the

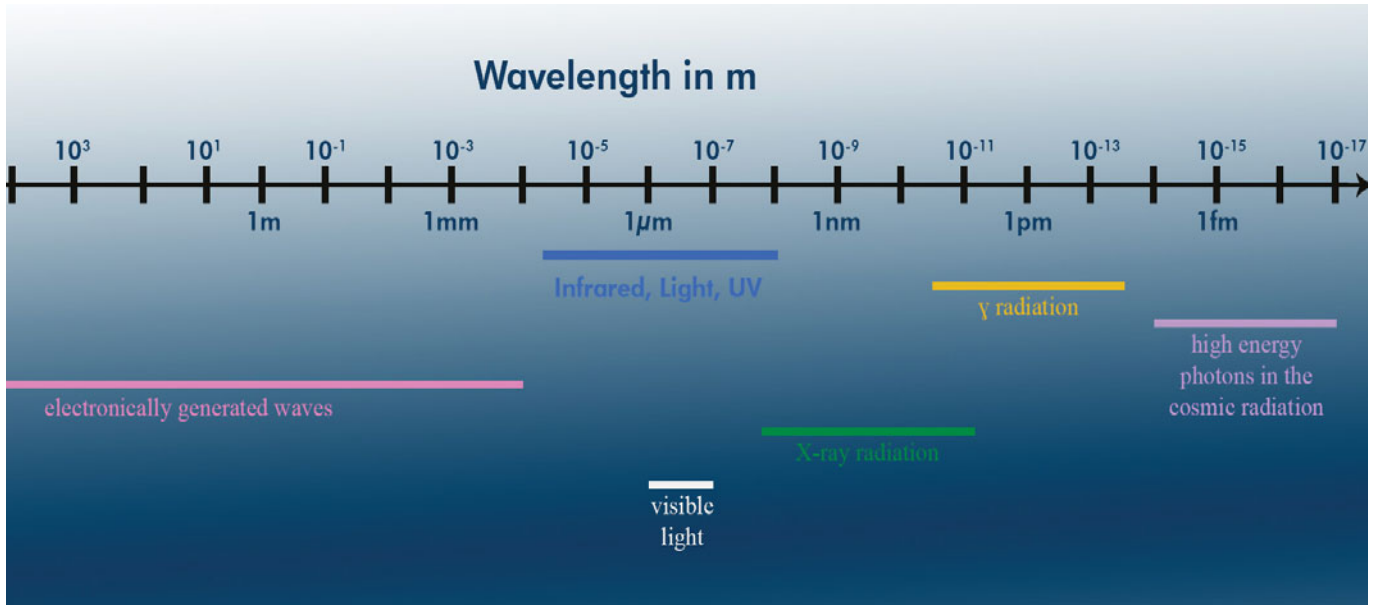

X-rays

endogenous repair mechanism in the cells. Is this not possible, the defect cell is replaced by a new cell.

Evidence of radiation damages

Exposure to ionized radiation contains relative risk. Today, the biological dosimetry is an international recognized method to estimate the dose of a possible excessive radiation exposure. Therefore, special biological marker are used, which are like fingerprints in irradiated cells.

Save handling with X-ray devices

Just as clothes offer protection against the ultraviolet radiation of the sun, also X-rays can be shielded by suitable materials. Materials with a so called high atomic number are especially suitable. Relevant in this context are steel, copper and lead. By using this materials, the X-ray radiation of medium energy, as it is used in industrial measurement technology, can be weakened so much that the omnipresent background radiation on the outside of such a device is only slightly or not at all increased.

Unlike radioactive isotopes, whose radiation can only be shielded but

not turned off, the radiation of an X-ray device can be switched off. Without the anode voltage for the X-ray tube, no X-ray radiation is produced. Also, X-ray radiation cannot cause radioactivity in irradiated materials as the energy of the X-ray radiation is too low to create radiant, radioactive isotopes. Even the X-ray tube, just like all other inner components of the X-ray device, is completely free of radiation after the deactivation of the anode voltage and can therefore be handled unconcernedly.

Blessing and risks

An especially positive aspect of the X-ray radiation is its usage when treating malignant tumors in order to destroy degenerated cells of the tumor with high-energy X-ray radiation. This energy sector of about 10 MeV is called gamma radiation. According to the European directive 96/29/Euratom, X-ray based measuring devices have to be built in a way that its radiation does not exceed the maximum value of 1 $\mu\text{Sv/h}$ at a distance of 0.1 m on the outside of the device. This limit is so low that a significant statistical proof for a possible cancer is not possible.

It may sound astounding, but modern researches point to the complete opposite direction. Namely, a small dose of X-ray radiation, similar to the UV radiation of light, stimulates the immune system and therefore, can even be healthy.

www.sikora.net



www.illig.de

Tradition Forms Future

Coinciding with its 70th year of operation, the thermoforming systems supplier ILLIG hosted its 15th Open House under the banner "Tradition forms Future". The event was held on June 22 and 23 at the company headquarters in Heilbronn, and was attended by some 250 visitors from all corners of the European economic area and from as far away as South America and India.

The performance of the latest thermoformers took center stage at this year's Open House 2016 in ILLIG's 70th year of operation

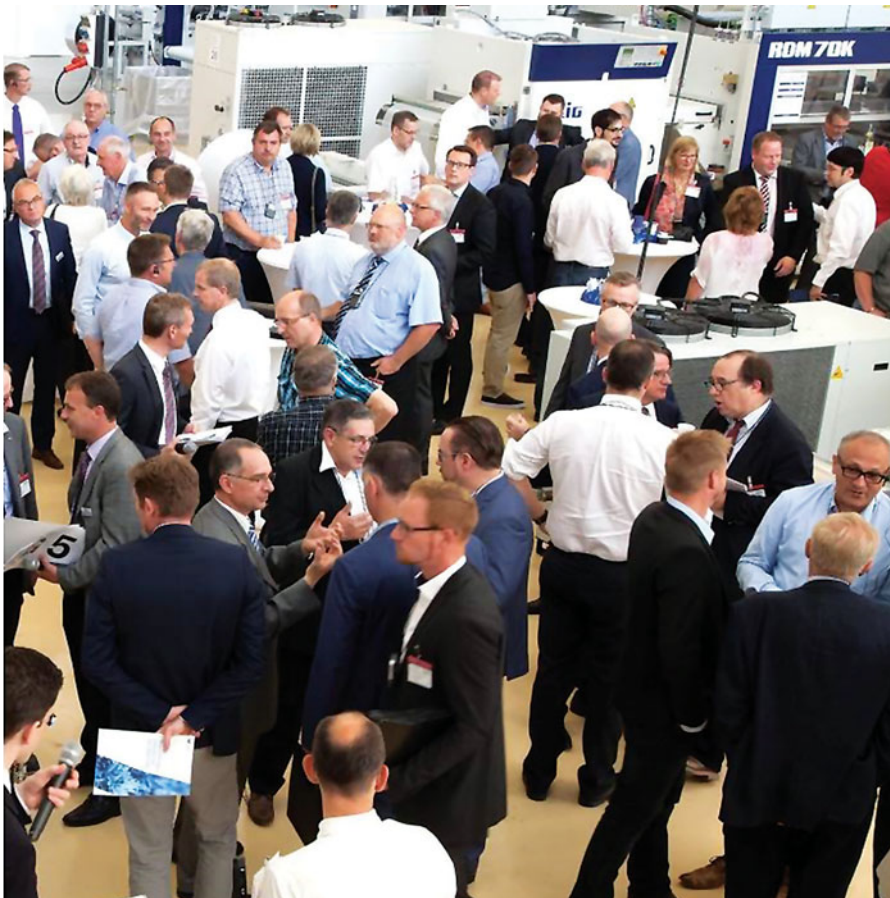

Photos: ILLIG

Now in its 15th year, the annual event hosted by the global market leader of thermoforming systems has become a magnet for networking in the industry. Those in attendance were treated to a wide range of presentations and live machine demonstrations, which included trends in packaging technology, label decoration with In-mold Labeling Thermoforming (IML-T) technology, lightweight molds and end-of-line packaging. A diversity of applications differing in shape and size demonstrated the vanguard of technological innovation on ten of the latest generation, highly efficient and high-performance thermoformers in a real-life production environment.

ILLIG managing director Karl Schäuble also announced the highest number of received orders in the company's storied history. In addition to the developments in technology over the last three years, factors contributing to this success have been identified as the increase in mar-

ket demand for in-mold labeling decoration and, above all, the good economic development in non-European markets. In the coming years, Schäuble sees the demand for more automation and hygienic production processes as the main driving forces of development in the industry: "We expect the increase in the cycles per minute of ILLIG machine lines will continue to be a decisive factor in the near future for high lot-size productions and highly automated production processes. To accommodate this market demand we will continue to improve the cpm-speed in the thermoforming and trimming process, as this will further improve the quality and reliability of the formed parts." To this end, the installation of camera-assisted quality assurance systems will be a contributing factor. Repeated cleaning intervals necessitated by increased hygiene standards are a constraint on productivity, for which ILLIG is also developing solutions.

Of particular interest among the live machine demonstrations was the IML-T on the RDM 70K production line in combination with the specially designed RDML 70b unit: Every hour 17,280 rectangular cups made of polypropylene were produced on an 18-cavity mold that included picture-perfect decorated labeling on all four sides and the bottom of the cups during the forming process.

New at this year's Open House was the latest-generation RV 74d automatic vacuum forming machine with enhanced performance in direct comparison with the previous version. The forming area has been extended, the forming pressure increased by 50% from 2 to 3 bar, and the maximum cycles per minute increased to 40 cpm. The part quality has been further improved by controlled overlapping machine sequences and optimized heating settings. For demonstration purposes, polystyrene food trays were formed on the RV 74d using a 6-cavity mold. Some of the special features of this vacuum-forming machine are its exceptional flexibility, compatibility with cost-effective molds that can be self-made using the included mold-making manual, and its high availability.

The same can also be said for the automatic pressure-forming machines RDK, RDKP and RDM-K. The RDM-K-series cup machines deliver unrivaled solutions for the reliable reproduction of the thermoforming process and its control, currently not offered by any other thermoforming supplier on the market. In combination with lightweight molds, the new RDM 76K (with a forming area of 760 mm x 530 mm) achieves maximum output while simultaneously increasing the service life of the trimming die. In live demonstrations at the Open House this resulted in 126,000 PP sealing rim cups per hour on a 60-cavity mold.



Among the various demonstrations, the visitors took special interest in the IML-T decoration

Coffee capsules made of multilayered PP



Post-consumer recycling – more efficient and economic

Pic. 1: Herbold Wet Granulator HGM 60/200



The manufacturer of machines and plants from Meckesheim/Germany was presented at IFAT 2016 in Munich new solutions for washing, separating and drying of plastic waste featuring low operating costs and higher efficiency. In the front of the line is the HERBOLD wet shredder HGM: beginning at the pre-size reduction step water is added, which is new. Until recently, water was only used in the granulation process where further size reduction occurred.



Pic. 2: Post-consumer film

Approximately 25 years ago, Herbold made the wet granulation technique marketable and with it set standards in the industry. The advantages of wet granulation are obvious; less wear and tear, no plastification due to the optimum cooling during the size reduction process, and a very effective separation from the first processing step.

The Herbold Wet Shredder (fig. 1), inside equipped with exchangeable wear plates, shreds the infeed material by the simultaneous addition of wash water. The coarsest impurities are already washed off during the first process step.

Above all, this technique is well suited for highly contaminated material such as agricultural film. It is also suitable for post-consumer film from households (fig. 2) and wet granulation has significantly increased the life between knife changes enabling a more economic operation. Even problematic material such as wood



Pic. 3: Hydro cyclone and Dryer, in the background Pre-washing unit

and paper fractions inside the input material can be handled better through the wet shredding as water allows for liberation from the material early on in the process.

Further developments such as pre-washing units, granulators with forced feeding, hot wash steps with ultrafiltration and hydro cyclone separation steps reduce energy costs,

process but also for the following process steps in a washing line. The washing line itself is no longer contaminated by extreme impurities, hence the components have a longer operating time and the final product quality improves.

Retrofitting and upgrading of existing plants is an important topic – HERBOLD MECKESHEIM assists with expert technicians in order to incorporate the experiences of more than 300 installed wash and separation plants. In the new technical center in Meckesheim near Heidelberg where currently extensive enhancements are carried out HERBOLD MECKESHEIM develops solutions in collaboration with the customer. A first trial with the customer's original material is free of charge; the tests are processed with machines in industrial scales.

Engineering, Manufacture, Delivery:

Pic. 4: Flowsheet Herbold Meckesheim

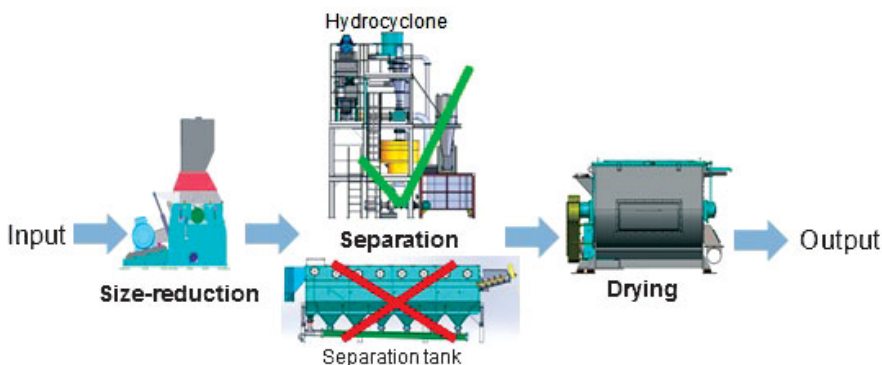

Global premiere of XTREME RENEW at the EREMA Discovery Day 2016:

Direct processing of PET flakes for food contact compliant inline preforms in just one processing step

This year's EREMA Discovery Day – now well known throughout the industry – was held at the EREMA headquarters in Ansfelden on 1 June 2016. Over 250 international customers and interested guests once again found the technological edge of the Austrian global market leader convincing this year as EREMA, in collaboration with SIPA, the leading Italian PET packaging solutions' company with 30 years of experience in the field of preform/bottle production and filling plants, presented the recycling system XTREME RENEW. This achievement enables direct and flexible processing of washed PET flakes to produce preforms, signalling the dawn of a new era in PET recycling.

EREMA Discovery Day 2016: PET Recycling, Inline Applications & Bottle-to-Bottle



Photos: EREMA

From sorters and washing plant manufacturers to downstream producers, fillers and brand owners, representatives from the entire PET recycling value chain were present at the EREMA headquarters. The expectations of the interested attendees were high as, further to the currently low oil price, the conclusion may be drawn that PET recycling is not profitable at the moment. "In my experience with customers, the reason why a producer decides in favour of a major investment in a recycling solution is based on a broad-sighted, entrepreneurial approach. Only those companies which are willing and able to adapt will remain in the constantly fluctuating plastics industry in the long term. Thanks to the collaboration with SIPA we make it possible for plastics producers to show the necessary flexibility," says Christoph Wöss, Business Development Manager for Bottle Applications at EREMA. The cooperation between two big players in the plastics industry made it possible to develop a direct processing solution which stands out through better preform quality characteristics when using rPET.

The food contact compliant melt produced by VACUREMA® runs when hot and thus without the otherwise common, intermediate cooling stage in pellet production directly into the XTREME production process developed by SIPA to make preforms in a single step. The benefit of this direct processing, therefore, is an enormous boost in energy efficiency plus considerably lower thermal damage to the PET material. Enrico Gribaudo, SIPA General Manager, notes: "We are proud to have developed such a sustainable product together with EREMA. Sustainable in the sense of the company and sustainable in the sense of the environment. Moreover, the processing gives you unrivalled benefits in logistics. XTREME RENEW not only saves space, CO2 and energy, it also reduces costs."

1.2 million tonnes of PET recycled so far worldwide with VACUREMA® technology

Some 1.2 million tonnes of PET are already recycled every year around the world with VACUREMA® technology for end products such as preforms for the beverage industry as well as for thermoforming sheet, fibres, strapping, etc. This shows that recyclers and producers can count on flexibility in their production processes to react to fluctuating economic factors. The claim of adaptability applies likewise to the highly



Presentation of XTREME RENEW: Gianfranco Zoppas, Chairman SIPA/Zoppas Industries; Manfred Hackl, CEO EREMA; Klaus Feichtinger, CEO EREMA; Marc Jacobs, CEO marcjacobsconsulting; Christoph Wöss, Business Development Manager Application Bottle EREMA; Enrico Gribaudo, General Manager SIPA

efficient MPR® which can be retrofitted to existing extrusion lines. Decontamination, drying, dedusting and crystallisation of different PET input materials take place in just one step. As a result, the washed PET material is already food contact compliant prior to extrusion. VACUREMA® technology offers a very high degree of flexibility in PET recycling which is enhanced even further through the successful collaboration between EREMA and SIPA.

EREMA Group

The company EREMA Engineering Recycling Maschinen und Anlagen Ges.m.b.H., which specialises in the development and production of plastics recycling systems, was founded in 1983. Besides EREMA itself, the EREMA Group comprises the sister companies 3S, PURE LOOP (January 2015) and UMAC (beginning of 2016). With subsidiaries in the USA, China and Russia plus around 50 local representatives in all five continents, the EREMA Group has a reliable network to realise customised recycling solutions for international customers. Around 480 people around the world now work for the Austrian company group which is headquartered in Ansfelden near Linz.

SIPA. The PET Specialists.

For more than 30 years SIPA has specialized in complete manufacturing lines for PET containers, including design, production, filling, and packaging solutions. SIPA tailors technology recommendations to customer needs based on unmatched knowledge and experience of the entire PET process. Headquartered in Italy, the company can rely on 17 sales branches, 3 manufacturing facilities and 28 service centers for fast access to service, parts, and expert engineering support.

The pivotal product from SIPA in the cooperation with EREMA is the XTREME Preform Production System. In this process the PET material is subjected to four times less pressure, which is why preforms with significantly better key characteristics and with up to 10 per cent less weight than in injection molding production can be made.

www.erema.at



MPR – Multi Purpose Reactor complements existing extrusion systems

Roughly 125,000 tonnes of PVC wastes, including window profiles, are recycled each year in Europe. The regenerated material can be used without difficulty for the production of articles for the construction sector such as profiles and pipes. Image: Rewindo



Plenty of potential for recycling

Technologically, plastics recycling is not a problem at all today. In-house recycling has now become established right across industry. For plastics processors who work with pure-grade raw materials, the waste-free factory has become commonplace. And for post-consumer wastes, there are increasingly mature reutilisation strategies, enabling the regranulate produced with them to substitute virgin material without problem. In the last few years particularly, there has been fast-growing demand for recompounds, pigmented and/or reinforced granulates produced entirely from residues. All the same, the industry still has a number of hurdles to take and problems to solve. Profitability, optimised collection strategies, political targets, consumer interests and education, and the design of recyclable plastics products are just some of the core themes.

According to PlasticsEurope, the association of plastics producers, the 1.45 million employees in the European plastics industry in 2014 were working for 62,000 mainly small and medium-size companies that generated total sales of EUR 350 billion. Plastics consumption in the European industry as a whole came to 47.8 million tonnes, with about half, amounting to 25.8 million tonnes, being collected after use. PlasticsEurope investigated the collection rates in the 28 EU states plus Norway and Switzerland and found that there is still strong variation.

Although a ban on the landfilling of plastics residuals has meanwhile been announced in nine countries – Austria, Belgium, Denmark, Germany, Luxemburg, the Netherlands, Norway, Sweden and Switzerland – the proportion going to landfill in the other countries is still very high at as much as 70 per cent. The countries with the highest landfill shares are Bulgaria, Croatia, Cyprus, Greece and Malta. What is compared here is the share of plastics residuals landfilled as against the residuals that are reutilised, i.e. incinerated for their energy content or recycled. Overall, of the total collected residuals in Europe, about two thirds are now reutilised, while 30.8 per cent are landfilled. Of the plastics residuals that are reutilised, about half – 7.7 million tonnes – is recycled and the rest is incinerated to generate energy.

The goal must be to significantly reduce the quantity of landfilled plastics in the coming years and to reutilise more. PlasticsEurope likens the quantity of some 8 million tonnes of plastics that are currently still landfilled Europe-wide to a volume of 800 Eiffel Towers. Experts are therefore demanding more concrete political targets in all European countries, educating consumers better to adopt a more sustainable attitude towards plastics as a resource, and the introduction of improved, nationwide collection and sorting systems.

The main fractions are polyolefins

With about 9.5 million tonnes of PP, 8 million tonnes of PE-LD and PE-LLD and 6 million tonnes of PE-HD and PE-MD, polyolefins are by quantity the plastics most used in Europe, collectively accounting for about half of overall consumption. Because of their quantity and many fields of application, polyolefins account for the lion's share in the recycling streams as well. If these are pure-grade residues, they can be efficiently processed, so there are numerous recycling businesses devoted to polyolefin recycling. Some plastics processors are even going a step further and, in addition to in-house recovery and the direct recycling of their production wastes, operate their own regranulators to produce granulate from their wastes. One such firm is Polifilm Extrusion GmbH in Weissandt-Gölzau which generates 25,000 tonnes of regranulate per year, enabling it to produce bin liners and construction and agricultural sheeting more profitably.

The situation is more complicated when PE and PP are mixed, as they are very hard to separate because of their similar density, and NIR sorting processes are today state of the art. However, PE and PP can also be processed together into high-grade products, as mtm plastics GmbH in Niedergebra demonstrates with its PE/PP regranulate. DSD Resource GmbH in Cologne specialises in the processing of the pure PP fraction. "We rely on a defined, reproducible starting blend so that we can produce defined, reproducible regranulate in attractive colours," explains Managing Director Dr Michael Heyde.

PET recycling established but with room for expansion

PET, most of which is used for the production of bottles, accounts for almost 7 per cent of total plastics consumption per year in Europe or about 3.1 million tonnes. Overall, the 30 countries of Europe achieve an average collection rate



Trenntechnik Ulm GmbH has installed a line specifically for the chemical separation of PA/PE composite films in Memmingen. Using this method and a suitable solvent, it will be possible to recover other raw materials as well. Image: Trenntechnik Ulm

of 57 per cent. In 2014, for example, 1.75 million tonnes of post-consumer PET wastes were collected. Here, again, the collection rates vary greatly. While Germany, Italy and Switzerland collect about half of the total volume, some countries achieve a collection rate of only 10 to 20 per cent. The PET sector is enjoying rising collection rates overall, which, according to PCI PET Packaging, Resins & Recycling Ltd., should increase by a further 3 to 5 per cent per year by 2019. However, it is almost exclusively bottles that are collected, usually in dedicated collection schemes. Although it was originally the goal to return the collected bottle flakes to bottle production, the industry has sought and found customers in other areas. For film/sheet manufacturers, post-consumer bottle flakes have become increasingly interesting, and in 2014 they used the biggest share – 34 per cent – of the collected residuals in their branch of industry. Almost 30 per cent of the flakes were used in blow moulding applications, 26 per cent in the fibre industry and the rest for packing straps and other products.

PVC recycling achieves high utilisation rates

The recycling of PVC, a material whose outstanding mechanical properties have made it indispensable – particularly in the building sector, where it has a 70 per cent share, but also in the packaging, furniture and medical technology segments – has developed very encouragingly in the last few years. According to a Consultic study commissioned by PlasticsEurope, the demand for PVC in Europe came to 4.9 million tonnes in 2014, making it the third most used plastic after PP and PE. Germany accounts for 1.56 million tonnes of this, or roughly a third of total demand. Since PVC is often employed in very durable products like windows, pipes and floorcoverings, “only” 650,000 tonnes are available for reutilisation each year,

with about 520,000 tonnes of this coming from post-consumer applications and 130,000 tonnes being industrial wastes. The reutilisation rate for PVC wastes is 99 per cent, with only 1 per cent being disposed of. Of the 99 per cent that is reutilised, 62 per cent, i.e. 396,000 tonnes, is used for energy recovery and the rest is recycled. The recycled PVC generated in this way is put to use particularly in building applications, e.g. in new profiles and pipes, as well as in horticulture and agriculture. “Our sector has been concerned with the recycling of PVC for over 25 years, so we already have a very well developed network today,” says Thomas Hülsmann, Managing Director of Arbeitsgemeinschaft PVC und Umwelt e.V., Bonn. At www.pvcrecyclingfinder.de, many PVC-processing companies are listed. Just how important recycling is for the sector is expressed by the European voluntary commitment that is supported by the leading plastics associations. In the most recent voluntary commitment “VinylPlus”, the companies of the sector undertake to reutilise 800,000 tonnes of wastes for recycling and energy recovery by 2020. This demonstrates the forward-looking and sustainable position adopted by the sector, Hülsmann adds.

Composites are often unsuitable for recycling

While post-consumer products made of pure polymers lend themselves well to reprocessing, the situation for composite products consisting of two or more raw materials is entirely different. These wastes are in most cases unsuitable for recycling. Dr Michael Scriba, mtm-plastics Managing Director and member of Plastics Recyclers Europe (PRE) and of Bundesverband Sekundärrohstoffe und Entsorgung [Federation for Secondary Resources and Disposal] (bvse), is therefore calling for the recycling-friendly design of the packages that contribute a large proportion



For many products, such as bin liners, it has already become commonplace today to use recycle. This makes good economic and ecological sense. Image: Polifilm

For the extrusion blow-moulded dishwashing detergent bottle made of polyethylene, Ecover Belgium N.V., manufacturer of ecological cleaning agents, uses plastic wastes gathered by fisherman from the sea. Image: Ecover



of post-consumer wastes. With the aid of the RecyClass (www.recyclclass.eu) programme, any manufacturer of plastics packages can quickly and easily check whether his package is recycling-friendly. Here it is particularly important to dispense with fillers like chalk in PE and PP packages as far as possible, avoid plastics-paper composites, use pigmentation in moderation and make sure that the density of all products is well clear of 1 g/cm^3 so that separation on the basis of density is possible.

At the same time, efforts are being made in the industry to develop reutilisation strategies for mixed wastes. Trenntechnik Ulm GmbH is pursuing a very exciting approach here in developing a chemical separation process for PE/PA composite films and building a unique production plant with a capacity of 10 tonnes per day. The end products of the separation process are a polyamide comparable with virgin material and a polyethylene that is pigmented directly with soot, i.e. a carbon black master batch in a particularly pure form. As stressed by Managing Director Wolfgang Zacherle, there is a suitable solvent and separation agent for every plastics composite, so there are no obstacles to an extension of this process to other composite products.

Summary

Although recycling is a much-discussed topic today and is also very much alive in many projects in the plastics industry, experts are repeatedly confirming that, by comparison with other sectors, too little waste material is used instead of virgin material. Across Europe, 50 per cent of metal scrap is returned to the steelmaking process, and the same applies to the paper industry, where 50 per cent of old paper and board is used in the production of new paper and board. For glass, at 33 per cent, the figure is a

little lower, but still very high compared to the quantities that are recycled in the plastics sector. For in the plastics sector, only about 4 per cent of reprocessed waste plastics are used instead of virgin material in the fabrication of plastics products. The plastics sector is of course a young industry overall. Plastics only became widespread in the 1950s, and reutilisation strategies for waste plastics were only introduced in 1990s, yet both the collection systems and technical feasibility have developed enormously in the intervening period. Anyone wishing to find out about these new technical solutions can do so at K 2016, the world's No. 1 trade fair for the plastics and rubber industry, from 19 to 26 October in Düsseldorf. Numerous exhibitors are presenting machines and plant for processing and recycling, for pure-grade wastes as well as for mixed wastes and wastes of rubber.

It can therefore be assumed that recycling rates will continue to rise in the years to come, as there is strong demand for recycle for both environmental and economic reasons. Marine litter, i.e. the pollution of the seas with wastes, has internationally highlighted the irresponsible treatment of wastes particularly in newly industrialised countries and lent added strength to the demands of other consumers for the sustainable treatment of resources. Model projects like the Ocean Bottle are not only very interesting examples, but also help to raise awareness of the subject among the general public and, above all, consumers. For the production of this Ocean Bottle, Ecover Belgium N.V. enlisted the services of fishermen in Britain, France and Belgium to collect bottles from the sea. 10 tonnes of waste was accumulated within a year, and the PE fraction from this was recycled into new PE dishwashing detergent bottles.



VM VERLAG/Germany presents:

Four specialized trade magazines
for plastics processing worldwide,
Far East, CIS-States and Europe.



For more information:

**VM VERLAG GMBH
KÖLN · GERMANY**

Eggenstein Branch

P.O.Box 12 60 · 76339 Eggenstein-Leopoldshafen/Germany

Tel. +49/721/700 626 · Fax +49/721/62 71 02 66 · e-mail: i.boehle@vm-verlag.com

www.extrusion-info.com