

06/2021

VM VERLAG
Cologne /Germany

EXTRUSION INTERNATIONAL



Big diameter pipe extrusion for
water, sewage and mining applications.
www.battenfeld.cincinnati.com

Process engineering for
efficient plastics extrusion of
tomorrow.

battenfeld-cincinnati 

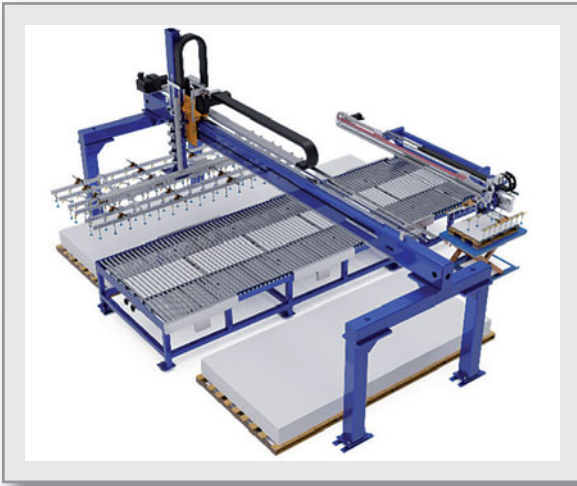
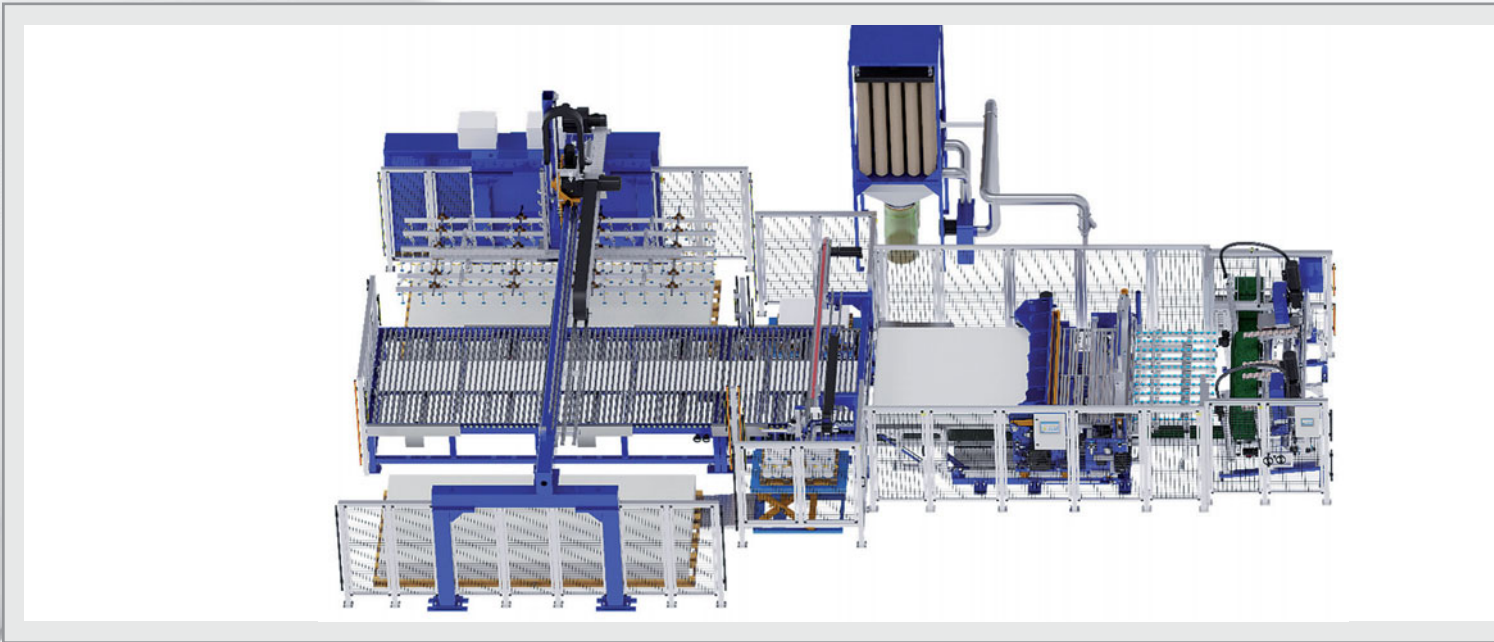

Plate Stacking Machine

for automatic depositing of your production plates on transport pallets or trolleys.

Optional available with:

- Additional stacking places
- Spreading device of sheets side by side
- Separation of consecutive panels for simultaneous stacking



Cross Cutting Combination

enables optional sawing or cutting in one machine.

Optional available with:

- Hydraulic driven scissor
- Electric driven scissor
- Cross Cut Mill instead of saw
- Cutting angle adjustment



Made in
Germany

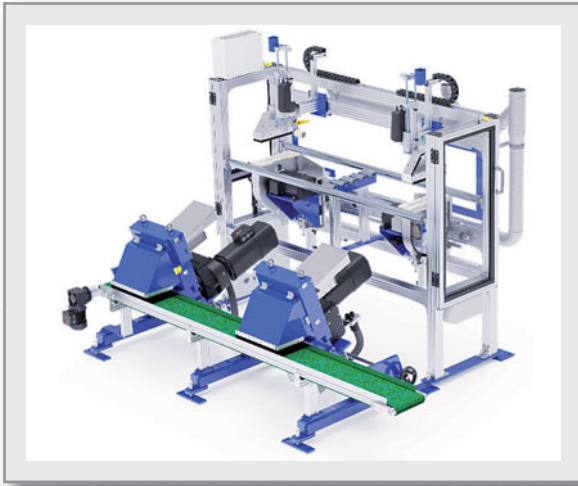

Edge Trimming Saw & Trim Strip Chopper

an unbeatable team for longitudinal cutting of your panel and direct shredding of the resulting return material.

The machines are also offered individually with many options.

As a specialist in the field of special machine construction, we always find a solution!



Pull Off Roller

provides precise regulation and compliance of roller speed and roller force.

Optional available with:

- Automatic material run control
- Selection of roller coatings
- Multiple Pull Off Roller version

Calender

for continuous dimensional accuracy and surface quality.

Key data:

- Throughput capacity depending on material 400 - 1300 kg/h
- Line speed 0,5 - 70 m/min
- Line pressure per roller: 100-1300 N/cm



**STEIN Maschinenbau
GmbH & Co. KG**

Wartbachstrasse 9
66999 Hinterweidenthal/Germany
Tel. (+49) (0)63 96-9215-0
Fax (+49) (0)63 96-9215-25
stein@stein-maschinenbau.de
www.stein-maschinenbau.de

Firms in this issue	6	Medical-Grade TPE Film for Wound Healing Applications Developed	30
Imprint	7	Sales Partnership for Switzerland	30
Industry News	8	Portfolio of High-Performance Light Stabilizers Expanded	31
Calendar	8	Activities in Mexico Expanded	31
New 1200 mm Line is Put Into Operation	8	Range of Food Contact TPEs Extended	32
Chinaplas 2022: Plastics Industry's Efforts to Comply with China's „Dual Carbon“ Targets	9	Flame Protection Activities in Europe Strengthened	32
Renewable Materials Conference	10	HDPE Recycling Plant in Mexico Starts Operation	33
Expansion of Cooperation	10	Production of Polymer Compounds in Turkey	33
Market Study: Plastic Pipes – Europe	11	Investment in Sustainable Production and Solutions	34
AMAPLAST Assembly	12	Certifications as Reusable Materials in the Recycling Stream	35
Acquisition	13	New Universal Control Unit	35
Global Plastics Ranking™: China, the U.S., and Germany Lead	14	Extrusion Technology	
New Management in France	15	Small and Flexible – Alpha Plus Extruders for Roller Blind Producer	36
27th Fakuma 2021 – Inspiring Plastics Live!	16	Measuring Technology – Case Study	
Celebrating 70 Years of Innovation	17	„The PURITY SCANNER ADVANCED is used where other sorting systems have difficulties“	38
New Subsidiary in Poland	18	Quality Control	
7th International RePlast	18	Quality Control Made Easy	40
Highest Standards of Quality Control Solutions Presented at the Arabplast	19	Recycling	
PLASTPOL – The Plastics Industry Keeps Going from Strength to Strength	20	100% rHDPE – FDA Gives Green Light for Recycling Process	41
New Flake Sorting Test Center in Italy	20	Economical Solutions for Plastics Technology	
Production Plant to Poland	22	„Efficiency meets Sustainability“	42
Forces on Renewable Raw Materials for Plastics Production Joined	22	Film Extrusion	
Award – Recycling Machinery Innovation of the Year	23	Ultimate Product Protection, Especially Sustainable	44
Market Study: Polyvinyl Chloride	23	Recycling	
Acquisition	24	Complete Process Solutions for Recycling Technology to Test Center Added	45
Upgrading Plastic Waste into Valuable Products	24	Recycling	
Cooperation	25	„PRT Targu Mures“ Joints Venture Promotes a Bottle-to-Bottle Cycle	46
Presence in Asia Expanded	26	Company Anniversary – Interview	
Green Packaging Star Award	26	Celebrating 70 Years of a Family Business	48
In-House Rheology Lab launched	27	Packaging Film, Recycling	
Low-Leakage Couplers	27	Pioneering Proof of Concept to Help Close the Loop for Digitally Printed Pouches	50
PET Solution for 100% PCR Use in Direct Food Contact Exhibited	28		
New 500 Series Rubber/Silicone Extrusion Crosshead	28		
European Bioeconomy Robust	29		



41 In August 2021 Starlinger & Co GmbH received two Letters of No Objection (LNO) issued by the US Food and Drug Administration FDA regarding its newly developed machine concept for processing post-consumer HDPE scrap



BHS-Sonthofen has expanded its test center at the Sonthofen, Germany, site and has undergone modernization work in the areas of recycling and environmental technology **45**



The solutions presented by KraussMaffei at the Fakuma 2021 were all under the motto **42** "Efficiency meets sustainability" and have a clear focus on maximizing output, high product quality, reducing life cycle costs and ensuring sustainability



46 The ALPLA Group is investing in the construction of a recycling plant in Targu Mures, Romania as part of a joint venture with its partners. The plastic granulate recycled there in the future will come from PET bottles collected from household waste and will be used to manufacture new PET bottles

38 Since March 2021, SORTCO has been using two PURITY SCANNER ADVANCED systems from SIKORA in its new sorting service center in Niederzissen, Germany. With these, the pellets to be sorted are inspected 100 % optically and impurities from a size of 50 µm are automatically sorted out

At CHINAPLAS 2022, the highly efficient machines, recycling technologies and other production techniques that will help plastics manufacturers achieve their goals of reducing their carbon emissions are among the highlights **9**



Index of Advertisers, companies and *fairs* referred in this issue

Adsale	9, Outside Back Cover	Meusburger	27
ALPLA	24, 33, 46	MOLECOR	13
AMAPLAST	12	Mondi	26
A Più	12	motan-colortronic	7
APR	35	MTI	19
BASF	25	Nordmann	32
battenfeld-cincinnati	Outside Cover, 36	nova-Institut	10, 29
BHS-Sonthofen	45	OCS	19
BIC	29	Pfeiffer Vacuum	35
Biesterfeld	26	Pixargus	39
Brückner	10	PLASTICS	14
Busch Vacuum	24	PLASTPOL	20
CCA	13	Reifenhäuser	28, 50
Ceresana	11, 23	RePlast	18
<i>Chinaplas</i>	9	RKW	34, 44
Coperion	10	Schall, P.E.	16
EREMA	23	SIKORA	18, 38
<i>Fakuma 2021</i>	16	Smart-Extrusion	47
FEDDEM	22	Starlinger recycling tech.	41
GME Chemicals	26	Stein Maschinenbau	Inside Front Cover+3
GRAFE	30	Sumika	33
Guill	17, 27, 28	Targi Kielce	20
Impervious	30	TOMRA	20
iNOEX	8	TOPAS	35
<i>interplastica 2022</i>	37	UniteChem	31
Kautex	31	USP	30
Kraiburg TPE	32	Vetaphone	17, 48
KraussMaffei	15, 42	VM Verlag	Inside Back Cover
KÜNDIG	15, 40	WPO Polymers	25
Lanxess	22	Zeppelin	19
Lesun	21	Zumbach	11



**Follow the news
in the world
of extrusion!**

Subscribe to digital magazines
and Smart Extrusion weekly newsletter

- **Just** submit your **e-mail address**.
- Digital magazines and news updates **free of charge**
- No spam. Your data is safe



www.extrusion-info.com/subscription

06/2021

VM VERLAG
Cologne / Germany

EXTRUSION INTERNATIONAL



The Extrusion International Magazine is published bimonthly by VM Verlag GmbH. P.O.Box 501812, D- 50879 Cologne, Germany

EDITORS

Bettina Jopp-Witt (Editor-in-chief)
Tel. +49 221 546 1539
redaktion@vm-verlag.com

Dmitry Kosuch
Tel. +7 996 730 0113
d.kosuch@vm-verlag.com

ADVERTISING SALES

Martina Lerner
Tel.+49 6226 971515
lerner-media@t-online.de

Bella Eidlin
Tel. +49 152 29907895
b.eidlin@vm-verlag.com

Olga Kirchner
Tel. +49 152 05626122
o.kirchner@vm-verlag.com

ADMINISTRATION

Alla Kravets
Tel. +49 2233 949 8793
a.kravets@vm-verlag.com

PRINTING

maincontor GmbH
Dr.-Gammert-Str. 13a, 63906 Erlenbach, Germany
T.: +49 937294810811
www.maincontor.de, info@frankhohmann.com

SALES REPRESENTATIVES

Quaini Pubblicita (Milano IT)
Tel. +39 02 39216180
info@quaini-pubblicita.it

China & Asia
octavia@ringier.com.hk, Tel. +852-9648-2561
maggieliu@ringiertrade.com, Tel. +86-13602785446

Tokyo PR Inc. (Japan)
Tel. +81 (3) 3273-2731
extrusion@tokyopr.co.jp

Reprints, Translation etc

No part of this publication may be reproduced, stored in a retrieval system, or transmitted, in any form or by any means, electronic, mechanical, photographic, recording or otherwise, without prior permission of the publisher.



www.smart-extrusion.com

motan® 
colortronic®

Perfect and constant dosing

 think materials management



Please visit us:
25-28 January 2022,
Hall 2, Booth 3A05



SPECTROPLUS

A dosing unit for all extrusion and compounding tasks.

motan-colortronic gmbh - info@motan-colortronic.de
www.motan-colortronic.com



OMANPLAST

25. - 27. 01. 2022
www.omanplast.com

Solids Dortmund

16. - 17. 02. 2022
Dortmund, Germany
www.solids-dortmund.de

bio!PAC

15. - 16. 03. 2022
Düsseldorf, Germany (Hybrid)
www.bio-pac.info

ICE Europe

15. - 17. 03. 2022
Munich, Germany
www.ice-x.com/europe

12th European Thermoforming Conference

31. 03. – 01. 04. 2022
Vienna, Austria
www.thermoforming-europe.org

Plastasia 2022

20. – 23. April 2022
New Delhi, India

CHINAPLAS 2022

25. - 28. 04. 2022
Shanghai, P.R. China
www.ChinaplasOnline.com

COLOMBIAPLAST

26. - 30. 09. 2022
Bogotá, Colombia
www.eng.colombiaplast.org

wire South America TUBOTECH

25. – 27. 10. 2022
www.wire-south-america.com
www.tubotech-online.com

INDIA ESSEN WELDING & CUTTING 2021

23. - 25. 11. 2022
Bombay, India
www.india-essen-welding-cutting.com

New 1200 mm Line Is Put Into Operation

■ Shandong Shengbang Plastic Co. Ltd., which was founded in 1994, is one of the earliest PE pipe manufacturers in China with two big production sites in Dongying and Xian. All of Shengbang's extrusion lines are from Battenfeld and Krauss Maffei, equipped with iNOEX systems. Shengbang can produce pipes and supporting fittings of all specifications of dn20mm-dn1200mm with an annual production capacity of 150.000 tons. After years of good operation and healthy development „Shengbang“ brand has become a symbol of high quality in China's PE pipeline field.

The newly purchased 1200 mm large-diameter line was successfully put into operation on August 17th. This new line is equipped with the german iNOEX gravimetric system and an iNOEX WARP 1200 inline measurement system to ensure high efficiency and stable quality of the produced pipe.

The new line can produce DN630-DN1200 PE solid wall pipes with an annual capacity of 10000 tons. With new production line, Shengbang will be able to independently produce DN20-DN1200 PE pipes with the highest standards of quality while, thanks to the iNOEX systems, saving money, time and material.

New Sales Office in Dubai

In addition, iNOEX is expanding its presence in plastics extrusion in the Middle East. This expansion is part of iNOEX's strategy to improve its own position in the market as a global supplier of pioneering measurement and control technology for pipes, tubes, cables, films and profiles.

For many years, iNOEX is a supplier for leading pipe manufacturers in the Middle East and now also operates with its own representative office in the United Arab Emirates. The Dubai office was officially opened on 15th November by Jan Lohoff, Managing Director of iNOEX GmbH in Melle, Germany, and Miguel Izquierdo Blanco, Director Sales of iNOEX GmbH. From Dubai, iNOEX Middle East will supply the UAE, Bahrain, Qatar, Saudi Arabia, Oman, Jordan, Lebanon, Kuwait, Libya and Egypt with high-quality solutions and systems for measurement and control technology. The local sales responsibility will be taken over by Mohamed Abdou, who has more than 15 years of experience in the plastics extrusion industry. As a B.E. Electronics & Communication Engineering, he is very familiar with the technical requirements as well as the needs of our customers.

„Our new sales office in Dubai puts us in a position to communicate more closely with our customers in the UAE and countries in the region, as well as react to local market needs,“ says Jan Lohoff, Managing Director of iNOEX GmbH. „Dubai has increased in importance as a location for plastics extrusion in recent years. Therefore, the new office is an ideal starting point to sustainably expand sales in this region and our own presence,“ adds Lohoff.

iNOEX WARP 1200 measuring system on Shengbang's PE pipe extrusion line



► iNOEX GmbH
www.inoex.de

Jan Lohoff (Managing Director, iNOEX GmbH; right), Miguel Izquierdo Blanco (Director Sales, iNOEX GmbH; left) and Mohamed Abdou (Senior Sales Manager, iNOEX GmbH, mid) (Copyright: iNOEX GmbH)



Chinaplas 2022: Plastics Industry's Efforts to Comply with China's "Dual Carbon" Targets

April 25-28, 2022, Shanghai, PR China

■ China has embarked on a road towards a "dual carbon" target where it commits to reach its carbon peak by 2030 and move forward to achieve carbon neutrality by 2060. As the world raised concerns over climate change, countries are exerting efforts and directing resources to curb carbon and greenhouse gas emissions. Having the world's biggest industrial production, China's role in meeting its "dual carbon" goal is crucial and its commitment has been well received around the world.

To reach its "dual carbon" goal, China has introduced policies encouraging technological innovations that are aimed at encouraging smart production, utilizing renewable energy, increasing recycling and usage of bio-based and recycled materials. More investments have also been directed towards "green manufacturing" projects as green manufacturing is one of the strategic objectives under the 'Made in China 2025' plan. The government has also been supporting some industries that have shifted to products that contribute to reduction in carbon emission, such as the production of new energy vehicles (NEV) like electric vehicles.

China's plastics manufacturing operations are largely dependent on fossil fuels, hence carbon emissions from these plants remain high. A report from the WWF Global states that in 2021, researchers estimate that the production and incineration of plastics will amount to over 850 million tons of greenhouse gases into the atmosphere. As plastics factories resume their production following the pandemic, emissions from these factories have surged.

But the commitment of the plastics industry has not waned and will continue to inspire innovations and development of state-of-the-art technologies to reduce their carbon footprints. Given that each stage of plastics production produces greenhouse gas emissions that affects the environment, a growing number of companies in the



DSM Engineering Materials accelerates its carbon footprint and greenhouse gas emission reduction program (Image source: DSM)



plastics industry are taking urgent steps to reduce their carbon footprint, either through the use of more efficient and smarter production process, shift towards renewable energy such as solar energy to power their plants, plastics recycling and re-use of recycled materials as inputs. Leading global companies are supporting China's goal to reduce carbon emissions.

At CHINAPLAS 2022, the highly efficient machines, recycling technologies and other production techniques that will help plastics manufacturers achieve their goals of reducing their carbon emissions are among the highlights. On-floor demonstrations of well-known Chinese and overseas exhibitors, and consultations with technical experts will further help visitors as they explore viable options.

A fully recyclable ABS grade containing 50% of recycled post-consumer waste electrical and electronic equipment (WEEE), developed by INEOS Styrolution, is applied to produce travel luggage (Image source: TUPLUS)



Renewable Materials Conference

10–12 May 2022, Cologne, Germany, hybrid

■ The unique concept of presenting all renewable material solutions at one event hits the mark: bio-based, CO₂-based and recycled are the only alternatives to fossil-based chemicals and materials.

Ready-to-use fossil-free sustainable material solutions with a low carbon footprint are in fast-growing demand. Innovative brand owners are keeping an eye out for such solutions, in particular those that will soon reach the mainstream.

For the second time, nova-Institute presents numerous market highlights from bio- and CO₂-based chemicals and materials as well as from chemical recycling: All material solutions based on renewable carbon. Together, there is sufficient potential to completely replace petrochemicals by 2050. To tackle climate change at its roots, all additional fossil carbon from the ground must be substituted with renewable alternatives. Over the course of three days, participants will get a comprehensive overview of the latest developments in the renewable material sector, with a focus on industry-ready solutions from a wide spectrum of sustainable raw materials and technologies.

Innovation Award “Renewable Material of the Year 2022”: To showcase the vast spectrum of renewable materials, the innovation award “Renewable Material of the Year 2022” will be chosen and awarded during the conference. Find all information and the submission deadlines for the innovation award here: www.renewable-materials.eu/award-application

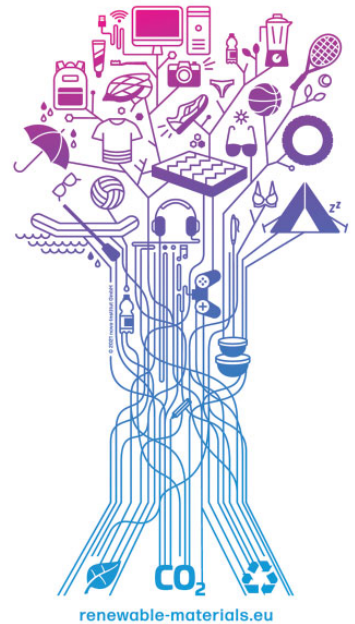

■ nova-Institut GmbH
www.nova-institut.eu
www.renewable-materials.eu

Expansion of Cooperation

■ Brückner Maschinenbau has placed an order with Coperion for more than 50 ZSK Mc18 twin screw extruders. These will be integrated into plants for the production of flexible BOPET packaging films, which Brückner will install in China. The ZSK extruders have screw diameters ranging from 70 to 177 mm.

Plastic film stretching line from Brückner Maschinenbau, in which ZSK extruders from Coperion take over the melting of the compounds (Image: Brückner Maschinenbau)



Brückner Maschinenbau’s substantial repeat order is based on many years of close cooperation with Coperion. With this order, Brückner is once again putting their trust in proven Coperion technology, which the company has already integrated into numerous film stretching lines. The ZSK extruders are used to melt the compounds that are fed into the lines. Thanks to their high torque, Coperion’s ZSK Mc18 extruders achieve very high throughput rates while maintaining low product temperatures and thus ensuring first-class product quality.

“We are very pleased that Brückner Maschinenbau is once again relying on our technology and know-how,” says Jochen Schofer, Business Segment Manager Recycling & Direct Extrusion at Coperion. “We very much appreciate this familiar, long-standing cooperation with the pioneer for plastic film lines. Our companies pursue very similar aspirations. We both develop high-quality technologies for plastics production with very high throughput rates. The efficient use of resources and high recyclability of the end products are important to us.”

■ Coperion GmbH
www.coperion.com

Brückner Maschinenbau
www.brueckner-maschinenbau.com

Market Study: Plastic Pipes – Europe

■ The construction industry is flourishing in many European agglomerations. Manufacturers of plastic pipes are also benefiting from government economic stimulus programs to overcome the Corona crisis and the expansion of infrastructure. Regionally, however, the development varies greatly: while building materials are becoming scarce and expensive in parts of Germany and Poland, for example, the construction industry in Spain is still far from its former record levels. Ceresana is publishing a comprehensive report on the European market for plastic pipes for the fifth time already. The current new edition provides an assessment and quantification for the first years after the pandemic.

Current Market Data: Chapter 1 provides an overview of the European market for plastic pipes – including forecasts up to 2030. Key figures are given for revenues and demand, broken down by product types and applications.

In Chapter 2 specific market data are given for 30 European countries: In addition to revenues, import and export, production and demand volumes are also shown. The data on production and demand are broken down into the plastic types polyethylene (PE), polypropylene (PP), polyvinyl chloride (PVC) and other plastics. In addition, the demand for each country is divided into the individual application areas. Chapter 3 offers company profiles of the most important plastic pipe producers, clearly arranged by contact details, revenues, profit, product range, production sites and brief profile. Detailed profiles are provided by 77 manufacturers.

■ Ceresana
www.ceresana.com/en/market-studies/industry/plastic-pipes-europe/



Precision Wall Thickness Measurement

Zumbach
 SWISS PRIME MEASURING SINCE 1957

RAYEX S XT

- Easy and quick set up for new products
- Fast eccentricity and diameter measurement
- Added longevity due to high-quality xray source



Family owned since 1957, Zumbach is a global leader in the industry. Driven by innovation and experience. We are here for you and ready to build the future together.

www.zumbach.com • sales@zumbach.ch

AMAPLAST Assembly



■ Amaplast, the Italian national trade association of some 170 manufacturers of plastics and rubber processing machinery, equipment, and moulds, and a member of Confindustria, held its annual member assembly at 16 September 2021 at Milan.

During the assembly, the members confirmed President Dario Previero and the Vice Presidents Gabriele Caccia and Massimo Margaglione for the two-year term 2021-2023. In his address to the assembly, Previero illustrated the performance of the Italian plastics and rubber processing machinery industry, commenting on the results of the first edition of the National Statistics Survey by the MECS-Amoplast Statistical Study Centre among some 350 manufacturers (employing a total workforce of 13,000) that generated revenues of nearly 3.6 billion euros in 2020, of which 76% from exports.

While the industry closed the year 2020 with a negative balance, the deficit was not as bad as might have been feared after the complicated months of the pandemic. Instead, companies showed recovery in the final months of the year, boosted by growth in the first half of 2021. This confirms the solidity and dynamism of the industry. The outlook for the upcoming months is marked by optimism bolstered by the positive signals arriving from various markets and applications.

President Previero also reiterated the key themes faced by companies in the sector: from the expected reforms and support that will finally put the crisis behind us to ecological transition and from problems procuring materials, components, and qualified personnel to digital transformation and new post-pandemic business models.

In closing, the President commented on the complex issues relating to trade fairs and the path of synergy through association now fully implemented with ACIMAC (Association of Italian Manufacturers of Machinery and Equipment for Ceramics) and UCIMA (Italian Packaging Machinery Manufacturers Association).

Previero's address was followed by the round table discussion "Sustainability 4.0".

Trade Fairs:

Following the pandemic-induced upheaval in the world trade fair calendar, the service company Promaplast srl was forced to postpone the 2021 edition of PLAST, initially from May to June in the hopes of quick positive developments in the public health situation and then to a later year.

In light of responses gathered from major exhibitors and openings in the FieraMilano calendar, the decision was made to reschedule the fair to 5-8 September 2023, a year after K and with a reasonable interval after the major international fairs for the sector.

Six hundred exhibitors who were registered for PLAST 2021 have confirmed their participation in 2023 and have currently reserved 30,000 square metres of exhibition space.

In consideration of the big push for ecological transition embodied in the National Recovery and Resilience Plan (PNRR) and other instruments, Promaplast srl has announced a new event called GREENPLAST dedicated to environmental sustainability, energy efficiency, recovery-recycling-reuse, and the circular economy.

A showcase for the most advanced solutions in polymers, finished products, machinery, services, and much more. The fair will take place in Milan, 3-6 May 2022 in conjunction with Ipack-Ima, Print4All, Intralogistica Italia, and, for the first time in Milan, Pharmintech.

Round Table: "Sustainability 4.0":

The Amoplast assembly concluded with a round-table discussion titled "Sostenibilità 4.0", with contributions from Camillo Rovida, Amoplast consultant; Marco Versari, President of Consorzio Biorepack, Public Affairs Manager of Novamont spa, and former Assobioplastiche President; Walter Ganapini, Honorary Member of the Scientific Committee of the European Environment Agency, Co-founder of Legambiente, and former President of Greenpeace Italia; and Osvaldo Bosetti, Industrial Director of Europa Goglio spa.

President Previero closed the assembly underscoring that Italian manufacturers of plastics and rubber processing machinery are ready to embrace the new challenges as an impulse to develop increasingly advanced technological solutions.

Acquisition

■ On September 30, 2021, Molecor completed the process of acquiring the Adequa production unit (formerly Uralita Sistemas de Tuberías), thus complying with the provisions of the order of July 29, 2021 of the Commercial Court No. 12. After this acquisition, Molecor triples its previous turnover and becomes one of the leading companies in the pipeline market in Spain.

The plants in Spain of Getafe (Oriented PVC manufacturing technology and R&D headquarters) and Loeches (Oriented PVC pipes and fittings manufacturing), are now joined by those of Alovera (Guadalajara), Alcázar de San Juan (Ciudad Real) and Antequera (Málaga), thus adding to the Oriented PVC pipes and fittings that Molecor had been manufacturing, a wide portfolio of products:

- Building solutions (EVAC+, AR®, floor evacuation, gutter system, siphons)
- Solutions for sanitation and drainage (SANECOR® corrugated PVC sanitation, SANECOR® manholes, COMPACT SN4 smooth system, PVC drainage system)
- Supply and distribution (smooth pressure PVC, fittings for smooth PE pipes)

Molecor has developed a unique business model in the pipeline sector based on three fundamental pillars: innovation, internationalization and agility in decision-making, which has allowed it to achieve growth rates well above the sector even in recent tougher periods of crises, and an extraordinary international presence.

The efficient transport and management of water is one of the fundamental bases for progress and thus represents great business potential. With this acquisition, Molecor continues its growth process.

(Copyright © 2021 Molecor Tecnología S.L.)



Molecor continues with its growth process whose objective is to be a world leader in the sector and a benchmark of quality, efficiency and sustainability

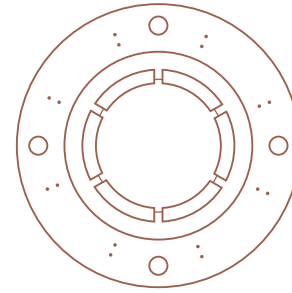

CCA
The Original

Innovation is our Passion

CCA offers different adjustable calibration sleeves to optimize your plastic pipe production – from 14 up to 2,600 mm pipe outside diameter.

Discover now the individual solution for your needs:

- conventional
- 2-point adjustment
- 1-point adjustment
- 4-point adjustment



Global Plastics Ranking™: China, the U.S., and Germany Lead

■ The Plastics Industry Association (PLASTICS) recently issued its 2021 Global Trend Report. This PLASTICS' flagship publication takes a deep dive into the U.S. plastics trade with the rest of the world during the previous year and the first six months of the current year. It also provides a snapshot of the international plastics and rubber trade. Additionally, it includes a plastics trade forecast. Moreover, starting in 2018, the report began including PLASTICS' Global Plastics Ranking™ – a ranking of the top-100 countries in the global plastics trade as determined by trade volume. It is also a measure of plastics intensity in each nation's economy. Countries' exports and imports of plastics resin, products, machinery, and molds are used as proxies of their production and consumption of plastics.

In 2020, China ranked first followed by the U.S. and Germany. These countries have retained the top three positions as the world's leaders in global plastics since the Global Plastics Ranking™ began. PLASTICS estimates China's 2020 plastics trade volume at \$180.2 billion. The plastics trade volume of the U.S. and Germany are estimated at \$129.6 and \$110.9 billion, respectively. The U.S., however, ranked third after Germany in 2018. But in the last two years, it has overtaken Germany.

Considering that plastics is a mature industry, its growth will track economic output growth measured in gross domestic product or GDP. For this reason, it is not unusual to see the world's strongest economies as key players in the global plastics trade.

As China's economy expanded so did its industrial sector, which includes plastics. China's GDP growth averaged 8.7% from 2001 to 2020. Over that period, the global share of China's exports of plastics and products thereof – as broadly classified under the Harmonized Tariff Schedule (HTS) 39 – has grown significantly from 4.0% in 2001 to 16% in 2020. With a growing middle class, it is expected that consumption would be a higher share of China's GDP in the coming years. This means higher growth for production and imports of plastics. China's share of world imports of plastics has increased from 8% in 2001 to 11% in 2020.

While the U.S. economic growth between 2001 to 2020 averaged 1.7%, it remains the world's largest consumer of goods manufactured from other countries. 70% of U.S. GDP is consumption. The U.S. share of world plastics imports (HTS 39) has remained stable at around 10% from 2001 to 2020. Its export share of plastics (HTS 39) decreased from 14% to 10% over the same period. As a \$19.0 trillion-plus economy, it is expected that the U.S. will remain a key player in the global plastics industry.

Germany's role in the global plastics industry is anchored on innovations in plastics machinery and engineered resins. Its manufacturing sector is replete with opportunities for new products and new applications for plastics. For this reason, alongside a growing economy, Germany's role in the global

plastics trade will remain significant. PLASTICS estimates Germany's 2020 plastics trade volume at \$110.9 billion. Like the U.S., Germany's share of global plastics exports decreased from 13% in 2001 to 11% in 2020. Its share of global plastics imports

has averaged 7.3% between 2001 and 2020 - with a high of 8.0% in 2008 and a low of 6.9% in 2004. Compared to the U.S., the percentage of consumption in Germany's GDP is low at 49.5% in Q2 2021 and 50.9% for a Q2 2020.

In the global plastics trade, trade agreements matter for the U.S. Its largest plastics trade partners are Mexico and Canada. All three economies have benefited from U.S.-Mexico-Canada trade agreements, beginning in 1992 with the North American Free Trade Agreement (NAFTA) and now with the United States-Mexico-Canada Agreement (USMCA). Last year, Mexico and Canada were up a notch from 2019 in the Global Plastics Ranking™. Both countries made it in the top ten with Mexico in the 9th and Canada in the 10th spot. We estimate the plastics trade volume in Mexico and Canada at \$33.5 and \$30.9 billion, respectively. The economies of USMCA partners are projected to improve this year and the next. Considering that the manufacturing value chains of these countries are linked, it can be expected that the plastics trade among the three free trade partners will rise.

There are up-and-coming global players in Global Plastics Ranking™. One of which is Vietnam. In 2020, Vietnam was ranked 16th – up from 20th in 2019. Vietnam's plastics trade volume rose to \$22.4 billion as exports strengthened due to its labor cost advantage over other countries. India dropped to 19th from 16th in 2019. And Turkey completes the top-20 countries replacing Saudi Arabia.

As discussed in the 2021 Global Trends Report, the key players in the global plastics trade will continue to face challenges on different fronts. But it is obvious from the rise of other countries into the global plastics ranking that global plastics demand has been and is expected to remain healthy considering its cost-advantages over other materials and many applications across manufacturing and service industries.

The Global Plastics Ranking™ was trademarked by Perc Pineda, PhD for the Plastics Industry Association.



■ The Plastics Industry Association (PLASTICS)
plasticsindustry.org

New Management in France

■ Christophe Longuet has taken over management of the KraussMaffei business in France. Effective January 1, 2022, Longuet will take the helm of KraussMaffei Group France S.A.S. as President. His predecessor Jacques Socquet will focus on the NETSTAL business in France with immediate effect and take over management of the newly established NETSTAL company in France as of January 1, 2022. NETSTAL returned to operating independently within the KraussMaffei Group in October 2021.

Tobias Daniel, Vice President Sales New Machines and Chairman of the Board of Directors KraussMaffei France, says: "This is an important milestone for our strategy, which will consolidate KraussMaffei as a first-class solution provider for the plastics and rubber industry in France. By strengthening our French team, we will ensure a first-class customer experience throughout the lifecycle. Under Longuet's leadership, all sales and service activities for the entire KraussMaffei portfolio, including injection molding, extrusion and reaction process machinery, will now be bundled in France and the resulting synergies will be further exploited." Davide Pagliarulo, Director Sales New Machines Western Europe, confirms, "We are delighted to welcome Christophe to our



From left to right: Benjamin Albrecht (Head of Area Manager Service West Europe/Africa), Christophe Longuet (President KraussMaffei Group France), Tobias Daniel (Vice President Sales New Machines, Chairman Board of Directors KraussMaffei France), Davide Pagliarulo (Sales Director West Europe New Machines)

company and are optimistic about our future joint steps towards further growth in France."

■ KraussMaffei Group France S.A.S.
www.kraussmaffei.com

Quality control made easy

Check the quality of extruded films easily and efficiently

- Thickness profile
- Square meter weight
- Harmonic analysis
- Sheet weight (ISO 4591)

The Filmtest 3G does all this and more - in a single measurement pass - easy

www.gauge.ch



KÜNDIG CONTROL SYSTEMS

The Gauge Manufacturer for Film Extrusion  SWISS MADE

27th Fakuma 2021 – Inspiring Plastics Live!



■ Fakuma international trade fair for plastics processing celebrated an inspiring restart in Friedrichshafen from the 12th through the 16th of October, 2021. 1470 exhibitors from 39 countries came to Lake Constance for the first major international on-site event for the plastics industry this fall, and presented injection moulding, extrusion technology, thermoforming and 3D printing on a world-class level. Overall emphasis was placed on the issues of sustainability, circular economy and recycling.

“We’re back! Finally an on-site trade fair again with innovations you can actually handle!” This is what everyone was saying at this year’s Fakuma in the exhibition halls in Friedrichshafen. After the compulsory one-year hiatus, the event was held live again. The exhibitors showcased their innovations on 85,000 square metres of overall exhibition floor space. The fact that 40% of the exhibitors came from outside of Germany substantiates Fakuma’s great significance all over the world, especially in these exceptional times: “For the companies in our industry sector, Fakuma is one of the most important industrial trade fairs of all,” notes Annemarie Schur, Fakuma project manager at trade fair promoters P. E. Schall. “Fakuma was even more important this year. On the one hand because on-site trade fairs only became possible again in the fall of 2021, and on the other hand because the issues of environmental protection, circular economy and sustainability are an enormous task that we all have to tackle.” This is why Fakuma 2021 also set itself the goal of making a significant contribution to pioneering, forward-looking solutions. “Now we want to look forward to the future together,” said Bettina Schall, trade fair organiser and managing director of P. E. Schall GmbH & Co. KG. “Fakuma is the ideal platform for tackling the current challenges faced by the industry. Record figures and superlatives don’t matter this fall. The only thing that counts is that we all cooperate to get this restart going and carry on with our work.”

“I’m delighted that something like this is possible again,” said Prof. Dr.-Ing. Martin Bastian, Institute director of the SKZ in

Würzburg, at the trade fair’s opening ceremony. In his technical presentation to an auditorium full of trade press and guest listeners, he pointed out impressively what needs to be done in the industry: “We have to take more responsibility for what happens with plastic.” Martin Bastian made a passionate plea for the cause of plastics: “We have to ensure that plastic isn’t just accepted, but rather used with enthusiasm as well. And we have to do a lot more to educate people about its benefits,” says Bastian. “We have to be present in the schools and kindergartens and make it clear that the energy transition will never be possible without plastics.” The plea voiced by Dr Thomas Probst, keynote speaker of the German Federal Association for Secondary Raw Materials and Waste Management (Bundesverband Sekundärrohstoffe und Entsorgung), who offered an exclusive look behind the scenes of the recycling industry and spoke about hurdles and difficulties in recycling, was no less emphatic. “As perceived in general, plastics are not understood,” is the insight he arrives at.

The exhibition halls in Friedrichshafen were very well frequented right from the first day of the event. Interested expert visitors were able to gain an impression of the latest developments and perspectives for concrete solutions in the field of plastics processing. “Many tradition-rich global market leaders have made use of the crisis to advance their innovations.

The trend towards digitalisation is accelerating. Cross-company concepts have been developed for the establishment of a circular economy for plastic products. Every crisis presents opportunities too, and many a clever mind is taking advantage of them,” confirms Sandra Füllsack as well, managing director of Motan Holding GmbH and spokesperson for the Fakuma exhibitor advisory committee. “As a business platform for innovations throughout the value-added chain, Fakuma 2021 was once again the ideal venue for presenting new products and technological solutions, as well as for discussing trendsetting issues.” Extremely practical and with high levels of professional competence, and at the same time in a friendly atmosphere – this is how exhibitors and expert visitors regard this industry event. The next international trade fair for plastics processing, namely the 28th Fakuma, will take place from the 17th through the 21st of October, 2023.



Celebrating 70 Years of Innovation



Vetaphone staff from around the world gathered at the company's HQ in Denmark to celebrate the 70th Anniversary on 1st November

■ Vetaphone A/S, the inventor of corona treatment, is celebrating its 70th anniversary in 2021, and continues to pioneer the market for surface treatment under the Eisby family management.

It was the advent of plastic packaging materials in the years following the Second World War that led to the invention of a surface treatment that has become known globally as corona. In his small home workshop in Denmark, Verner Eisby set about solving the problem of getting ink to adhere to non-absorbent plastic film. Today, the company he established is managed by his two sons, Frank and Jan, and supplies cutting edge surface treatment technology to leading OEMs, converters, and extruders around the world.

CEO Frank Eisby explained: "My Father could not have known what his invention would grow into – today, corona treatment is a universal process that spans many industries across all continents, and without it the whole sector of flexible packaging would not exist – that's an incredible legacy and one that we are very proud of."

What Eisby discovered in 1951 was that the key to adhesion is all to do with surface tension and the relative values between the liquid being applied and the non-absorbent substrate being used. In modifying the surface tension of the substrate by applying a precisely controlled electronic discharge at close range, the chemical structure can be altered to allow the liquid to bond securely and avoid the risk of 'smudging'.

While the principle behind the process is simple science, the development of the technology required is ongoing, as new

and complex substrates are introduced into the market and innovative techniques are demanded by brand owners to enhance the appearance of their packaged products. In more recent times, this has led Vetaphone to develop plasma surface treatment, which is not a replacement for corona, but a more advanced application of the same scientific principles. Today, the company is a global enterprise, employing around 80 people at its high-tech headquarters in Kolding and around the world, and is represented in more than 60 different countries. The pioneering spirit is still intrinsic to the company's DNA, which is highlighted by the recent opening of a fully equipped showroom facility for in-person and online demos that complements its unique Test Lab facility that was launched in 2020. Company CSO Jan Eisby commented: "We are very proud of our unique heritage and will use our unrivalled knowledge and expertise to innovate surface treatment technology that meets the ever-changing needs of a vibrant marketplace. Vetaphone was the first and remains the foremost in this sector, and our future plans are designed to increase the market's understanding of the science behind the technology."

Read more on page 48.

► Vetaphone A/S
www.vetaphone.com

From the Simple to the Sublime



Series 800 crosshead for two to six layers



The latest generation of the **Series 800 crosshead** is designed to run two to six layer extrusions for high quality, high accuracy 1/8" to 6" OD tubing for medical, automotive, appliance and industrial applications.

Ideal for fluoropolymer multi-lumen, multi-layer tubing for fuel lines or thin layer combinations of polymers and adhesives to 0.02mm or less.

Features patented **Guill Feather Touch®** concentricity adjustment to eliminate leaking.

Please visit www.guill.com



10 Pike Street
 West Warwick, RI 02893
 USA
sales@guill.com Attention: Bill Conley

New Subsidiary in Poland

■ SIKORA has expanded its presence in Europe by establishing the new subsidiary SIKORA POLAND, in Lodz. The new office brings SIKORA's worldwide presence to 15 subsidiaries.

Dr. Jörg Wissdorf, member of the board at SIKORA, explains the decision to open the subsidiary with the great potential that the Polish market offers in the areas of tube and hose as well as plastics. "For example, there are many hose and tube manufacturers in the field of building services, infrastructure as well as automotive and industrial applications, which focus on innovative measuring technologies for best product quality, optimal processes and highest economic efficiency. These manufacturers will significantly benefit from our local customer proximity through timely and efficient support in the local language."

Director of the subsidiary SIKORA POLAND is Jacek Lewandowski. Lewandowski has many years of sales experience in different industrial sectors, among others in measurement technology. The graduated engineer with a master's degree in management and organization is initially the contact person for customers in the hose and tube industry.

In addition to Poland, Jacek Lewandowski is also responsible for the Baltic States Estonia, Latvia and Lithuania as well as



Jacek Lewandowski is director of the subsidiary SIKORA POLAND

the southeast European countries of Bosnia and Herzegovina, Bulgaria, Croatia, Kosovo, North Macedonia, Montenegro, Serbia, Slovakia, and Slovenia.

■ SIKORA Poland Sp. z o.o.
sales@sikora-poland.com

7th International RePlast

■ From September 21 to 22, 2021 the Cosmos Hotel in Moscow hosted the 7th International Conference "RePlast. Advanced Plastics Recycling Technologies" which was attended by 150 experts working along the chain of polymer processing. The event was organized by the magazines Extrusion and Plastiks with the support of the Interplastica exhibition. The speeches were presented by the experts and managers of SIBUR PolyLab, NGR, Politekprom, Europolymer-Trading,

Krauss-Maffei Extrusion, Aleko Machinery, BASF, Stanko-PET-RUS, Okapol, Gamma Meccanica (Avex Group Holdings), KGD, AtlasMash, Piovan, Recyclene, Aditim, Midaus. The speakers talked about advanced machinery for waste sorting, washing, grinding, filtration and granulation and about new additives which allow to improve the quality of recycled materials. The discussed issues included current immaturity of the market for recycled polymers, difficulties with introduction of chemical recycling technologies, use of biodegradation-promoting additives, limitations of waste recycling.

As was stated by many participants the RePlast-2021 Conference became a unique platform which is seemingly dedicated to rather narrow sector, but actually covers a wide range of pressing issues in the recycling industry. The attendees had the opportunity to exchange opinions on the sidelines of the conference, ask questions during the sessions and comment on the speeches, all of which proved the necessity of such a platform for experts of the field.

The next RePlast Conference will be held from 13 to 14 September, 2022. The organizing committee is planning to dedicate more time to discussions and as always offer to the attendees the most cutting-edge information delivered by the best experts in the recycling industry sector.

■ replast.extrusion-info.com



Highest Standards of Quality Control Solutions Presented at the Arabplast

■ OCS presented itself with expert solutions for quality control and assurance at this year's Arabplast in Dubai, UAE, in November.

100 per cent material purity – these are the buzzwords to attend. Particularly when it comes to highly complicated production processes, as is the case with medical applications or the production of high-quality compounds, absolutely flawless raw materials are essential. With OCS devices you can find every raw material defect and every irregularity that appears. For this purpose, they are equipped with innovative camera technology and special lighting systems. Furthermore, they are individually adapted to the requirements of



OCS Powder Tester PT2C with integrated Multi Hopper System MHS



OCS MHS Detail

OCS Powder Tester PT2C as table version
(Pictures: © OCS Optical Control Systems GmbH)



the products to be produced by the raw material manufacturers, compounders or the plastics, rubbers and recycling industry.

They can be used both as laboratory systems for quality control and assurance and directly in production as online systems for real-time monitoring of polymer (powder) quality. A continuous online measurement is made and an immediate process optimisation can be realised by the operator. The quality of the raw material can also be defined. Faster classifications and approvals of the products can be guaranteed, which ultimately results in better service for the customers. At the Arabplast OCS presented the OCS Powder Tester PT2C, which can be used as a laboratory or online device. With the PT2C powdery materials can be analysed. The system detects impurities that show a colour deviation from the product. A special feature is the optional sorting unit on this system, which simultaneously separates contaminated powder.

■ OCS Optical Control Systems GmbH
www.ocsgmbh.com



THE ZEPPELIN MOMENT

WHEN IT IS THE MIX THAT MAKES OUR SUPERVISOR SMILE.

Zeppelin heating / cooling mixers:
Keep cool – for top products.

The higher the homogenization, the better the quality: Zeppelin heating / cooling mixers generate an intense, three-dimensional mixing effect – the basis for high quality products. And they ensure effective aspiration to perfectly dehumidify the mix for optimal further processing.

All for an excellent product quality.

WE KNOW HOW.





zeppelin-systems.com

PLASTPOL –

The Plastics Industry Keeps Going from Strength to Strength

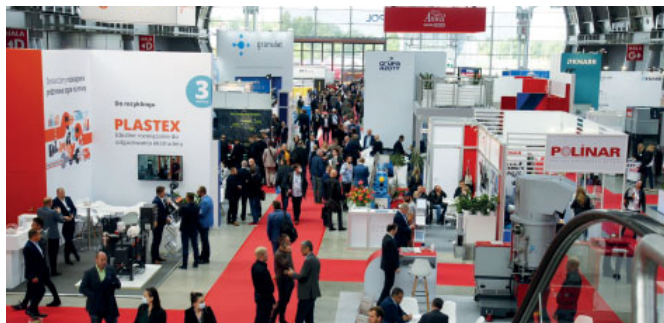

■ Almost 6000 visitors, 300 exhibitors from 22 countries and over 4,000 m2 of exhibition space – this year's PLASTPOL's facts and figures are astounding.

Last year's PLASTPOL was held on a very moderate scale. Yet Targi Kielce was surprised by the positive reception among the exhibitors. Their feedback mentioned that only serious business-focussed visitors came to the expo; they all had specific offers.

Anna Kozera-Szałkowska, Managing Director of the PlasticsEurope Polska Foundation, emphasised, that – the pandemic has not changed leading Europe's and global priorities, including the most important one – preventing climate change. This is to be aided by a zero-emission economy and the introduction of a circular economy in raw materials. The legislative agenda has remained tense over the past several months. The New Circular Economy Action Plan announced at the beginning of last year has additionally strengthened some aspects related to environmental protection. This includes the plastics business.

According to the PlasticsEurope Polska Foundation's report, the plastics industry in Poland has shown resilience in pandemic times. In 2020, employment was maintained, the demand for plastics has increased to an estimated 3.7 million tonnes. The available data on the industry's standing in 2021 indicate a continuation of the dynamic growth which had started in Q4 2020. Despite the problems with the availability of plastics, which reflects the global situation, the rubber and plastics manufacturing sector shows marked increases in sold-production rate compared to the pre-pandemic period. This suggests that 2021 will

be no worse for Poland's plastics industry than last year. The full report is now available on the PlasticsEurope Polska website.

The Waste Management and Recycling Cluster organised a conference open for all, which featured the experts talking on plastics and innovations to close the circulation-loop of raw materials.

Upon the meeting opening, Professor Joanna Kulczycka of AGH University of Technology, the President of the Waste Management and Recycling Cluster, emphasised that entrepreneurs and local governments face many challenges related to waste management and closed-loop economy. At the same time, the President pointed out that there is still no appropriate division of competencies and general-public knowledge of what a circular economy is.

The circular economy is one of the components of the Green Deal. The solutions proposed by the European Commission are WIN-WIN solutions, says the President of the Waste Management and Recycling Cluster.

Therefore, economically viable solutions that would at the same time reduce the so-called resource intensity are in great demand. Consumption of raw materials accounts for over 50% of the impact on climate change; mainly, the change is attributable to coal, oil, cement, chemical raw materials, iron and steel ores, milk and animal husbandry – says Joanna Kulczycka of AGH University. Over 70% of this impact is food consumption, heating and private transport.

The Green Deal in circular economy assumes business models creation which links the waste generator and the recycler in order to close the cycle. A collaborative economic symbiosis is an essential aspect, with plastics as a priority for the European Commission.

The second day of the expo witnessed the Plastech-INFO open technical seminar: "Plastics processing technologies as a driving force for industry development" – the session was crafted around the industry's needs for promotion and knowledge dissemination.

The next Plastpol will be held on May 24-27, 2022.

■ Targi Kielce S.A.
www.targikielce.pl/en/plastpol

New Flake Sorting Test Center in Italy

■ On September 22, 2021, TOMRA Recycling officially opened its new flake sorting Test Center, where the company will develop new applications and solutions in the fields of PO and PET flake sorting while simultaneously expanding its service offering.

Under the theme of "Testing is believing," TOMRA representatives welcomed approximately 100 participants to its exclusive opening event and guided tour of the new flake sorting facility,



located next to its office in Parma, Italy. The inspiring afternoon was filled with informative presentations and demos highlighting the company's long-term plastics strategy, the purpose and goal of the new facility, and the numerous advantages it offers customers.

Fabrizio Radice, VP and Head of Global Sales and Marketing at TOMRA Recycling, started the exclusive event and gave a detailed explanation of the rationale behind investing in a new Test Center. "We have observed an increasing demand for flake sorting tests and a strong market push for high-quality recycled plastics," Radice told the large crowd. "This requires the purest material fractions across all plastics applications, and the respective technologies and solutions need to be identified, developed, and optimized. This will happen in our new facility, while closely collaborating with our customers and partners."

In fact, customer collaboration is at the core of the new facility. Customers from around the world can now ship their plastic flakes to Parma. Together with their respective sales contact, the materials are processed by TOMRA's flake sorting machines. Based on the test analysis and results, TOMRA will recommend the most suitable machine, process and sensor configuration for the customer's defined sorting requirements and goals. Customers are provided with an entire business case tailored to their needs before making an investment.

TOMRA's customers have been benefitting from this concept that has been offered globally (Germany, United States, Japan, Korea, China) for decades. They can now enjoy extended testing capacities, shorter lead times and greater flexibility when it comes to scheduling tests. In addition, its location proves to be particularly convenient. Situated in Parma, at the hearth of one of Europe's most important industrial and production regions, it can be easily reached via the international airports of Milan, Bologna, Verona and Bergamo.

In the second part of his presentation, Radice, detailed why TOMRA is a 'One Stop Shop Solution.' First, TOMRA offers a vast portfolio of sensor-based sorters for various applications with AUTOSORT® and its application-specific complementary products at its core. In the plastics segment, AUTOSORT offers technologies for both presorting and flake sorting that work in unison with each other and allow greater operational and financial benefits. Second, going beyond technology, customers and partners profit from TOMRA's in-depth application knowledge, invaluable consultancy expertise and ongoing service support. The alignment of machines combined with vast expertise and a one-stop service translates into maximum plant performance.

 TOMRA Sorting GmbH
www.tomra.com/recycling



New factory New beginning

lesunscrew.com

Production Plant to Poland

■ Grupa Azoty's plant in Tarnow, Poland, has been put into operation at the end of 2019. The mechanical engineering company FEDDEM had provided the planning for the entire technology and the production building at the time. Now production is already being expanded.

The new FEDDEM extruder FED 72 MTS is scheduled to go into operation in early 2022. With this additional plant, which, just like the plant built in 2019, complies with the ICX® technology developed by FEDDEM, the compounder will thus increase its production capacity to almost 40,000 tonnes/year.

"The ICX® technology enables an identical production concept at different locations and creates uniform production conditions, equivalent products and a minimum of spare parts stock," explains Dieter Groß, Managing Director of FEDDEM GmbH & Co. KG. According to the machine manufacturer, this makes it possible not only to reduce costs, but also to increase the quality/price ratio. The flexible systems used here adapt quickly and easily to changes in customer needs. Sustainability and energy efficiency are equally important factors.

"The increasing demand for our plastic compounds and the positive business development with our cooperation partner AKRO-PLASTIC quickly led to the utilisation of our current compounding capacity. We are therefore pleased to be able to cover the developing volume growth with a capacity



A FEDDEM extruder of the FED 72 MTS model series will be installed at Grupa Azoty's plant in Tarnow in early 2022

expansion," says Dariusz Cholewa, Managing Director of Grupa Azoty Compounding.

► **FEDDEM GmbH & Co. KG**
www.feddem.com

Forces on Renewable Raw Materials for Plastics Production Joined

■ Specialty chemicals company LANXESS and energy company bp are entering into a strategic partnership for the use of sustainable raw materials in high-tech plastics production. bp will supply sustainably produced cyclohexane to the LANXESS' production site in Antwerp, Belgium, starting in the fourth quarter of 2021. The sustainable origin of the raw materials is certified according to ISCC Plus rules ("International Sustainability and Carbon Certification"). With this partnership, both companies, which already have a long-standing business relationship, want to significantly advance the production of sustainable plastics.

"The chemical industry plays an important role in the expansion of the circular economy and efficient sustainable management. To meet the global challenges of climate change, creative approaches to solutions and collaboration are needed in service of our customers. We are pleased to accompany LANXESS as a strong partner with

a broad portfolio of raw materials from renewable sources," says Wolfgang Stückle, Vice President Midstream Refining and Specialities Solutions Europe and Africa of bp. bp uses bio-based and bio-circular feedstocks for the production of "green" cyclohexane. These can be, for example, rapeseed oil or biomass.

"High-performance plastics are the solution for many sustainable products, for example in various e-mobility applications. It is now important to also make the production of this valuable material sustainable. In this context, the use of bio-based raw materials, along with modern recycling processes, is a key lever. We are delighted to have bp as a strategic partner at our side," says Marcel Beermann, Head of Global Procurement and Logistics at LANXESS.

► **LANXESS AG**
www.lanxess.com

Award – Recycling Machinery Innovation of the Year

■ EREMA is winner at this year's Plastics Recycling Awards Europe. At the award ceremony as part of the Plastics Recycling Show Europe at 5th November in Amsterdam, EREMA was awarded for its recycling system INTAREMA® TVEplus® ReGrind-Pro® + ReFreshener in the category Recycling Machinery Innovation of the Year. Thanks to the combination of its recycling machine with the ReFreshener technology that reduces odour downstream of the extrusion process, EREMA has enabled the PCR-HDPE produced with it to be used in proportions of up to 100 percent for the production of packaging for direct contact with food and beverages, as confirmed by the U.S. Food and Drug Administration (FDA).

The judges recognised this innovation as a step change in eliminating unwanted odour from waste plastics, allowing recyclate to replace virgin plastics in high end applications. This type of innovation is essential for meeting EU targets for recycled content of food contact plastics.

The market also confirms awarding this technology. By the end of 2021, EREMA customers will produce 450,000 tonnes of high-quality, odor-optimized regranulate per year, with it.

This recycling process is seen as a key technology to recycle HDPE food packaging into recyclate to be reused in high quality packaging for cosmetic products or for food. "We are very pleased about this award, because it is a visible proof of the companies innovation capacity and the outstanding quality of the awarded recycling system", says Michael Heitzinger, Managing Director EREMA GmbH.

The INTAREMA® TVEplus® ReGrind-Pro® + ReFreshener recycling process was also certified by the FDA in August 2019 as suit-

able for the production of milk and juice bottles, as well as meat trays, disposable tableware and cutlery, provided the input material comes from milk and juice bottles. In November 2020, the FDA confirmed an additional input stream and more application uses for the recyclate treated using this process. In addition to all HDPE beverage containers, HDPE closures of HDPE, PP and PET beverage bottles can also be processed. Material containing up to 100 percent recyclate can be used in the production of containers for direct contact with food of all kinds. An important milestone on the way to Circular Economy.

The EREMA Team with Michael Heitzinger, Managing Director EREMA GmbH (far left in the picture), is very proudly presents the Award for the Recycling Machinery Innovation of the Year



■ EREMA Engineering Recycling Maschinen und Anlagen GmbH
www.erema.com

Market Study: Polyvinyl Chloride

■ More chlorine, less crude oil: large quantities of by-products from the chemical industry are used to manufacture polyvinyl chloride (PVC). PVC is therefore one of the most cost-effective plastics - and, along with polypropylene and polyethylene, also the most widely used. Ceresana has analyzed the growing market for PVC for the sixth time: The analysts expect the demand for this both robust and versatile material to increase to around 57 million tonnes worldwide by 2030.

The construction industry is expected to remain the most important market for PVC in the future, accounting for around two-thirds of the global demand. Flooring also accounts for a significant share of global PVC demand. The second largest market is the packaging industry, which uses PVC for flexible and rigid packaging, with a share of nearly 16.5%.

In 2020, pipes and pipelines were the most important PVC products with a share of over 37%. They were followed by profiles (20.3%) and films and sheets (17.3%).

Rigid PVC and flexible PVC in one study: Chapter 1 provides a presentation and analysis of the global market for PVC - includ-

ing forecasts up to 2030: demand and revenue are explained for each region of the world. Additionally, the demand is analyzed both by product and by application area. The various PVC products are examined in detail.

Further, the study examines the application areas of PVC: Flexible packaging; Rigid packaging; Construction; Vehicles; Electronics: Industry; Other sectors.

In Chapter 2, 46 countries are examined individually. Country-specific demand, revenue, production, capacities and trading, demand per PVC product and application, as well as demand per PVC type (rigid and flexible) are depicted.

Chapter 3 provides useful company profiles of the most significant manufacturers of PVC, clearly arranged by contact details, revenue, profit, product range, production facilities, capacities and brief profile. Detailed profiles are provided by 81 manufacturers.

■ Ceresana
www.ceresana.com/en/market-studies/plastics/polyvinyl-chloride/

Acquisition



ALPLA is acquiring BTB PET-Recycling based in Bad Salzuflen, Germany. The company turns used PET bottles into recycled material (Copyright: ALPLA)

■ The ALPLA Group is acquiring BTB PET-Recycling based in Bad Salzuflen, Germany. The company turns PET bottles into recycled material which is then predominantly used for the production of new beverage bottles. Its bottle-to-bottle packaging cycle is a closed loop.

BTB stands for 'bottle-to-bottle', in other words a closed packaging loop that turns bottles collected in the region into new bottles. First, BTB pre-sorts, shreds and washes the input material, then sorts it again. It is then melted down in an extrusion process and turned into pellet form, resulting in valuable food-grade rPET. The processing volume is around 20,000 tonnes of PET bottles each year. The company has approximately 35 employees, all of whom will be kept on by ALPLA.

Just recently, ALPLA and its partners announced the founding of the joint venture PET Recycling Team Targu Mures for the recycling of post-consumer PET bottles in Romania. The target is annual production of 15,000 tonnes of food-grade rPET to strengthen the local materials cycle in Central and South-Eastern Europe. In the UK, ALPLA has been cooperating with the British waste management company Biffa since this year and sources food-grade rPET pellets from the Biffa recycling plant in Seaham. With this collaboration, ALPLA is increasing the proportion of British recyclate used to manufacture packaging in the UK.

In early 2021, the ALPLA Group announced that it would invest an average of 50 million euros a year until 2025 in the ongoing expansion of its recycling activities. In particular, it plans to globalise its activities in the area of high-quality recyclates

in order to close the materials cycle in as many regions as possible. In all, the annual capacity of the ALPLA recycling companies, joint ventures and partnerships amounts to approximately 130,000 tonnes of PET and 60,000 tonnes of PE.

In addition, the ALPLA Group is taking over Plasticsax S.L. The Spanish company produces plastic bottles for the cosmetics, home and personal care segments. The takeover will enable an increased use of recycled material in production operations and a strengthening of the circular economy in the region.

With the purchase of the Spanish bottle manufacturer Plasticsax S.L. based in the province of Alicante, ALPLA is consolidating its market position in eastern Spain and expanding its production capacities mainly for packaging solutions made from the plastic HDPE (high-density polyethylene). A smaller product area also includes bottles made of PET (polyethylene terephthalate). EBM (extrusion blow moulding) and SBM (stretch blow moulding) are used as production technologies. The company has 58 employees who will be taken over by ALPLA.

ALPLA plans to increasingly manufacture products with a high proportion of post-consumer recycling material (PCR) in the new plant.

In autumn 2019, ALPLA bought two HDPE recycling companies near Barcelona and Valladolid. They ensure the supply of the production facilities in the region with PCR and contribute to strengthening the local bottle-to-bottle circular economy cycle.

ALPLA is taking over Spanish bottle manufacturer Plasticsax based near Alicante (Copyright: ALPLA)



ALPLA Group
www.alpla.com

Upgrading Plastic Waste into Valuable Products

■ The "Innovation in Vacuum Busch Award 2020" has been presented to the Norwegian company Quantafuel ASA. By employing Busch's DOLPHIN liquid ring vacuum pumps, Quantafuel has developed technology that is contributing to solving the global waste problem by upgrading plastic waste into valuable products.

Busch Vacuum Solutions presents its innovation award every year. This honor is awarded to individuals or businesses who come up with particularly innovative ways to apply vacuum technology and benefit the human world and the environment as a result. The award was first presented back in 2013 to mark Busch's 50th anniversary.

Quantafuel develops technology that is contributing to solving the global waste problem. In collaboration with dedicated partners, they have achieved the combined goals of recycling low-quality plastic and sustainable waste management. And Busch Vacuum Solutions is one of these partners that delivers the vacuum technology for the pyrolysis process to give plastic waste a second life. By converting almost all kinds of plastic waste into more environmentally friendly fuel and chemicals, Quantafuel is making a significant contribution to lowering pollution and emissions.

The two companies are linked by a close partnership. Busch supports Quantafuel during the development of the innovative pyrolysis process where they melt all sorts of used recirculated plastic waste and generate mineral oil out of the pyrolysis gas. The mineral oil itself arises in the melting process. DOLPHIN liquid ring vacuum pumps by Busch are used for degassing during the pyrolysis process. The gas is then compressed for further downstream process with the help of vacuum technology.

This innovative process makes the recycling of plastic waste much more environmentally friendly. Quantafuel's



Presentation of the "Innovation in Vacuum Busch Award 2020"; from left to right: Dr Karl Busch, Ayhan Busch, Oyvind Hansen Billing (General Manager Busch Vakuumteknikk AS), Hans-Christian Felde (Procurement Director Quantafuel ASA), Ayla Busch, Kaya Busch

solution places a value on plastic waste by treating used plastic as a valuable resource and transforming it into new products. And therefore, Busch presented Quantafuel with the "Innovation in Vacuum Busch Award 2020".

Busch Vacuum Solutions
www.buschvacuum.com

Cooperation

■ As part of its growth strategy for its biopolymers business, BASF will cooperate with WPO Polymers to further advance on the fast developing Spanish and Portuguese markets: The plastics solutions provider will act as distributor of BASF's ecovio® film product range for certified compostable shopping bags, organic waste bags as well as fruit and vegetable bags in Spain and Portugal. Building on their respective strengths, BASF and its new partner will be better positioned to accelerate business on this important market and to support food companies and retailers to comply with the Spanish Royal decree 293/2018 on the reduction of plastic bags including the mandatory usage of compostable bags (<50 µm thickness) certified according to EN 13432.

„We have chosen WPO Polymers as partner because of its recognized technical expertise in the field of extrusion and its in-depth knowledge of recycling and plastics materials, which complements BASF's customer-focused strategy for ecovio® in the Spanish market," says Mia Pettersson, head of BASF's global business unit Specialty Polymers. „With this new partnership,

we want to further improve services for our processors through greater proximity, to meet our customers' needs more effectively and increase our delivery flexibility. The cooperation will also allow us to support the separate collection of organic waste, as high-quality compost is important for climate change mitigation." Since 2018 Spanish legislation has step by step tightened the consumption of bags made of conventional plastics, which in this year culminates in the obligation for retailers and bag producers to offer only light and very lightweight certified compostable bags to consumers. Thus, the Spanish market for biopolymers is expected to become one of the largest in Europe.

„Our expertise is backed by more than 40 years of experience in the plastics industry. With the inclusion of BASF's innovative biopolymer ecovio® into our portfolio, we will both expand our established business and push the adoption of organic recycling in the Iberian peninsula," says Manuel Olaegu, CEO and Founder of WPO Polymers. „We give tailored material advice and technical support to each customer to ensure the optimal use of the right material for the respective process and certified compostable application – these are key success factors in the Spanish and Portuguese bioplastics markets."

The BASF biopolymer ecovio® is certified compostable in accordance with e.g. DIN EN 13432. It is a blend of BASF's PBAT ecoflex® and renewable raw materials, which means that ecovio® is also partly bio-based. Typical applications for ecovio® are organic waste bags, cling film, fruit and vegetable bags, as well as agricultural mulch films and food packaging applications.

BASF
www.ecovio.basf.com, www.biopolymers.basf.com

WPO Polymers
wpopolymers.com



Presence in Asia Expanded

■ The Biesterfeld Group, Hamburg, Germany, has established a joint venture by acquiring a majority stake in Singapore-based GME Chemicals. The closing was now completed. A complete takeover of the remaining shares will take place in five years, according to the contract. By acquiring a stake in GME Chemicals, one of the leading distributors of specialty chemicals and polymers in South-East Asia, Biesterfeld is continuing its geographic expansion and growth strategy and laying the foundation for a targeted and long-term expansion of its market position in one of the world's fastest-growing regions in its core business.

GME Chemicals is active in the markets for performance and industrial chemicals, food, pharmaceuticals, elastomers and specialty polymers, and also in developing sustainable solutions for their customers. The company, which was established in 1999 in Singapore, has grown successfully and is represented by operating subsidiaries in Malaysia, Indonesia, Vietnam, Thailand and China, and has 60 employees.

Dirk Biesterfeld, Chairman of the Supervisory Board of Biesterfeld AG, explains: "Asia is a significant growth market and of strategic importance to us. Here, too, we want to significantly increase our market presence together with our suppliers. As a family-owned company, reliability, a long-term commitment,



From left to right:
SH Liow, Executive Director GME Chemicals,
Philip Chew, Managing Director GME Chemicals,
Pernod Sim, Executive Director GME Chemicals



From left to right: Carsten Harms, Member of the Executive Board Biesterfeld AG and Managing Director Biesterfeld Plastic and Biesterfeld Performance Rubber, Thomas Arnold, CEO Biesterfeld AG, Peter Wilkes, Managing Director Biesterfeld Spezialchemie, Kai Froböse, CFO Biesterfeld AG

and the joint cooperation of all employees are particularly important to us. The GME portfolio is an excellent addition to the Biesterfeld Group and we are gaining highly qualified employees. I look forward to the cooperation and a successful future together."

Philip Chew, Managing Director and shareholder of GME Chemicals, emphasizes, "In Biesterfeld, we have not only found a majority shareholder and, in the future, a new owner, but a true partner. We share the same business view and the same values. As shareholders, we will therefore remain in the company with our management team and our employees. I am sure that with our know-how, we can jointly and significantly expand the solution portfolio for customers in Asia and accelerate the growth of our suppliers in our markets. I look forward to our continued journey as part of the Biesterfeld Group."

■ **Biesterfeld Group**
www.biesterfeld.com

GME Chemicals
www.gme-chemicals.com

Green Packaging Star Award

■ Mondi has won three awards for sustainable packaging at the Austrian Green Packaging Star Awards. The annual Green Packaging Star Awards recognise environmentally-friendly packaging and recycling solutions, as well as packaging-related improvements in operational processes in production, logistics, and distribution. The award is presented by Kompack magazine and the Austrian Research Institute for Chemistry and Technology.

The judges of these awards recognised the high standard of the following three Mondi products:

EcoVantage paper for Tesco shopping bags, Functional Barrier Paper substituting plastic packaging, and WalletPack Re-



cyclable for well-known German deli meats. Working with Bell Germany, Mondi created packaging for the meat producer's 'Abraham' range of sliced deli meats. WalletPack Recyclable, a mono-material solution that helps prevent food waste and has been verified by the German institute cyclos-HTP as 93% recyclable. The folded approach keeps the deli meats fresh and easy to access and requires 37% less material to be produced. Launched in early 2021, it is set to save 35 tonnes of plastic waste per year for Bell Germany.

Peter Orisich, CEO Flexible Packaging & Engineered Materials, Mondi, says: "We are committed to taking action on climate and creating circular driven solutions. With our action plan, MAP2030, we have set out our ambitious sustainability commitments and targets for the next ten years. We are delighted that these product have been recognised by the Kompack Green Packaging Star awards for their sustainability credentials."

■ **Mondi**
www.mondigroup.com

In-House Rheology Lab launched

■ Guill Tool, manufacturers of extrusion tooling for the global market, has opened an in-house rheology laboratory, making it the only extrusion tooling manufacturer in the industry with such a capability. Seeking to obtain better results and minimize the time it takes between testing and production, Guill built its own rheology lab in their facility in West Warwick, Rhode Island, USA. The lab features several key machines that ensure optimum results, when testing materials, especially new compounds to be extruded. The testing equipment includes a Hybrid Rotational Rheometer, a Differential Scanning Calorimeter, and a Thermal Conductivity Meter.

Third-party testing facilities are typically not experienced in extrusion processes. Guill, however, can not only gather data the same way third-party testers can, but can also interpret that data as it applies specifically to extrusion. Likewise, third-parties simply supply data, not recommendations. Guill is now equipped to both test its customer's materials and work with them to create

TA Instruments DTC-300 Thermal Conductivity Meter



New Guill Rheology Lab at company headquarters in West Warwick, Rhode Island



TA Instruments Discovery HR-2 Hybrid Rotational Rheometer



TA Instruments DSC-25 Differential Scanning Calorimeter



extrusion tooling that will give them a competitive edge. Accurate simulation and interpretation by extrusion experts greatly reduces the number of physical reworks needed, as the tooling has a greater chance of producing a good product at the outset. In-house testing also speeds up the turnaround on test results, reducing delays during the tool design process and offering better control over the processes and test parameters.

The new Guill rheology lab processes standard materials, custom formulae and it is equipped to mix materials. These materials include plastics, thermoplastic elastomers, all types of rubber and silicone. Information from the lab is transmitted directly to the Guill engineering department via computer link for review by the design team.

The lab will be offered for use by extruders and chemical formulators, among others in the industry. Please contact Guill for full details.

■ Guill Tool & Engineering
www.guill.com

Low-Leakage Couplers

■ Absolute cleanliness is required in production under cleanroom conditions such as in the food or pharmaceutical industries. Of course perfect cleanliness is also essential for temperature regulation. The new low-leakage couplers from Meusbürger provide the optimal foundation for this.

The new E 25... low-leakage couplers have a flat-face valve on both sides. This ensures that no empty space is created when decoupling so no media can escape, which allows for clean production and user safety. The long pilot guarantees complete sealing and durability, and thanks to the O-ring seal on the fitting, the coupler can be screwed in clean and quick – without any thread sealant at all.

The low-leakage couplers are available with hose or quick-fit nozzle and with thread in straight and 90° angled versions, available in the common nominal widths DN6 and DN9. Couplers with convenient one-hand operation engage automatically. The minimal pressure drop is due to the optimised flow geometry.



Meusbürger's low-leakage couplers provide the optimal foundation for clean temperature regulation (Image: Meusbürger)

The standard version is already equipped with special sealing for water up to 150° C and oil up to 200° C. The threaded version is also available in a high-temperature version with a turquoise ring for identification. The special FKM seals installed in them are specially designed for hot water up to 180° C and tempering oil up to 220° C and are extremely durable. This guarantees optimal process safety in the production.

■ Meusbürger Georg GmbH & Co KG
www.meusbuerger.com

PET Solution for 100% PCR Use in Direct Food Contact Exhibited

■ The Reifenhäuser Group exhibited its latest innovations for flat and blown film production at ArabPlast 2021 in Dubai at November 15 to 18.

The Reifenhäuser Cast Sheet Coating business unit, which specializes in flat films, presented its pioneering solution for producing sustainable PET sheet from up to 100% PET bottle scrap (PCR) for direct food contact. Customers process post consumer recyclate (PCR) on Reifenhäuser MIREX PET sheet lines, not only as an intermediate layer between two outer layers of virgin material, as widely used in the food packaging sector. If required, the film can be made from PCR PET only. The end product meets the highest hygiene standards and can be used safely - even in direct contact with food.

Another highlight of the MIREX PET sheet lines is PCR flake processing without pre-drying. This is achieved on the tried-and-tested co-rotating twin-screw extruder "REItruder". Processors therefore benefit from lower energy costs, as it eliminates the crystallization and drying steps in the process. In addition, the line features a special backflush filtration system for extremely high melt quality and process consistency. The result is perfect optical and mechanical film properties.

The Reifenhäuser Blown Film business unit specializing in blown film also exhibited with solutions that produce sustainable end products. The technology answer here is EVO Ultra Stretch – Reifenhäuser's advanced stretching unit for fully recyclable blown film. It allows customers to produce mono-material com-



Sustainable solution for flexible packagings: Reifenhäuser All-PE Pouch

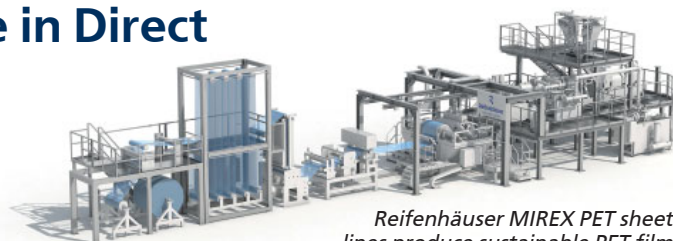

Reifenhäuser MIREX PET sheet lines produce sustainable PET film from up to 100% PET bottle scrap (PCR) for direct food contact (in compliance with FDA-LNO) (Photos: Reifenhäuser)



Reifenhäuser EVO Ultra Stretch: The position of the stretching unit directly in the haul-off of the blown film line is patented and is a unique selling point on the market

posites (all-PE film) for flexible packaging and replace the otherwise usual PET layer with stretched PE. With up to 10 times the stretch rate, the Ultra Stretch stretching unit gives PE film completely new mechanical properties. This is a simple replacement for PET and there is no need to adapt other processing steps. The unique and patented position of the stretching unit directly in the haul-off of the blown film line makes the process particularly stable and efficient. The Ultra Stretch process is unique on the market and offers decisive advantages over the otherwise usual process of stretching the film between the take-off and the winder.

Visitors to the Reifenhäuser booth in Dubai had the chance to experience the impressive Ultra Stretch technology, as well as the latest blown and flat film lines, on a large screen as part of a virtual 360° tour through the Reifenhäuser Film Technology Center.

■ Reifenhäuser Group
www.reifenhäuser.com

New 500 Series Rubber/Silicone Extrusion Crosshead

■ Guill Tool introduces the NEW 500 Series crosshead with MAGS gum space adjustment. The 500 Series is designed specifically for the flow characteristics and unique processing challenges of elastomeric compounds. One of the key features engineered by Guill on this new crosshead design is the mechanically assisted gum space (MAGS) adjustment system. This new method of gum space adjustment allows the operator to make an effortless adjustment from a single point using a common socket wrench. No more need to struggle with multiple nuts and bolts

in order to adjust gum space, which leads to faster adjustments. The visual indicator on the core tube allows the operator to see how far the gum space has been moved, making those adjustments much more accurate and repeatable.

The hardware-free and patented cam lock design of the NEW 500 Series from Guill means no time is wasted unbolting and re-securing fasteners for disassembly and re-assembly. Only half of a rotation of the cam nut is required to loosen and automatically extract the deflector from the head body, which is another

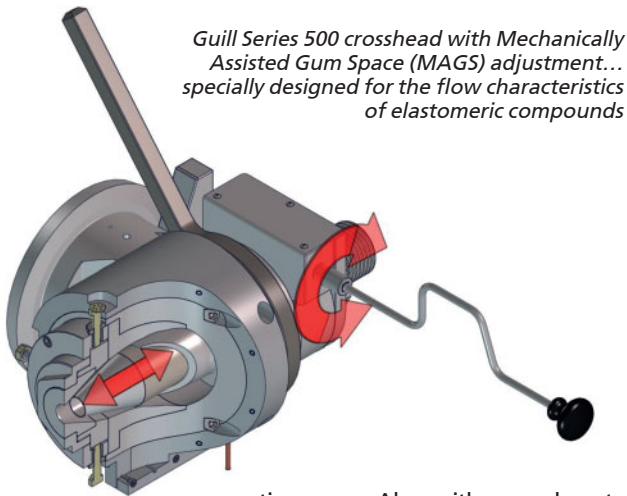

Guill Series 500 crosshead with Mechanically Assisted Gum Space (MAGS) adjustment... specially designed for the flow characteristics of elastomeric compounds

time saver. Also, with no undercuts on the deflector, there are no material hang-ups when extracting the deflector, allowing for faster and easier cleaning and changeover. The NEW 500 Series also features the latest Center-Stage concentricity adjustment system that significantly reduces pressure on the tooling, allowing easier and more precise concentricity adjustments without loosening the face bolts. Easy-Out inserts for the adjusting bolts also allow simple replacement of locked or damaged adjusting bolts, which further saves on repair and downtime.

Another innovative feature of this new rubber/silicone crosshead is a cast aluminum liquid-fed cooling sleeve that allows the user to switch out the cooling jacket in the event of a line obstruction, again reducing downtime compared to traditional integrated cooling systems.

The NEW 500 Series crosshead with MAGS gum space adjustment is a drop-in replacement on most existing NRM lines, however this crosshead design can also be adapted to fit any extruder design or line layout.

The addition of a newly designed flow inlet channel reduces the shear and heat that is generated as the materials are being processed. This leads to lower head pressures allowing the material to move through the head in a much more balanced and even flow.

All crossheads supplied by Guill are furnished with a tool kit for assembly and disassembly as well as a detailed operator's instruction manual. The engineering team at Guill will gladly assist users in the implementation and operation of the NEW 500 series crosshead.

For a video of the NEW Guill 500 Series crosshead with MAGS gum space adjustment, please go to: <https://youtu.be/jeNovmMtcBs>

Guill Tool & Engineering Co., Inc.
www.guill.com

European Bioeconomy Robust

■ The bio-based industries continue their ascent marking a total contribution of 780 billion EUR, an increase of 30 billion EUR (+ 4%) compared to 2017. This represents a more than 20% increase compared to 2008 which is the earliest data taken into account in this series of reports by nova-Institute. The first report of the series was first commissioned by the Bio-based Industries Consortium (BIC) in 2017. Figures for the bio-based chemical industry (including plastics) alone reveal a turnover of around 54 billion EUR with the bio-based share relatively stable at around 15%, up from 7.5% in 2008.

The analysis of the 2018 Eurostat data shows that the turnover of the total bioeconomy*, including food and beverages and the primary sectors of agriculture and forestry, amounts to just over 2.4 trillion EUR in the EU-27 and the United Kingdom, an increase of around 25%. The food and beverage sector accounts for about half of the turnover, the bio-based industries, such as chemicals and plastics, pharmaceuticals, paper and paper products, forest-based industries, textiles, biofuels and bioenergy account for roughly 30%, while almost another 20% are generated by the primary sectors of agriculture and forestry.

In contrast to the rising turnover figures, employment in the European bioeconomy has declined slightly from 18.5 million people in 2017 to a total of 18.4 million people in 2018, largely due to efficiency increases in production. The primary biomass production, mainly agriculture, provides a majority of the entire employment (54%) but a comparatively low turnover (20%).

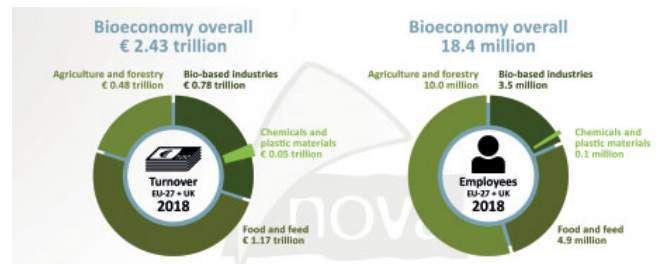

The data also demonstrates clear differences between groups of Member States. For example, the Central and Eastern European countries of Poland, Romania and Bulgaria are more represented in the lower value-added sectors of the bio-based economy, which create many jobs. This indicates a strong agricultural sector that tends to be labour-intensive compared to the high value-added sectors. In comparison, Western and Northern European countries generate much higher turnover relative to employment, indicating a larger share of refining and value-added industries. The countries with the highest turnover-to-employment ratios are Finland, Belgium and Sweden.

*The primary sectors (agriculture, forestry, and fisheries) and the food, beverage, tobacco and paper and paper products can be considered fully bio-based and are thus fully accounted for in the bioeconomy. For other manufacturing sectors such as chemicals, pharmaceuticals and textiles, the bio-based shares were estimated and included in the report's assessment.

nova-Institut GmbH
www.nova-institute.eu
Bio-based Industries Consortium (BIC)
www.biconsortium.eu

Medical-Grade TPE Film for Wound Healing Applications Developed

■ United Soft Plastics (USP) has developed a custom extruded TPE film which delivers a high level of patient support and treatment-friendly wound healing. The developmental grade makes an effective contribution to increased protection for patients and medical nursing staff.

Patients who have been treated with wound dressings for injuries to their arms and legs must receive regular medical care. It is essential to keep the area of the wound dressing clean and dry before any follow-up treatment or daily aftercare and at the same time to protect it from dangerous bacterial ingress.

Previously, this has been done by covering the wound dressing with a medically protective film or protective bag (polybag), which is then affixed to the skin with an adhesive tape and sealed. However, the removal of the protective film by tearing off the tape from the skin usually causes unpleasant pain in connection with unwanted micro-injuries to the topmost skin layer.

The USP custom medical grade TPE, which was developed in conjunction with a Danish start-up under the brand name Impervious, relieves patients of undue irritation and pain. The TPE film is a latex-free alternative and does not have to be torn off because it is permanently welded to the polybag as a stretchable, flexible, and conical sealing strip. As a result, the use of adhesive tape can be completely eliminated. The TPE film product represents a significant relief in everyday treatment for patients and medical nursing staff, according to Michael Bodmann, USP General Manager-Europe.

“When we were approached by one of our European customers about this idea, we were initially not sure whether



we would actually be able to develop a medical TPE grade that combines a multitude of partly contrary performance properties along with the need to meet strict customer and medical regulatory requirements,” said Bodmann.

The TPE grade exhibits a low Shore A hardness (25-35), high tear strength in connection with demanding transverse and longitudinal strain loads, and the indispensable requirement of a very thin wall thickness (0.2-0.4 mm). The company also addressed manufacturing issues so the medical-grade TPE could be produced in a cost-effective manner, said Bodmann.

The year-long joint development project is in a pre-commercialization phase and undergoing clinical trials. After initial commercialization in Europe, the new TPE film will be made available globally.

■ **United Soft Plastics (USP)**
www.unitedsoftplastics.com

Impervious
www.impervious.dk

Sales Partnership for Switzerland

■ The GRAFE Group, Blankenhain, has found a new sales representative for Switzerland in Polynova Group AG, Risch-Rotkreuz (Switzerland). The partnership has been officially launched at Fakuma 2021. “Our new Swiss agency specialises in the distribution and production of high-quality technical plastic granulates and has been active on the market for more than 20 years. The company has a large customer base and the necessary technical expertise to advance our goals in this important market. This includes raising our profile, educating people about our product range and ultimately gain-

ing market share,” says Stefanie Theuerkauf, Sales Manager for the D-A-CH region.

Polynova employs five sales staff and three in logistics, all of whom have a technical background. The company’s own warehouse in Rothenburg also ensures the availability of the plastics.

■ **GRAFE Advanced Polymers GmbH**
www.grafe.com

Portfolio of High-Performance Light Stabilizers Expanded

■ UniteChem Group, the world's leading supplier of light stabilizers for plastics in a broad range of high-end industrial applications, has recently started full-scale production of advanced high-performance light stabilizers UniteChem LS2020 and LS119 in its newly commissioned production facilities.

"UniteChem Group began producing industry-standard light stabilizers such as UniteChem LS944 in 1997 and has been continuously expanding its polymer additives portfolio ever since", says Junyi Lin, CEO of UniteChem Group. "Today, we are proud to be among the world's largest-capacity suppliers of light stabilizers and other plastic additives, offering over 40'000 tons of finished products. Our full backward integration with a production capacity of over 80'000 tons of intermediates provides extensive production flexibility, high reliability, and maximum quality control. Current production, located in two state-of-the-art production facilities in

(Photo: UniteChem)



Jiangsu province, is now in process of being complimented with two new major production facilities in Jiangsu and Sichuan provinces, with completion in 2022/23."

UniteChem LS2020 is a modern HALS (hindered amine light stabilizer) offering excellent anti-aging properties in applications such as cross-linked polyethylene, olefin copolymers and other polymer materials. UniteChem LS119 is especially suited for use in polyethylene greenhouse film applications, polypropylene fibers, TPO automotive parts as well as other polymers such as EVA, EPDM, PA, PET and PMMA. With these product additions, UniteChem Group further enhances its commitment to offer customers the most up-to-date and value-added product portfolio.

Junyi Lin added: "The production of UniteChem LS2020 and LS119 is currently being methodically ramped up, with target capacities of 1'000 tons and 2'000 tons annually to meet global demand."

As part of its commitment to invest in future solutions for its customers, UniteChem Group regularly allocates five percent of its total revenue to R&D, operating five independent laboratories – including its recently opened modern Shanghai R&D Center. Current efforts focus on expanding the group's portfolio with high-demand UV Absorbers, NOR-HALS light stabilizers as well as other key polymer additives.

■ UniteChem Group
www.unitechem.eu

Activities in Mexico Expanded

■ The machine building company specialized in innovative, sustainable blow molding solutions is moving into a new and improved office space in Mexico City. The new location will serve as a hub for the company's sales and service activities in the growing markets in Mexico and other Latin American countries. Erick Yllescas, as new Sales Director Mexico, will be in charge of managing the activities. He is supported by a team of ten Kautex employees focusing on field and remote support in English- and Spanish language.

Erick Yllescas has been working for two decades in leading positions for various international companies in the Industrial Automotive and Plastics Sector in Mexico and Latin America. Being a business advisor for several years he knows how to develop markets and has a strong customer focus.

Mexico is considered the most advanced country for processing HDPE thermoplastics for the packaging industry in Latin America. Mexican companies have a very high technical standard and also reach the level of European countries in the area of recovery and recycling. With a share of 58 percent, Mexico is also the largest importing country for machines and molds in Latin America. According to ANIPAC, the Association Nacional de Industrias del

Plástico A.C., extrusion blow molding has a share of 27 percent of the total plastic production in Mexico.

"Mexico is an important growth market for us with an impact on many countries in Latin America. We see a great demand here, especially for our innovative Skyreef machine platform for consumer and industrial packaging. The platform enables flexible and demand-oriented adaptation of the line to the specific market conditions and product requirements of our customers," explains CEO Thomas Hartkämper.

Kautex Maschinenbau is one of the leading international manufacturers of extrusion blow molding machines for the production of hollow containers for the consumer and industrial packaging industry, automotive and special applications sectors. According to its mission statement "BeOne – with customers and partners", the company develops smart and sustainable production solutions for value-added articles. In addition to its three main locations in Bonn (Germany), Shunde (China) and New Jersey (USA), Kautex Maschinenbau is represented by subsidiaries in numerous countries around the world. The Mexican office was now relocated to the German Centre Mexico in the southwest of the Mexican metropolis.

■ Kautex Maschinenbau GmbH
www.kautex-group.com

Range of Food Contact TPEs Extended



Today's buyers are making informed decisions about the safety and health advantages of the goods and materials they buy (Image: © 2021 KRAIBURG TPE)

■ Consumers are increasingly focusing on the safety and health benefits of goods and materials when making purchasing decisions. This means manufacturers have to ensure compliance with national and international food safety regulations in order to attract more customers. To meet this demand on a global level, KRAIBURG TPE now extends its offering of Food Contact TPEs with a new THERMOLAST® K series.

A shift in consumer behavior can be observed: Today's buyers are increasingly taking responsibility for their own well-being by making informed decisions about the safety and health advantages of the goods and materials they buy. This change does not happen by chance. Toxic chemicals leaching from compounds or materials are major concerns in the manufacturing and consumer goods industry. That is why food contact safe materials such as thermoplastic elastomers (TPEs) are gaining popularity. The change has far-reaching

consequences for manufacturers. As a result, they are driven to ensure compliance with national and international food safety regulations to attract more customers. Enter KRAIBURG TPE, a global TPE manufacturer of thermoplastic elastomer products and custom-engineered TPE solutions for diverse consumer product applications, offering food contact safe and safety regulation compliant TPEs.

KRAIBURG TPE's latest addition to its Food Contact TPE portfolio is a material solution for everyday consumer applications that require stringent conformity with a wide range of standards, including (EU) No. 10/2011, GB 4806 and (FDA) CFR21 as well as DIN EN 71-3 for toys. It also features properties such as adhesion to PP, optimized flow, and hardness range from 30 to 90 Shore A. The materials are easily processable by processes such as injection molding, extrusion and 3D printing. Furthermore, the compounds in the Food Contact TPE series are free from animal ingredients, heavy metals, phthalates, bisphenol A, and latex, accommodating to the production of sustainable goods.

"Ensuring consumer safety is crucial for today's manufacturers of consumer products," states Lee Jia Yin, Product Developer at KRAIBURG TPE. "KRAIBURG TPE's new Food Contact TPE series satisfies food safety material requirements and complies with REACH, SVHC and RoHS. The good haptic and soft-touch properties of the new series of compounds are ideal for applications such as household goods, packaging for food and consumer care products, razors, toothbrushes, toys and other products."

The compounds are available in natural and translucent colors with the option of in-house pre-coloring, allowing the flexibility of a variety of product solutions.

■ KRAIBURG TPE
www.kraiburg-tpe.com

Flame Protection Activities in Europe Strengthened

■ International chemical distributor Nordmann wants to strengthen the European alignment of its flame protection business even further in future and thus expand its leading position in this area.

For decades, Nordmann has had a wide portfolio and extensive expertise in the area of flame retardants in plastics, elastomers, coatings, adhesives and other application fields. A key pillar here is the halogen-free flame retardants, distributed under the company's own NORD-MIN® brand. These include expandable graphites, ammonium-polyphates as well as melamine cyanurates and flame retardant masterbatches.

Additionally, there is the long-term, successful collaboration with internationally leading manufacturers of flame retar-

dants and synergists such as Rio Tinto and Nyacol from the USA, Tolsa from Spain and Fushimi from Japan, whose products Nordmann distributes in Europe.

Within the new Europe concept, the focus includes bundling the activities of the individual Nordmann locations, uncovering synergies and further optimising the expertise transfer. Here, customers benefit above all from a partner network throughout Europe. Through the European approach, Nordmann ensures that it is able to supply international customers with the right raw materials at the right time and in the right place even better in future.

■ Nordmann, Rassmann GmbH
www.nordmann.global

HDPE Recycling Plant in Mexico Starts Operation

■ The ALPLA Group has opened a new plant for HDPE plastic recycling in Toluca, Mexico. At the same time, the company has announced it will double its annual regrind material production capacity to 30,000 tonnes from the second half of 2022.

ALPLA celebrated the inauguration of its new state-of-the-art recycling plant for high-density polyethylene (HDPE) plastics in Toluca, the capital of the central Mexican State of Mexico, on 10 November. Among the guests were the Austrian ambassador to Mexico, Elisabeth Kehrer, and the governor of the State of México, Alfredo del Mazo Maza. Following the announcement of the plant's construction in September 2020, it took a little more than a year for the work to be completed. The investment sum came to around 20 million euros. Around 70 new jobs have been created at the plant, which will be run as a wholly owned subsidiary of ALPLA.

The facility is currently designed for an annual capacity of 15,000 tonnes of recycled HDPE (rHDPE) in pellet form. This regranulate is mainly used for the production of non-food packaging. The demand for recycling material is so high in Mexico and Central America that the majority of the output will be used regionally. With the initial start-up of the new recycling plant, ALPLA is staying true to its strategic focus of thinking ahead and investing in regions where the demand for recycled materials has a lot of growth potential.

The success of this strategy is evidenced by the fact that ALPLA can already announce an increase in the recycling plant's annual



ALPLA celebrated the inauguration of its new state-of-the-art recycling plant in Toluca, Mexico (Copyright: ALPLA)

production capacity to 30,000 tonnes starting in the second half of 2022.

In early 2021, the ALPLA Group announced that it would invest an average of 50 million euros a year until 2025 in the ongoing expansion of its recycling activities. In particular, it plans to globalise its activities in the area of high-quality recyclates in order to close the materials cycle in as many regions as possible. In all, the annual capacity of the ALPLA recycling companies, joint ventures and partnerships amounts to approximately 130,000 tonnes of PET and 60,000 tonnes of PE.

ALPLA Group
www.alpla.com

Production of Polymer Compounds in Turkey

■ Sumika Polymer Compounds Turkey (formerly Emaş Group), a predominant player in the Turkish compounding market, is now manufacturing the company's THERMOFIL HP® (high performance) polypropylene (PP) compounds directly for customers in Turkey and in countries bordering the Black Sea.

Sumika Polymer Compounds (SPC) Turkey is part of the company's European group structure itself a subsidiary of the Japanese group Sumitomo Chemical Co Ltd. manufacturing and supplying a wide range of thermoplastic compounds and polyolefin-

THERMOFIL HP® is an engineered short glass reinforced PP with performance features enabling it to replace polyamides (PA) and polybutylene terephthalates (PBT) and long-fibre PP predominantly in automotive, white goods and various industrial applications (Photo: SPC)



based elastomers. SPC Turkey has three compounding plants located in Gemlik, Bursa and Manisa.

The Turkish facilities, which were acquired early 2019, are well-established in mineral and recycled PP and production of THERMOFIL HP® will begin at the Gemlik plant. The implementation of additional compounding will increase SPC Turkey's overall production capacity to 60Kt per year.

THERMOFIL HP® is an engineered short glass reinforced PP with performance features enabling it to replace polyamides (PA) and polybutylene terephthalates (PBT) and long-fibre PP. The main benefits offered by THERMOFIL HP® include light-weighting and cost reduction, low density, improved strength and stiffness, creep impact resistance and easy processing.

Sumika Polymer Compounds is recognised for its sustainable and robust high performance PP resins which are predominantly used in automotive, white goods and various industrial applications and has manufacturing facilities providing local supply and support to customers in the United States, the UK, Thailand, China, Japan, India, France, and most recently in Poland.

Sumika Polymer Compounds Europe
www.sumikaeurope.com

Investment in Sustainable Production and Solutions

■ Sustainability plays a central role for the RKW Group. The RKW Group invests year-round and worldwide in modernizations and innovations in favor of sustainable products and processes. For the second time, the company and its approximately 3,000 employees have now also actively contributed to social commitment in a dedicated sustainability campaign.

The five-layer extrusion line commissioned in August at the Echte site, the latest of several investments in RKW's center of excellence for industrial packaging, exemplifies the RKW Group's commitment to modernization towards greater sustainability in production and solutions. As a result, the proportion of recycled raw materials can be continuously increased. Thanks to innovative formulations, the new equipment will also enable the production of high-quality plastic films with a high-recycled content and without any loss of quality in the future.

At the same time, the RKW Group is investing in both a new five-shift and a nine-shift plant with MDO (Machine Direction Orientation) at the Petersaurach site, which will go into operation at the beginning of 2022. The planned nine-layer machine will enable the production of MDO films with and without barrier properties.

The RKW Group has many years of experience in MDO technology and now offers MDO-PE solutions for packaging applications. A key component of this strategy is RKW Horizon – a 100 percent recyclable polyethylene (PE) MDO film for mono-material laminate packaging solutions. With the new nine-layer MDO plant at the Petersaurach site, the RKW Group is expanding its on-site production capacities and investing in this technology of the future.

RKW is going even further. To ensure that overall energy consumption is reduced, RKW is modernizing its production processes, relying on new, more efficient machines, and cooling systems with up-to-date measurement and control technology that demonstrably consume less energy and water.

Last year, the Group switched all its German sites to electricity from renewable energy sources. Since June 2021, the sites in France and Belgium have also been sourcing energy from renewable sources. In total, this is expected to save 100,000 tons of CO₂ per year. Other sites in Europe will also be converted in the near future.

Strategic development of the product portfolio

The RKW Group is committed to its responsibility as a plastics manufacturer and works continuously with its customers and partners to give plastics a sustainable perspective. In doing so, RKW is increasingly focusing on both the use of



Employees and management of RKW in Mannheim participated at the international RhineCleanUp Day for the second time, thus underlining their engagement for the community and society

recycled materials and the development of easily recyclable products.

With the further development of its innovative packaging solution for powdery goods, RKW ProVent, RKW is contributing to greater sustainability and resource conservation. The packaging solution consists of only one material, polyethylene, and can therefore be fully recycled. In addition, the plastic bags can also be produced in a CO₂-neutral way.

Living sustainability together

Not only the company, but also the 3,000 employees of the RKW Group actively contributed to more climate protection as part of this year's sustainability campaign. The RKW Group's 19 sites worldwide took part in the summer campaign with numerous environmental protection activities:

- RKW again took part in the Frankenthal "RhineCleanUp" this year. Together with the other participants, 25 colleagues from the Mannheim headquarters cleaned the banks of the Rhine – a total of 500 kg of waste was collected.
- At the sites in Wasserburg/Bavaria, Petersaurach/Bavaria and in Nordhorn/Lower Saxony, numerous employees took part in several trash collection campaigns.
- Used batteries were recycled at the RKW plant in Guangzhou/China from August 2020 to August 2021.

Certifications as Reusable Materials in the Recycling Stream

■ As a constituent of flexible multi-layer films for stand-up pouches, TOPAS® cyclic olefin copolymers (COC) from TOPAS Advanced Polymers are compatible with polyethylene film recycling streams. This has now been confirmed by the Association of Plastic Recyclers (APR) in the form of a Critical Guidance Recognition. The tests were carried out on stand-up

Multi-layer films for stand-up pouches containing 15.5 % TOPAS® cyclic olefin copolymer (COC) are suitable for recycling in PE waste streams, confirms the APR (© PantherMedia/3DMAVR)



pouch film containing the grades TOPAS® 9506F-500, 8007F-600, 7010F-600 und 6013F-04 with a content of 15.5 %. They comply with or exceed the Critical Guidance Protocol of the APR for PE film and flexible packaging, path 1 (FPE-CG-01). In 2020, the APR had already tested high-gloss HDPE containers with an outer layer of 20 % TOPAS® 8007F-600 and issued a confirmation of compliance. Apart from that, TOPAS® COC was certified as a reusable polyolefin within the framework of the EU initiative for a circular economy for the recycling paths 1, 3 and 7.

TOPAS Advanced Polymers and the parent company Polyplastics are working together with leading global film manufacturers and brands on the development of recyclable packaging applications. Dr. Dirk Heukelbach, Market Development EMEA at Topas Advanced Polymers: "These certifications in Europe and the US are an important step for brand owners, producers and converters who are on the lookout for recyclable packaging solutions. COC thus proves to be a highly effective material option that can be used as a strategic component to comply with today's comprehensive sustainability requirements."

■ Association of Plastic Recyclers (APR)
www.plasticsrecycling.org

TOPAS Advanced Polymers GmbH
topas.com

New Universal Control Unit

■ The new OmniControl unit allows the comprehensive control of a complete vacuum system using just one device. It combines the control of the total pressure with the control of the pumps. The unit communicates with products that support the Pfeiffer Vacuum RS-485 protocol (e.g. HiPace, HiScroll, HiLobe, MVP and DigiLine). This makes it possible to exchange and process data between various Pfeiffer Vacuum products without any difficulty and without having to invest

Pfeiffer Vacuum control unit OmniControl



in additional devices. Optional gauges from the ActiveLine range (with analog output) can also be connected. The 3.5" touch screen with an intuitive user interface ensures easy and convenient control of the vacuum system. For example, a button for switching the devices on and off can be added. The total pressure and the pump parameters (RPM, power input etc.) can be displayed at the same time.

The basic version of the OmniControl is available with or without an internal power supply. Devices without a power supply are available as a rack mountable or mobile device for manual operation. This means that the control unit can be used either locally or at various locations. Rack mountable devices are also available with an optional table holder.

With the Gauge/IO option, there is no need for a separate vacuum gauge controller. Various inputs and outputs are provided for connecting external components.

With the Data option, the measured values can also be saved as a CSV file on a USB stick or a MicroSD card.

■ Pfeiffer Vacuum GmbH
www.pfeiffer-vacuum.com

Small and Flexible – Alpha Plus Extruders for Roller Blind Producer

The French company SPPF based in Cholet Cedex produces 350,000 roller blind boxes and roller blinds per year and is thus known as a specialist in standard and customized PVC system solutions for windows. To extend its production capacity, battenfeld-cincinnati Austria GmbH from Vienna recently delivered a total of three alpha plus extruders with 60 mm diameter to the profile manufacturer. The customer is enthusiastic about this new version of the standard extruder model with BCtouch UX compact control



20 years ago, battenfeld-cincinnati launched alpha, a product line with a completely new concept: a compact, standardized extruder series to make small technical profiles and pipes available at an attractive price without delivery times. The sales success of this article has continued unabated ever since. The extruder specialist responded by adding the alpha plus to the range at the K 2019. Technically speaking, it is still the familiar high-tech plug & play extruder model, but this time plus the new BCtouch UX compact control system. "With its easy, intuitive operation, this control system facilitates daily production work for our machine operators", says Guillaume Le Roc'h, Production Manager at SPPF. Similar to its large sister, the BCtouch UX control system already long-established in the market, this new control system scores by its clear display of all required features on a 12" screen. Pop-ups for settings and data input allow operation almost without any previous knowledge. A highly sensitive temperature monitoring facility is also integrated in this compact control system, which is of special advantage where thermally sensitive materials are processed.

Alpha extruders are available in sizes of 45, 60 and 75 mm as basic models, as well as with finely or coarsely grooved feed zones according to customers' choice. They are

equipped with a Knödler drive system as standard and come with an extremely compact design thanks to a highly sophisticated substructure. SPPF chose the 60 mm version with a smooth feed zone and is very pleased with the new extruders. Guillaume Le Roc'h comments: "The extruders show high-quality workmanship and are consequently very reliable. Thanks to their compact footprint, they are also suitable for flexible use, which is very important in view of our extensive product portfolio." Of course, the sales price was also an important sales argument for the roller blind manufacturer. After all, the very combination of the extruders' technical features with attractive pricing continues to win customers worldwide. More than 1,300 alpha extruders have been sold, 30 of which are plus models.

battenfeld-cincinnati Austria GmbH
Laxenburger Str. 246, A-1230 Vienna, Austria
www.battenfeld-cincinnati.com

24th International Trade Fair
for Plastics and Rubber



25 – 28 JAN
2022
MOSCOW
R U S S I A



interplastica.de

MEMBER OF



YOUR GLOBAL GATE
FOR PLASTICS AND RUBBER

k-globalgate.com

powered by:



Messe
Düsseldorf

“The PURITY SCANNER ADVANCED is used where other sorting systems have difficulties”

Lars Ruttmann, Managing Director at SORTCO, presents SIKORA's PURITY SCANNER ADVANCED for inspection and sorting of plastic pellets



SORTCO relies on SIKORA's online inspection and sorting system for highest material purity in contract sorting

SORTCO GmbH & Co. KG is a specialist for optical and mechanical sorting of shape and color deviations in plastic pellets. In addition, the company offers dust removal and metal separation of plastic raw materials. Since March 2021, SORTCO has been using two PURITY SCANNER ADVANCED systems from SIKORA in its new, state-of-the-art sorting service center in Niedertzissen/Rhineland-Palatinate, Germany. With these, the pellets to be sorted are inspected 100 % optically and impurities from a size of 50 µm are automatically sorted out

Technically demanding plastics, such as those used in the medical sector or in the aircraft and automotive industries, require the highest quality standards as well as reliable control and processing of raw materials. Accordingly, the requirements for the purity of the materials are very high. SORTCO has been specialized in contract sorting since 2015 and professionally

prepares plastic pellets according to customer requirements.

In the sorting service center, which was opened in spring 2021, the company sorts standard plastics as well as optically demanding technical plastics. For this purpose, SORTCO uses two online inspection and sorting systems from SIKORA. “The decision for SIKORA was made due to the best

detection for us, an excellent analytics and the proximity to the company, which is not unimportant for us,” says Hilger Groß, Head of Sales & QM at SORTCO, and continues: “The PURITY SCANNER ADVANCED is typically used where other sorting systems have difficulties. Namely, in the detection of very small optical defects from a size of 50 µm.” SORTCO uses

the PURITY SCANNER ADVANCED to sort primarily transparent, natural-colored and, to a lesser extent, colored pellets. The focus is on unreinforced materials which, after sorting, find their use in high-quality optical applications. Each system is equipped with 3 optical cameras, which detect even the smallest optical impurities from 50 µm in size and automatically sort them out by compressed air pulse. If required, the PURITY SCANNER ADVANCED can also be extended by an X-ray camera for the detection of metal particles in the raw material.

"Black specks are the focus of our sorting work. In addition, we remove all discolorations that have a different color than the polymer to be sorted," explains Groß and continues: "As a service provider, SORTCO is confronted with new materials and new and old contamination every day. This means that we also have to adjust the PURITY SCANNER ADVANCED to constantly changing products and customer requirements. We therefore create a special recipe for each product that can also be used and adapted for future jobs." During sorting, the PURITY SCANNER ADVANCED automatically records the number of all defects, the smallest edge length of the op-

Plastic pellets are optically inspected and sorted by the PURITY SCANNER ADVANCED



tical defect, the contamination area and, for example, the size class of the defect, which can be freely adjusted and specified according to customer requirements. In addition, the system detects the intensity with which the color deviation was detected. "All key data is checked again at the end of the job, stored and a test report is generated for the customer. Logging of the results is also possible but must be decided due to the large volume of data," sums up Lars Ruttmann, Managing Director at SORTCO.

"Our customers appreciate that we understand their problem about the cause and effect of the defect, i.e. we dispose of plastics know-how, offer the appropriate solution and take over all the work necessary to produce the optimal quality," summarizes Groß, adding, "By commissioning optical sorting, our customers contribute to a very significant extent to protecting our environment and avoiding waste." He advises interested customers for whom sorting is an option to take a closer look at products that have recently shown higher reclamation costs. "It is comparatively easy to calculate a comparison between sorting costs and potential savings. However, if the customer also takes into account his lost sales, his loss of image and all the costs for unnecessarily consumed resources such as energy, machines, personnel, materials, freight, etc., many people get very wide-eyed. The advantages of sorting always outweigh the disadvantages," concludes Groß.

Ruttmann also sees an increasing demand for optically sorted raw materials in the future. "Sorting is in demand because manufacturers have recognized that special requirements also necessitate special measures. We are pleased to have found such a reliable partner in SIKORA and its sorting system, with whom we successfully cooperate in our core business."

SIKORA AG
Bruchweide 2, 28307 Bremen, Germany
www.sikora.net



IN SPECT MORE



Optical Inline Inspection
of extruded products

Small-
budget
solutions

Surface.
Geometry.
All-In-One.

www.pixargus.com

Quality Control Made Easy

Professional quality control is required wherever something is produced, including, of course, in film extrusion. However, the demands on such instruments have changed, it has to be efficient, precise and easy to operate without having to undergo extensive training

At the K 2019, KÜNDIG presented their offline thickness gauge Filmtest in its third generation. The Filmtest 3G has established itself on the market in the meantime, new functions being added continuously.

New feature: Sheet Weight (ISO 4591)

In many labs, the quality of the film is checked by cutting and measuring circular areas. The measured values of the circular areas from a sample must not exceed a specified tolerance band. The new Sheet Weight function, which has been included in the Filmtest 3G Quality Analyzer software this summer, calculates these measured values gravimetrically, according to ISO standard 4591.

The Profile Genius function has been part of the Quality Analyzer since the beginning. A harmonic analysis helps to significantly improve the film quality. The graphic (Chart 3) shows a thickness profile that was analyzed with the Profile Genius function.

The measurement process is very simple: the target values are entered or imported, the film sample is automatically transported through the measuring unit and then falls into the basket of the scale. Afterwards, the thickness

Chart 1: This film sample has a length of 920 mm and a thickness of 3 μm . The software calculates, with the currently selected settings, the following measuring values for 8 circular areas



Chart 2: The number of circular areas can be specified according to the sample length, or the software automatically determines as many circular areas as possible from the respective film sample

Sample Number	Weight	Avg. Sample Thickness	Sample Area	Area Weight	Volume
1	1,01 g	124,9 μm	99,7 cm^2	101,354 g/m^2	1,246 cm^3
2	1,02 g	125,7 μm	99,7 cm^2	101,991 g/m^2	1,254 cm^3
3	1,01 g	124,3 μm	99,7 cm^2	101,814 g/m^2	1,246 cm^3
4	1,01 g	124,3 μm	99,7 cm^2	101,776 g/m^2	1,239 cm^3
5	1,01 g	123,7 μm	99,7 cm^2	101,361 g/m^2	1,234 cm^3
6	1,01 g	124,8 μm	99,7 cm^2	101,399 g/m^2	1,244 cm^3
7	1,02 g	125,6 μm	99,7 cm^2	101,896 g/m^2	1,253 cm^3
8	1,02 g	125,7 μm	99,7 cm^2	101,999 g/m^2	1,254 cm^3
N = 8		$\bar{\mu} = 124,9 \mu\text{m}$		$\bar{\rho} = 101,299 \text{ g}/\text{m}^2$	

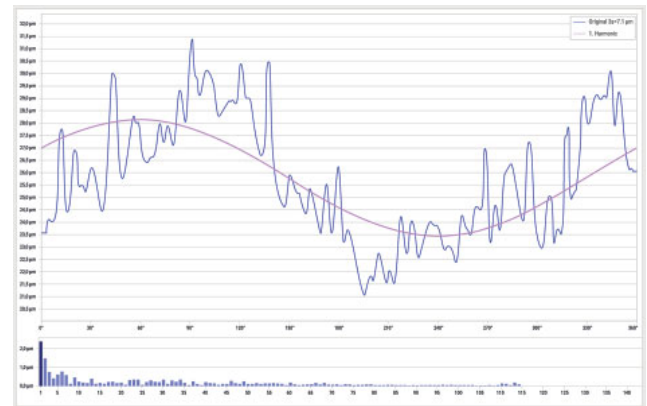

Chart 3: This chart shows clearly that the biggest disturbance in the profile is the first harmonic, represented by the purple graph. The profile tolerances could be significantly reduced by centering the die

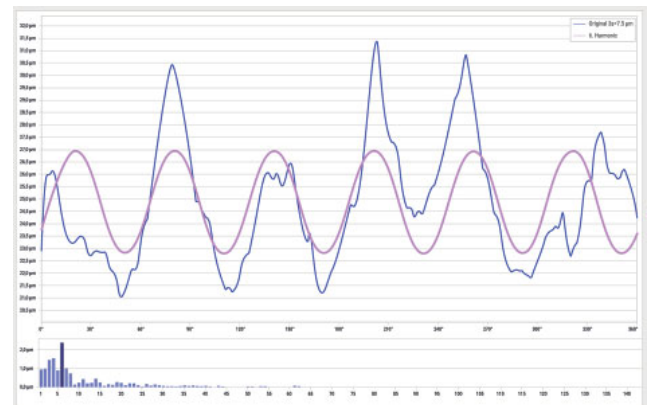

Chart 4: This example shows a large influence of the 6th harmonic. Possible reasons could be: an air ring that does not distribute the air evenly, or a calibration cage that pushes too much into the bubble

profile, the square meter weight, the harmonic analysis and the measured values of the circular areas are calculated and graphically displayed.

Other useful functions include automatic export of the measurements, synchronisation of the production data with the existing job management, and access to the measured values anytime and anywhere, if desired. Simple, precise and efficient, that's the Filmtest 3G.

HCH. KÜNDIG & CIE. AG
 Joweid Zentrum 11, P.O. Box 526, 8630 Rüti ZH, Switzerland
www.gauge.ch

In August 2021 Starlinger & Co GmbH received two Letters of No Objection (LNO) issued by the US Food and Drug Administration FDA regarding its newly developed machine concept for processing post-consumer HDPE scrap. The LNOs apply to the HDPE bottle-to-bottle and cap-to-cap recycling processes respectively, and confirm that HDPE regranulate produced with the Starlinger recycling process can be used at levels of up to 100 % in packaging with food contact. Already in 2012 Starlinger received its first FDA LNO for the use of recycled HDPE

rHDPE pellets produced from milk bottles and canisters



100 % rHDPE –

FDA Gives Green Light for Recycling Process

“The two LNOs are another important achievement for Starlinger in the field of food grade recycling”, said Paul Niedl, Commercial Head of Starlinger recycling technology. “Like it is the case with PET, 100 % recycled HDPE can now be used in applications with direct food contact. There is keen market interest for this – all signs are pointing towards a circular economy.”

An elementary step: Odour reduction

The new Starlinger machine concept consists of a recoSTAR dynamic recycling line with a C-VAC degassing module and downstream odour reduction technology. The removal of odours plays an important role in the production of food-grade recyclate made from post-consumer HDPE. “Packaging made of HDPE is used for a lot of foods”, explained Niedl. “If,

for example, substances from food scraps migrate into the plastic, they can cause unpleasant smells in the recycling process. To avoid this, we use our three-step procedure: It starts with material preparation, followed by highly efficient degassing in the C-VAC module, and is finalized with the thermal after-treatment of the produced regranulate. This method ensures that even deeply embedded odours are removed.” Contrary to methods which bind the odours by means of additives and enclose them in the regranulate, the Starlinger process removes the substances causing the odours and delivers permanently odour-reduced pellets which do not release unwanted



HDPE milk bottles

smells in the following production steps.

“With the development of the circular economy, HDPE bottle-to-bottle recycling will gain increasing importance”, emphasised Paul Niedl. “A big share of food packaging such as milk and juice bottles, bottle caps as well as food trays for meat is made of HDPE. If this packaging is returned to the recycling stream and reused as food packaging without downcycling, millions of tons of virgin HDPE can be saved in the future.”

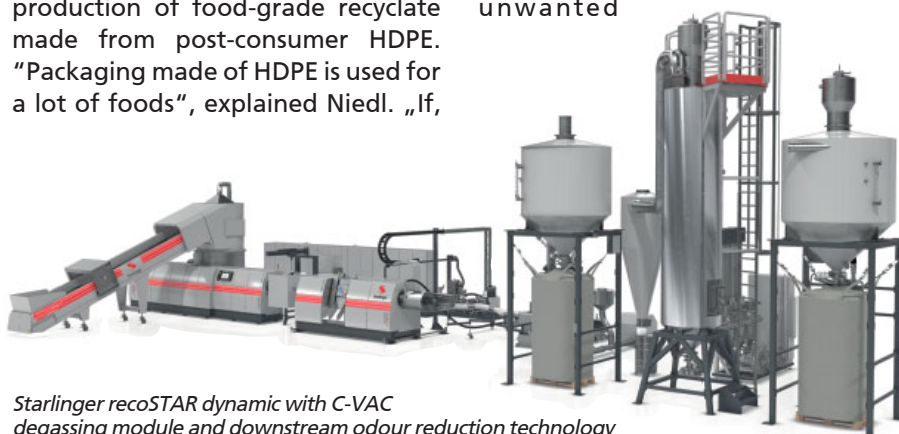

Starlinger recoSTAR dynamic with C-VAC degassing module and downstream odour reduction technology

▶ **Starlinger recycling technology**
Furtherstr. 47, 2564 Weissenbach, Austria
www.recycling.starlinger.com

Front and center are cost-effective system solutions for medical technology, logistics packaging, technical appliances and lightweight construction, which allow for a measurable increase in efficiency and sustainability, for example through the use of high percentages of recycled material

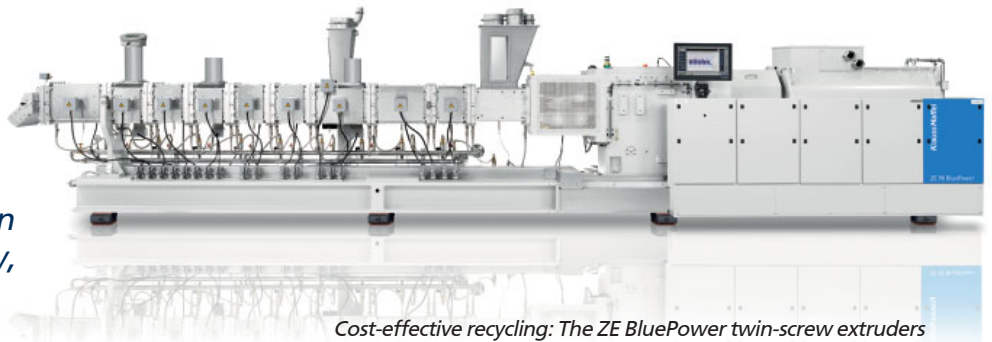

Cost-effective recycling: The ZE BluePower twin-screw extruders are ideal for the recycling steps of plasticizing, degassing as well as re-pelletizing and re-compounding (Photos: KraussMaffei)

“Efficiency meets Sustainability”

“As a comprehensive solution provider, our goal is to support our customers sustainably in achieving business success. We combine our machine and application technologies with suitable digital solutions and products to generate clear added value for our customers along the entire value chain,” says Dr. Volker Nilles, Executive Vice President of the New Machines division at KraussMaffei. Consequently, the solutions presented at Fakuma are completely geared toward “Efficiency meets sustainability” and have a clear focus on output maximization, high product quality, reduction of life cycle costs and ensuring sustainability.

This year, KraussMaffei has made the conscious decision to have an all-digital presentation at Fakuma. “Since the situation has become challenging due to the COVID pandemic, we decided on this kind of trade show appearance early on and used the time to strengthen contact with our customers through digital Pioneers!Talks, road shows and persona conversations,” says Nadine Despineux, Executive Vice President of the Digital and Service Solutions division.

Production monitoring at any time and anywhere: socialProduction as a desktop, smartphone and tablet application



Secure remote support is one click away: smartAssist as a desktop, smartphone and tablet application

Digital solutions with customer benefits throughout the lifecycle

Digital solutions from KraussMaffei stand for a high machine availability, high product quality and low manufacturing costs, thus allowing a competitive edge to be gained. At Fakuma, KraussMaffei demonstrated new solutions for customer interaction along the entire value chain.

The cloud-based remoteSupport solution supports all series and technologies from KraussMaffei in any place and at any time. This does not only minimize downtimes, but also service costs. In addition to remote service (remoteAccess) for the machine control system, smartAssist is a video-collaboration app that adds intuitive human-to-human communication. Interactive AR annotations allow even complex tasks to be shown and explained via smartphone, tablet, computer or smartglasses.

The pioneersClub is KraussMaffei’s “digital window”. Customers worldwide take advantage of an easy and transparent access to digitalized data such as individualized documentation of the customer’s machines, electronic tutorials for machine series as well as quick and

easy availability checks and ordering for spare parts and retrofits.

Make plastic green – Highly efficient extrusion technology for recycling tasks

Extrusion lines from KraussMaffei are particularly efficient for recycling tasks. They score with excellent melt homogeneity, a reduction of obtrusive odors and the targeted upcycling.

Machine documentation and spare parts procurement, 24/7: The digital pioneersClub service platform



EdelweissCompounding systems are an economic solution for recycling and compounding segregated post-consumer plastics. The ZE BluePower are distinguished by their increased volume and a high specific torque, which allows them to pick up and process the large-volume waste flawlessly. The result is maximum throughput with high quality.

ZE BluePower twin-screw extruders also provide the option for sustainable solvent-based plastics recycling. The objective of this is solvent-free recycled material that can be enhanced like virgin material. Through openings in the housing and a vacuum applied to them, the extruders safely extract the solvents from the melt. Depending on the requirements for the polymer being created, the process involves varying degrees of refinement. For instance, if you want to reduce the residual solvent content in the material from the original 30 down to 2 percent, a twin-screw extruder is sufficient. If degrees of purity in the ppm range must be reached, a twin-stage cascade is recommended.

KraussMaffei Technologies GmbH
www.kraussmaffe.com



Ultimate Product Protection, Especially Sustainable *ProVent® for Bulk Materials – 100 Percent Recyclable*

Sustainable because fully recyclable: RKW ProVent® is an innovative packaging solution for powdery goods that features reliable protection against moisture and high tear strength

RKW ProVent® thus stands for reliable product protection and three times longer shelf life compared to conventional bags. The water vapor barrier is even 40 times more effective than paper-based packaging. The bottom line is more durability and fewer losses due to incorrect storage.

Above all, RKW ProVent® contributes to greater sustainability and resource conservation. Unlike non-recyclable paper bags made of composite materials, the innovative packaging solution consists of only one material, polyethylene. It can therefore be fully recycled. In addition, the RKW Group has been consistently reducing film thickness for years – another contribution to the most economical use of valuable natural resources.

In addition to the complete recyclability of ProVent®, the packaging can also be produced in a CO₂-neutral manner if required. In addition, the proportion of recycled plastics in RKW ProVent® is currently increasing to up to 50 percent. To further improve the eco-balance of RKW's products, the company uses only electricity from renewable energy sources in Germany, France and Belgium. The other sites are also gradually being converted to green electricity. Products that, like ProVent®, can be recycled and are made from recycled materials will in future be marketed by RKW under the Ecore label.

Safe and fast processing

For many customers, high throughput with a reliably stable filling process is important, as Axel Ritz, Sales Manager Export & Industrial Customers Knauf Building Products, confirms:

“We have rebuilt our machinery and wanted to take this opportunity to increase output. The ProVent® bag is supplied on a roll, it is possible to change bags more quickly, we can therefore produce much more flexibly and save storage space.”

RKW ProVent® is already being used successfully in the construction materials, food and chemical industries – in other words, wherever moisture-sensitive bulk materials and powders are filled on an industrial scale. Since 2019, the main production site of RKW ProVent® – Echte – has been BRC-certified and thus the bags are approved for food contact.

The drastically better moisture barrier of RKW ProVent® compared to paper bags gives users many advantages: “Another great advantage is that, unlike normal paper sacks, filled plastic sacks such as the RKW ProVent® can also be stored outdoors. Even when stored in different climatic zones, the bags remain absolutely leak-proof; also in climatically challenging countries with high humidity, outdoor storage is not a problem,” says Axel Ritz, Sales Manager Export & Industrial Customers Knauf Building Products.

Plastic packaging with reliable self-venting system

Packaging for powdery goods must master another challenge in addition to product protection and sustainability: powdery goods bind a lot of air, which leads to the formation of air bubbles over time. These air bubbles impair transport stability and often damage the packaging. RKW ProVent® has a reliable, integrated and patented self-venting system.



Plastic bags as a marketing tool

In addition to physical protection, one of the key functions of packaging is to influence end-user purchasing decisions and increase brand awareness through its eye-catching appearance. The younger generations of the RKW-ProVent® packaging line feature the Air Vent 2.0 system.

The system leaves plenty of room for branding opportunities because the vent system is fully integrated, making the front of the package completely seamless. As a result, the entire surface can be printed with up to eight colors. RKW ProVent® thus meets the high demands of brand manufacturers who do not want to compromise either design or print quality. “As a premium supplier, it is important to us that we offer a clean solution at the point of sale, in other words: that our products are robustly packaged and dust-tight. You can buy our bags in a suit without getting dirty. The printed image is also high-quality and our products come across as premium goods,” says Axel Ritz from Knauf.

RKW Group, RKW SE
Havellandstr. 8, 68309 Mannheim,
Germany
www.rkw-group.com

Machinery and plant engineering expert BHS-Sonthofen has expanded its test center at the Sonthofen, Germany, site and has undergone modernization work in the areas of recycling and environmental technology. BHS conducts tests with shredding, sorting, and conveyor technology for the recycling industry and environmental technology in a space that spans nearly 1,000 square meters. This allows BHS to offer its customers the option of testing all process steps

Every input material is different: This makes it all the more important for BHS and its customers to carry out extensive tests together



Complete Process Solutions for Recycling Technology to Test Center Added

When it comes to recycling and the environment, no two input materials are ever the same. That is why it is imperative that recycling companies conduct extensive tests with the respective input material before deciding on a specific plant layout. At its company headquarters in Sonthofen, Germany, BHS offers customers and interested parties in the area of recycling the opportunity to conduct comprehensive tests using their own input materials. Magnets, screening, and various separating tables provide the right technology for sorting shredded products.

“As a leading process consultant and mechanical process technology provider, it is our responsibility to develop all-in-one solutions together with our customers that are perfectly adapted to their needs,” explains Steffen Hinderer, Director Process Development at BHS-Sonthofen. “Our test center, which opened in summer 2019, has already raised the bar in the areas of mixing, shredding, recycling, and filtering. Thanks to the expansion of the recycling and environment test division, our customers are able to test all their processes in this area even more comprehensively in our facilities.”

Turnkey systems for improved overall process efficiency

In addition to optimizing the conveyor technology, investments for the expanded area of recycling also include sorting machines that perfectly complement the process expertise

In the expanded test center in Sonthofen, BHS customers can test every step of the recycling process

The entire recycling process – from input material to finished products – can be tested at the BHS test center



BHS Control Systems offers customized control systems for recycling plants

of BHS-Sonthofen. Dryers and mixers can also be installed upon request. “Our customers can now test their entire recycling processes, all the way from the input material to finished products on-site at our facilities. Our “one-stop shop” approach allows you to test your complete systems in a time and cost-efficient manner,” explains Steffen Hinderer.

In the expanded test center, customers will also be able to gain an impression of suitable plant control systems for the area of recycling and environment. This involves control systems for complete plants from BHS Control Systems, which are specifically tailored to the requirements of the customer. The user benefits from the base software’s open interface architecture: the Win CC Open Architecture. The scalable system allows the wide range of components to be integrated smoothly and therefore the plant control systems can be expanded as required and without large investments.

BHS-Sonthofen GmbH
 An der Eisenschmelze 47. 87527 Sonthofen, Germany
www.bhs-sonthofen.de

“PRT Targu Mures” Joint Venture Promotes a Bottle-to-Bottle Cycle

The ALPLA Group, the global packaging solutions and recycling specialist, is investing in the construction of a recycling plant in Targu Mures, Romania as part of a joint venture with its partners. The plastic granulate recycled there in the future will come from PET bottles collected from household waste and will be used to manufacture new PET bottles



By establishing a joint venture called PET Recycling Team Targu Mures, ALPLA and companies Ecohelp and UPT are investing in the construction of a recycling plant for PET (Copyright: ALPLA)

By creating the planned PET Recycling Team Targu Mures joint venture, ALPLA and companies Ecohelp SRL (Romania) and United Polymer Trading AG (Switzerland) are each investing equally in the installation of an extrusion line to recycle post-consumer PET bottles at the Romanian partner's site. They aim to produce 15,000 tonnes of food-grade post-consumer recycled PET (rPET) each year. The rPET granulate will then be used to manufacture new preforms and bottles, with an intention to strengthen the local materials cycle within the Central and South-Eastern Europe region.

Three partners, three different areas of expertise

The three partners contribute different areas of expertise to the joint venture. While ALPLA acts as a recycling specialist and a preform and bottle manufacturer, Ecohelp supplies base material in the form of PET flakes that will go through an extrusion process to produce high-grade rPET granules. UPT in turn co-owns the rPET Upcycling facility Cumapol Emmen in The Netherlands and specialises in trading plastics and recycled material. The entire amount being invested in the plant and the associated building and infrastructure comes to roughly

€7.5 million. The plant expansion will create 15 new jobs at the site in Targu Mures.

Supporting the local circular economy

ALPLA Chairman Günther Lehner, who is responsible for developing the company's Sustainability and Circular Economy departments, emphasises the significance of the investment: „Our aim at ALPLA now and in the future is to establish a bottle-to-bottle cycle – including in regions in which the collection and recycling of waste still has potential for development. By participating in this joint venture, we are taking a strategically



The recycled PET will come from PET bottles collected from household waste and will be used to manufacture new bottles (Copyright: ALPLA)

local material cycles give us an opportunity to boost investment projects like these. With our two partners, we have brought together our different areas of expertise and are looking forward to a new form of collaboration."

Rainer Widmar, Regional Manager CEE at ALPLA, emphasizes the relevance for local customer relationships: „With this investment, we are bringing our recycling expertise to our customers in the region, letting us operate within the market at even closer proximity."

The joint venture is subject to regulatory approval by competition authorities. The parties signed the contract for it on 9 September 2021, with production planned to commence in mid-2022.

important and sustainable step in this direction." Georg Lässer, Head of Corporate Recycling at ALPLA, adds, „We are seeing

consistent growing demand from our customers for recycled material, and this demand is worldwide and unbroken. It and our customers' need to close

ALPLA Werke Alwin Lehner GmbH & Co KG
Mockenstr. 34, 6971 Hard, Austria
www.alpla.com

SMART EXTRUSION

The only website collecting information about smart technologies of extrusion

34 600 + average monthly visits

Geographic distribution of Smart_Extrusion readers, %

- Germany
- Austria and Switzerland
- Italy
- Eastern Europe
- Benelux countries
- Scandinavia

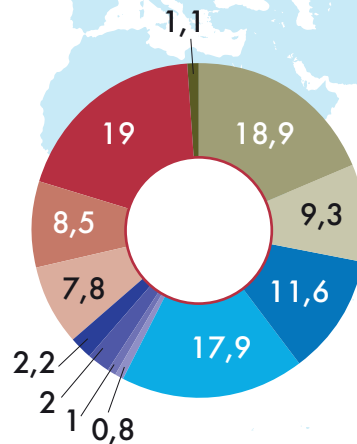

- Other
- Asia
- Russia
- South America
- North America
- Other Europe

Celebrating 70 Years of a Family Business

As Vetaphone passes another significant milestone in its history, owners Frank and Jan Eisby give a personal insight to Nick Coombes about the early days of the company and how their Father, Verner, became one of the great pioneers in the printing and converting industries

Nick Coombes: *Can we go back to the very beginning – how and where did it all happen?*

Frank Eisby: It all started 70 years ago in Kolding when my Father was speaking with a printer who was having problems getting ink to adhere to the new plastic packaging materials that were becoming popular in the early 1950s. Most people the printer asked had no idea how to solve the problem, but Verner, who was an electronics engineer, was accustomed to working with high voltage bulbs and broadcasting systems – and because he was something of an inventor, was keen to accept the challenge and set about finding a solution in his workshop.

What was it like growing up with an inventor in the household?

Jan Eisby: Very busy! My parents worked around the clock – my Father ran his business during the day and spent all night inventing and building things. Our Mother, Grethe, looked after the finances to make sure the family always had food on the table. In fact, they were so committed to their work that even our family holidays were combined with visiting customers throughout Europe. We had an interesting but different childhood!

How did the company come to be called Vetaphone?

Jan: That goes back even further to Verner's schooldays, when along with a friend called Tage, he was building speakers and amplifiers for parties and the music business. One of the hottest technologies at the time was phonics, especially ship to shore radio, so they took the 'Ve' from Verner and the 'Ta' from Tage and added 'phone' to get the name Vetaphone – it's as simple as that!

What was driving the demand for surface treatment in the early days?

Frank: The brand owners were wanting to add more colour to their packaging especially in the food sector, where the new plastic materials were giving a longer shelf life to their products. More colour also added customer appeal to their branded goods. Remember, we're talking about the time when most food items were still being sold loose and were not packaged.

How did Vetaphone cope with this?

Jan: I think the early days were chaotic! Verner had invented a process that everybody wanted, but nobody knew how or why it worked, which made it very difficult to sell to the industry. So, he spent 12 years travel-



The sons of the founder reminisce on 70 years of Vetaphone history

ling around the World visiting various universities and institutes explaining the process and finally came up with the corona treatment theory – and it's still the fundamental principle of what we do today.

What have been the major milestones along the way?

Frank: Without doubt, creating the corona discharge, because it's central to the process. But it's also the way we have managed to explain the theory behind the technology and convince people of its value. This has been essential to Vetaphone taking corona treatment from a workshop experiment to a viable commercial process. Equally, an understanding of the different substrates has been important to developing the correct treatment – we call it watt density now, but it

was originally known as e-norm. All of these put together with the development of electronics have been significant steps along the way.

You have spoken about your Father and the part he played – where do you two fit into the overall picture?

Jan: We both started as apprentices learning as much of the overall process as we could and steadily made our way up the ladder in both the good and the bad times the company went through. Frank is now CEO, and the guy with a clear vision of the future and in charge of the strategy to get us where we want to go, and I'm the CSO with the responsibility of looking after our worldwide customer base through a team of Area Sales Managers and network of agents spread over 60 different countries.

In your time with the company, what major changes have you seen in the market?

Frank: Too many to list overall, but if we look at more recent times, on the technology side it's been the advance in electronics and the ability this gives us to apply a powerful electrical discharge to sensitive substrates at very close range. This has been matched by the development of more complex substrates with sometimes challenging properties that are now being used for packaging purposes. For example, customers are now looking for special coatings and effects, so we must gear our R&D to respond to these changes in market demand.

How have you taken the company from a small family business to a market leader?

Frank: It's all about careful planning. We've just been through an exciting period in our development, despite the problems posed by the COVID-19 pandemic! Since 2017 we've invested in a new high-tech HQ here in Kolding – last year we opened our Test Lab, which is a unique global facility in this industry – and most recently we have commissioned a fully equipped

showroom where we can demonstrate the latest technology to customers either in person or by video link. All these investments have been market driven and highlight our flexible approach to any new situation. It allows us to develop new products in partnership with our customers and test them in the Lab before they commit to the expense of commercial production.

You have always maintained that Vetaphone's people are its greatest asset – why do you say that and how does it work?

Frank: We realise that everyone is different and that no single person can run a company. This sets the framework for how we operate here, with every member of staff engaging with the concept that they play an important part in the company's success. By empowering them in their own jobs, we benefit from their ideas on how to improve work processes and make the company more productive – they all want to be part of a successful business and we've managed to do it in a typically Danish way by creating a strong team-spirit.

Looking outside the company, why does Vetaphone believe so strongly in educating the market?

Jan: Because we know there is still a limited understanding of surface treatment technology and the corona process. It's still true to say that many companies know they need it, but they don't know why, or what it can do for them. Corona is not a 'set and forget' process because not all jobs and substrates are the same, so it's our job to teach them how it works and how to control it – and if it stops working, they need to know who they can ask for help. In addition, as new applications come onto the market and new manufacturers enter the production chain, they are faced with the same issues and have the same questions that we have been asked to solve many times before – so education is an ongoing process. By sharing our knowledge,

we empower our customers to improve their productivity.

If we look ahead from this year's 70th Anniversary, what plans do you have for continuing the company's success in the global market?

Frank: First of all, I'd like to say how proud we are of what the company and the whole Vetaphone family has achieved up to now – it's a privilege to be leading such a dynamic and successful team. Looking ahead, I can see that market demand for our customers' products will continue to grow, so we are here for the long term too. All demand projections for labels and printed packaging are upwards and as new materials are developed and employed, our technology will play a major part in securing success for manufacturers by working to develop strategic partnerships.

Do you see a growing importance in these partnerships?

Jan: Yes, no question about that. Our partners are already working hard with us to develop more environmentally friendly packaging using bio-degradable and easier to recycle materials, like mono-layer plastic films with special plasma coatings, but there are many more examples. Vetaphone will continue to play an integral role in finding these new solutions, and we have the unique knowledge and experience that allows us to adapt to these challenges.

Overall, what would you say has been your greatest achievement?

Frank: From a personal point of view, I'm really proud of the way we support our worldwide customer base with the latest technology that improves their efficiency and end products – and we do it with a company culture that makes it fun to go to work!



Pioneering Proof of Concept to Help Close the Loop for Digitally Printed Pouches

Within a cooperation project the key industry players Dow Packaging and Specialty Plastics (P&SP), a business unit of Dow, HP Indigo, Cadel Deinking and Karlville together with Reifenhäuser, announced the successful delivery of the first-of-its-kind pouch-to-pouch mechanical recycling concept

The approach uses a multi-stage process to contribute to a circular economy for digitally printed pouches. Starting with a polyethylene (PE)-based barrier food pouch designed for recyclability, the project team have used mechanical recycling and deinking to create a high-quality dishwasher MDO-PE pouch containing 30 percent recycled contents and being itself suitable for recycling.

In a next step, the team is working on the digital product passport R-Cycle to allow for recycling-relevant packaging properties to be recorded and to make the pouch identifiable for high-quality recycling within post-consumer waste management.

Optimal recycling output

Delivering the high-quality PE-pouch has required several steps in a coordinated process with each team member applying their experience and capabilities collaboratively: "The requirements for plastic packaging products have never been more complex than today. And we have modified and enhanced our Reifenhäuser production lines to enable films and packages not just to be economical and

functional, but to meet the vast demand for recyclable packaging based on mono-material structures", commented Ralf Wiechmann, Head of Film Innovation at Reifenhäuser. "For this project we've broadened our machinery expertise to co-extrude the new resins on our highly flexible EVO 9-layer blown film line and produce PE-based packaging films at fast line speeds. This project shows that we can successfully both produce recyclable packaging, according to Recyclass and CEFLEX guidelines, and use recycled materials in high value applications if we collaborate effectively along the value chain."

Next step: closing the loop for traceability

As a further evolution of the project, the companies are working to add digital traceability to the pouches in line with R-Cycle, a cross-company initiative to develop an open and globally applicable traceability standard for sustainable plastic packaging. The aim of this initiative is to automatically record recycling-relevant packaging properties during production by providing a digital product passport and to pass them on through the value chain. Using special markings, recycling-friendly packaging can then be identified in the recycling process and sorted into single-type fractions. This is the key to obtaining high-quality recyclates in order to continue efforts to close the loop. R-Cycle is being driven by several major stakeholders in the plastics industry, including Reifenhäuser, which is contributing the technology to the pouch-to-pouch concept.

Reifenhäuser Group
Spicher Str. 46, 53844 Troisdorf, Germany
www.reifenhauer.com

EXTRUSION

EXPERT MAGAZINE ON PLASTICS EXTRUSION

The only technical magazine worldwide exclusively for the sectors:

- Material Preparation
- Compounding
- Extrusion
- Recycling
- Calendering
- Thermoforming
- Welding
- Finishing of Plastics and Elastomers



Extrusion (German)

Extrusion International (English)

Extrusion International USA (English)

Extrusion Russia Edition (Russian)

Extrusion Asia Edition (Mandarin/English)

The only plastics trade magazine for Asia, published from Germany

8 issues a year

6 issues a year

6 issues a year

4 issues a year

2 issues a year

**SMART
EXTRUSION**

All editions available for free:

www.smart-extrusion.com

VM Verlag GmbH Cologne/Germany



CPS+ eMarketplace

NEW

International B2B online sourcing & business matching platform specialized for procurement of plastics & rubber raw materials, machinery & equipment, semi-finished & finished products, customized solutions & services



ALL IN ONE
-
ALL YEAR ROUND

Interconnect

with 4,000+ global suppliers, get to know
7,000+ products anytime, anywhere

Interactive

functions to link up with suppliers:
free submission of purchasing &
quotation requests, live chat

Precise

supplier recommendations by
professional team

Powered by CHINAPLAS

CPS+ eMarketplace is supported by
world's leading plastics and rubber
exhibition with over 35 years of expertise

**SUBMIT YOUR
SOURCING REQUESTS FOR
BEST MATCHING NOW!**

